

# 800 / 800-AL Series

## LED Architectural Recessed or Surface Wall / Ceiling Mount

Type:

Catalog Number:

Project/Location:

Approved By:

### SPECIFICATIONS

**Housing:** Heavy-duty construction of corrosion resistant die cast aluminum. Provided with (1) 3/4" KO. Decorative die-cast aluminum frames. Please see page 2 for multiple face plate options. All external hardware shall be stainless steel.

**Gasket:** Closed cell silicone foam gasket. Seals out moisture, dust, and insects for weather-tight operation.

**Mounting:** Recessed or optional surface wall/ceiling.

**Lens:** One piece molded white opal, impact resistant 1/8" thick UV stabilized polycarbonate lens.

**Driver:** Constant current and Universal input voltage 120-277V, 50-60Hz line voltage frequency. Operating temperature -20°C to 40°C, Power Factor  $\geq .90$ .

**LED:** Specify amber (A), blue (B), green (G), red (R), or 3000 (30K), 3500 (35K), 4000 (40K), and 5000 (50K) – 40K standard.

**Lumens:** 1530.

**Finish/Colors:** Zinc based primer with polyester powder coat finish in Matte Black (MB), Matte White (MW), Matt Bronze (BZ), Silver Gray (SG), or a custom color (CC).

**Testing:** LM79, LM80, ETL.

Conforms to UL Standard 1598. Suitable for wet locations.

See options page and frame options page for additional information or consult factory.



Series	Source	Wattage/Max
800	LED	21W
800-AL	LED	21W

### ORDERING EXAMPLE

800 – 1 – 21WLED – 40K – 120 – MB

800-AL – 1 – 21WLED – 40K – 120 – MB

If surface mount, 800S

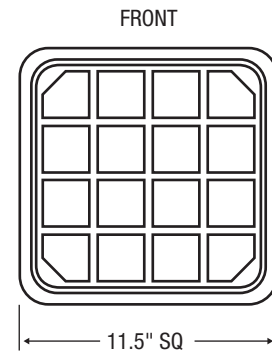

SIDE 800

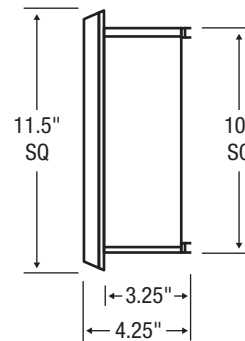

SIDE 800 with Surface Box

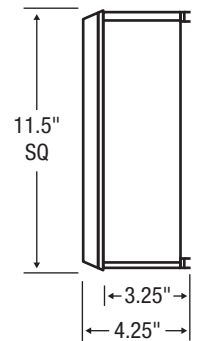

SIDE 800AL

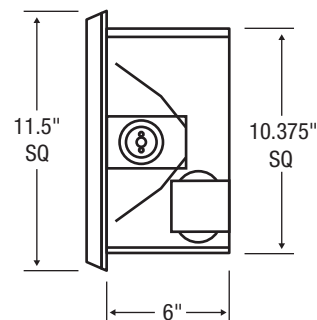

FRAME OPTIONS

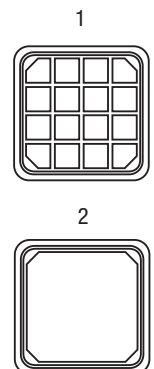

## ELCAST LIGHTING

815 S. Kay Ave., Addison, IL 60101 USA • 630.543.5390  
www.ElcastLtg.com • ElcastLtg@ElcastLtg.com

**Made in USA** – 5 year limited warranty

©2017. Specifications are subject to change without notice. Consult factory for verification.

REV 09-18