

PUMP SELECTION GUIDE

3560/1780 RPM (60Hz)

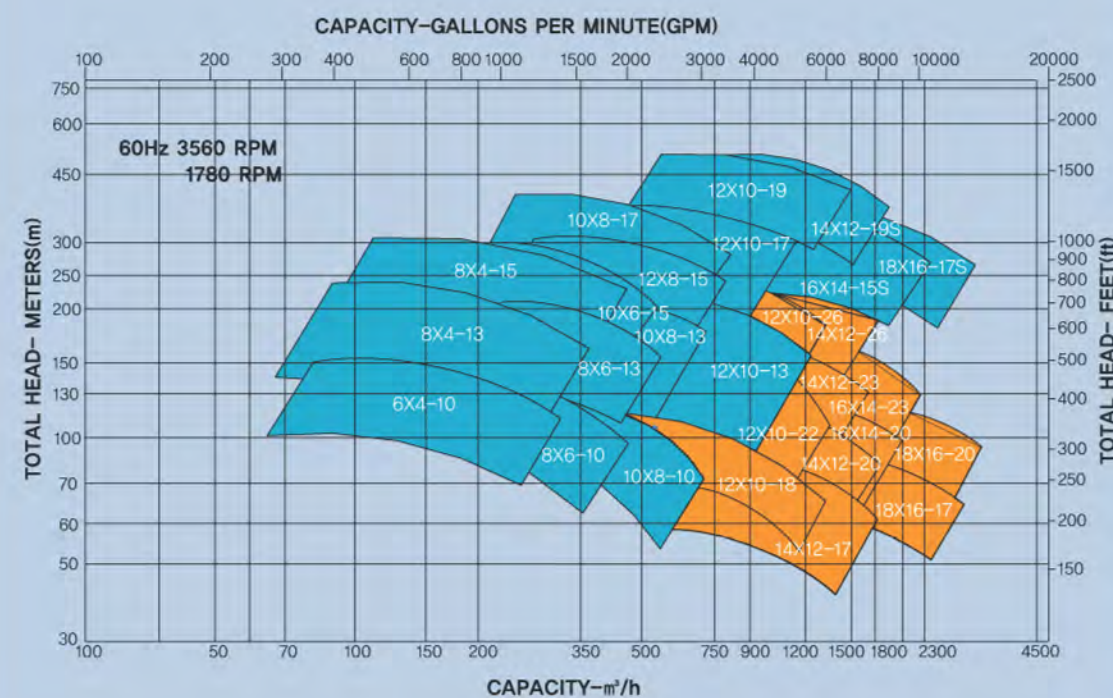

2900/1450 RPM (50Hz)

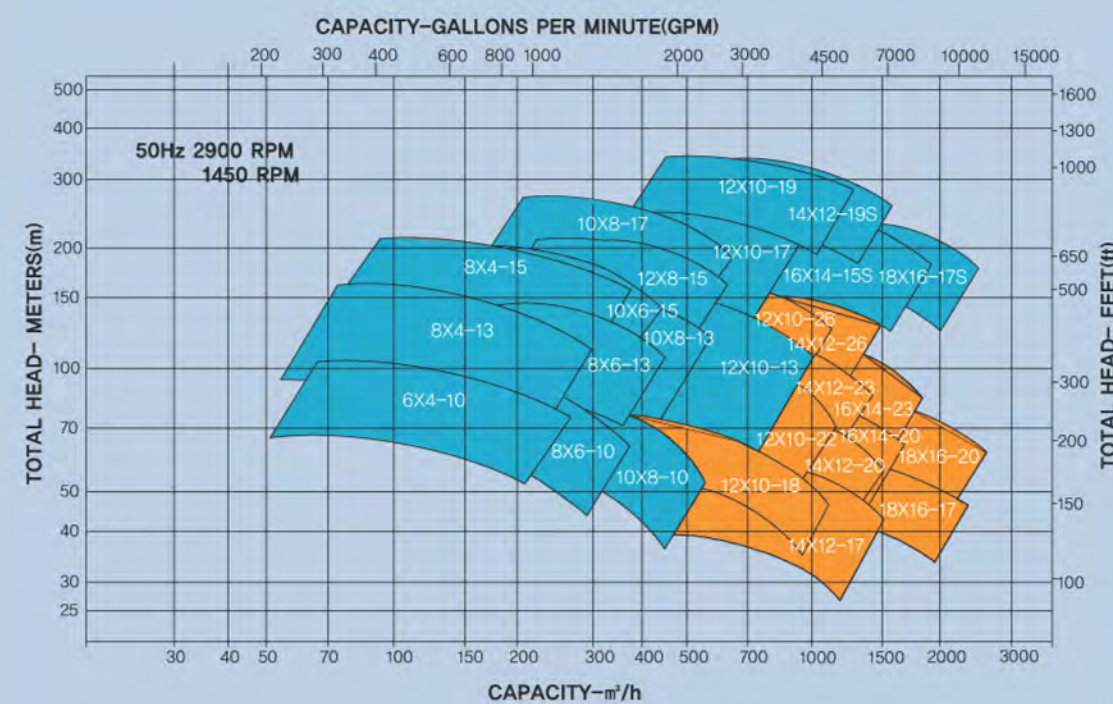

SECTIONAL

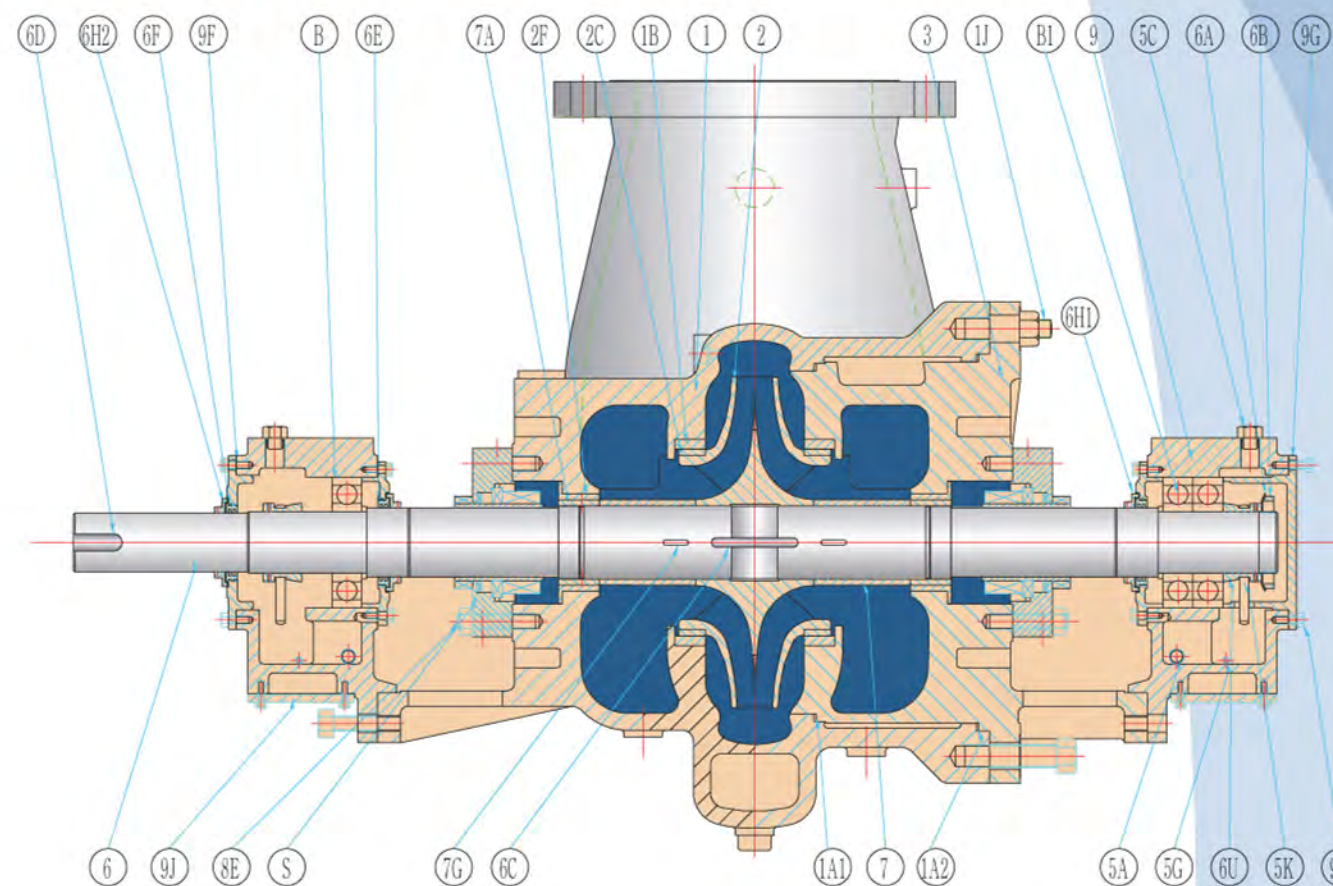

NO	PART NAME
1	CASING
1A1	GASKET(CASING-IN)
1A2	GASKET(CASING-OUT)
1B	WEARING (CASING)
1J	STUD (CASING)
2	IMPELLER
2C	WEARING (IMPELLER)
2F	THROAT BUSH
3	ENDCOVER
5A	OILER
5C	OIL CAP
5G	OIL DRAIN PLUG

NO	PART NAME
5K	OIL RING
6	SHAFT
6A	LOCK WASHER
6B	LOCK NUT
6C	IMPELLER KEY
6D	COUPLING KEY
6E	LABYRINTH SEAL-IN
6F	LABYRINTH SEAL-OUT
6H1	DEFLECTOR-IN
6H2	DEFLECTOR-OUT
6U	RELEASE COOLER
7	SLEEVE

NO	PART NAME
7A	SLEEVE NUT
7G	SLEEVE KEY
8E	STUD (SEALCOVER)
9	BEARING HOUSING
9A	HEXBOLT
9F	BEARING COVER-OPEN
9G	BEARING COVER-CLOSE
9J	JACKET(B/HOUSING)
9JA	JACKET BOLT(B/HOUSING)
9JB	GASKET (BH-JACKET)
B1	BEARING OUT
B	BEARING
S	MECHANICAL SEAL

Truflo Pumps, Inc.

7105 Cessna Drive
Greensboro, NC 27409

Ph: (336) 664-9225
Fax: (336) 664-1353

E-Mail: Sales@TRUFLO.com
Website: www.TRUFLO.com

API 610, 11th Ed. Single Stage Double Suction Pump (BB2)

TDP Series



API 610, 11th Ed. Single Stage Double Suction Pump (BB2)



TDP SERIES

API 610, 11th Ed. Single Stage Double Suction Pump (BB2)

- Max.Capacity : 8000m³/h (35200GPM)
- Max.Head : 340m (1120ft)
- Temperature : 400°C (13520°F)
- Allowed Pressure : 60kg/cm² (850psi)
- Power : 2500kw (3350HP)
- Material : DCI, WCB, CF8, CF8M, CD4M, CN7M, HASTELLOY B&C, CA6NM, CF3M
- Back pull-out design for easy maintenance.
- Centerline mounted for high temp service.
- Between bearings design for improving rotor stability.

Truflo pumps is providing pumping solutions allowing its customers to continuously improve productivity, profitability and pumping system reliability.

API 610(BB2) Radially Split, Double Suction Process Pump
The TRUFLO BB2 pump meets requirements of API 610, 11th Ed. (BB2)
It is engineered and built for reliable, safe performance at the elevated temperatures and pressures experienced in refining and power applications.

APPLICATION

- Petroleum refining, production and distribution
- Petrochemical and heavy-duty chemical processing
- Gas industry services
- Boiler-feed booster and other high temperature services
- Water and general industrial

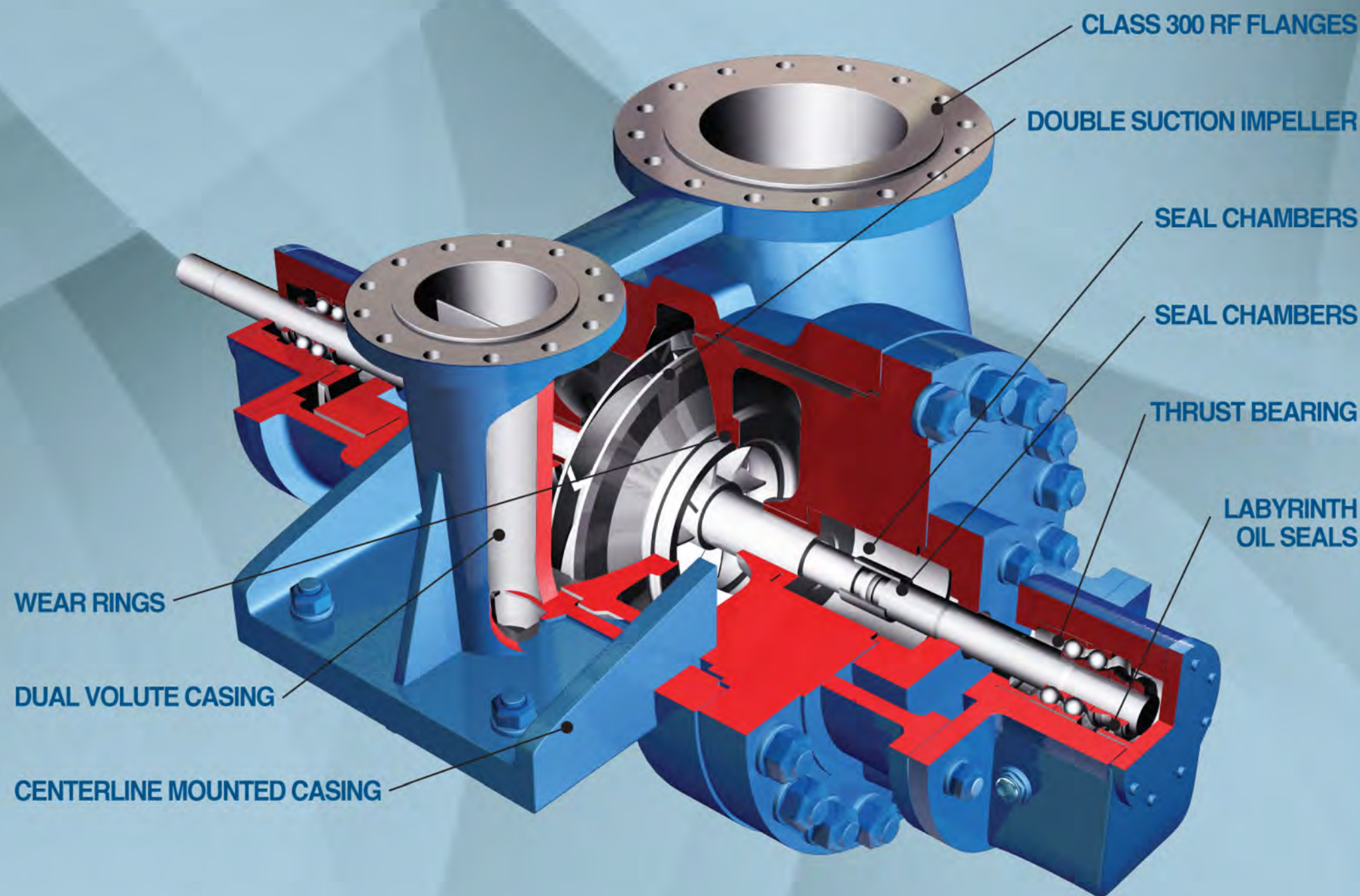

CLASS 300 RF FLANGES STANDARD

Other classes and facings optional.

HEAVY DUTY SHAFT

Minimum shaft deflection for extended seal and bearing life. Sized to meet requirements of API610.

RENEWABLE WEAR RINGS

API 610 clearances. Positively locked. Standard feature.

CENTERLINE MOUNTED CASING

Heavy duty mounting extensions accept API 610 nozzle loads and maintain pump alignment under extreme service conditions.

DOUBLE SUCTION IMPELLER

Designed for low NPSH services. Hydraulically designed to balance axial loads for increased bearing life.

DUAL VOLUTE CASING

Evenly balances radial forces for minimum shaft deflection, increased bearing, and seal life.

RADIALLY SPLIT CASING

Designed specifically for high pressure/ high temperature services. Fully confined controlled compression gasket assures leak-proof sealing.

ENLARGED SEAL CHAMBERS

Conform to API 610 dimensional requirements. Allows use of wide range of API 682(ISO 21049) cartridge mechanical seals to meet specific service conditions.

CASING HEAD ON OUTBOARD END

Allows removal of rotor without disturbing driver or suction and discharge piping.

HEAVY DUTY THRUST BEARING

Duplex 40° angular contact thrust bearings and deep-groove radial bearings.

LABYRINTH OIL SEALS

Labyrinth seal design prevents oil from leaking out and contaminants from intruding. Made from non-sparking metal.

API 610, 11th Ed.

Single Stage Double Suction Pump (BB2)