



**ASHBURN
VAULT COMPANY, Inc.**
18 Washburn Way
Hinsdale, NH 03451

Precast Concrete • Redi Mix

NOTES:

- *Reinforcing Steel Deformed bars conform to latest ASTM specification A615.
- * Concrete compressive strength 4000 PSI at 28 days.
- *Method of manufacture: Wet Cast
- *Section is Monolithic
- *Cracking may occur due to excessive heat
- *Galvanized inner and outer rings on steel fire pit
- *Steel liner for fire pit

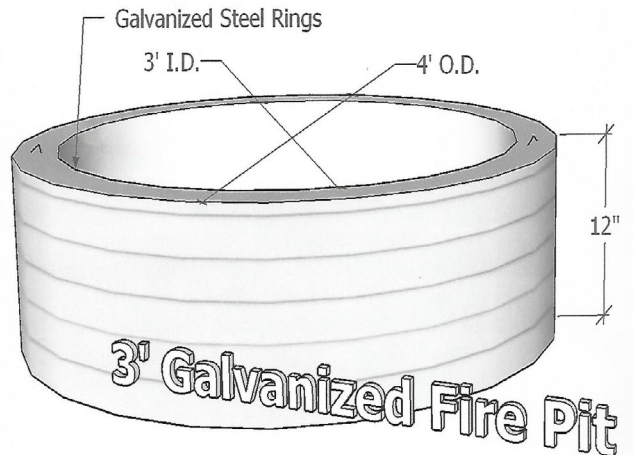
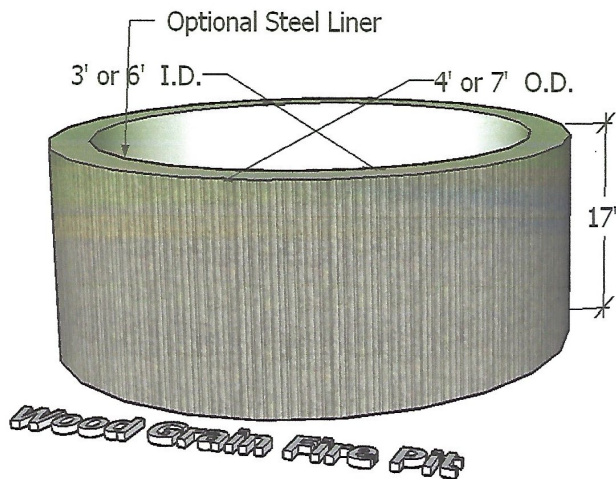
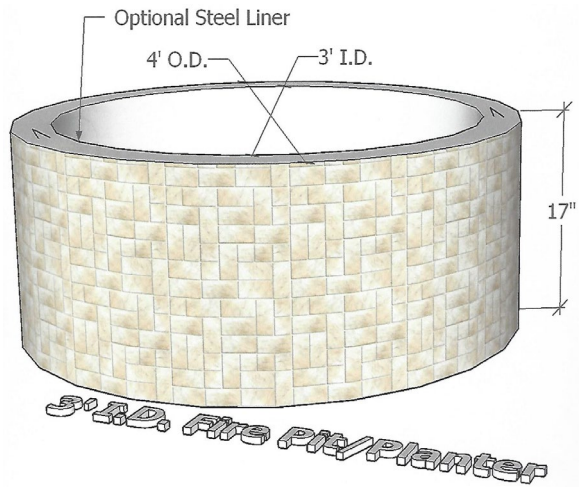
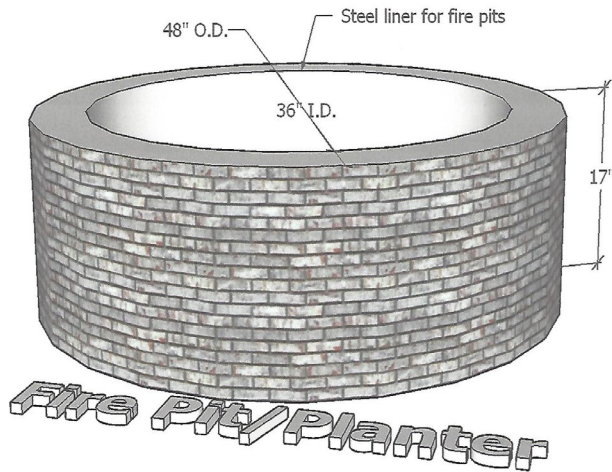

FIRE PIT / PLANTER

Phone: 603-256-6891

E-MAIL: WASHBURNVAULT@YAHOO.COM

DATE: 1/1/2017

WEIGHT: 1,000 LBS