

# Assembly Instructions

8

## Preparations for assembly

Check that ducts and fittings to be used in the system are EHG G-3 and are undamaged. All EHG G-3 fittings must be used with calibrated spiral duct certified by EHG.

Do not use ducts or fittings that have been damaged in such a way that they jeopardize the air tightness or structural strength of the system.

Store ducts and fittings in a well-ordered and weatherproof storage area to minimize the risk of damage.

Cut ducts at right angles. Carefully remove any burrs from cut edges. Installation is easier and the risk of damaging the gasket is reduced if there are no burrs.

## Assembly

Start by inserting the turned-over edge of the fitting into the duct.

Check that the first lip of the gasket is in contact with the edge of the duct all the way around and sticks straight out so that the lip is not twisted in one direction or the other.

Push the end of the fitting into the duct. Turning the fitting slightly aids insertion. (Removal, if necessary, is also aided by turning.)

Secure the fitting in the duct using self-tapping screws or airtight pop rivets.

Fasteners should be positioned 1/2" from the bead to prevent damage to the gasket.

Placement of the fastening screws should be opposite from one another evenly spaced around the circumference, much like the procedure for tightening lug nuts on a tire (see diagram). Start where the distance between the duct and the fitting is largest. Screws should be placed approximately 1/2" from the bead in order to avoid damaging the EHG G-3 gasket. In the event of incorrect installation, holes caused by screws or pop rivets must be sealed before reassembly.

Quantities and sizes to be used are listed in the below table.

Duct Dia. (inch)	Screw Dia. (inch)	Quantity
3 - 5	1/8	2
6 - 10	1/8	3
12 - 24	1/8	4
26 - 50	1/8	6
52 - 60	1/8	8

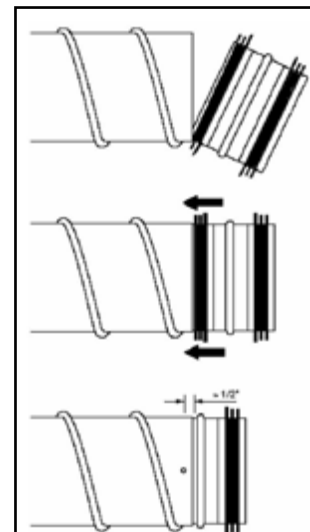
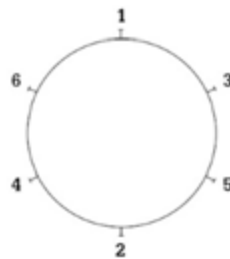

Always start the first fastener at the largest radial gap between fitting and duct. Be sure to achieve even distribution around the circumference.

Carefully seal any holes left by measurements, removed screws, pop rivets, etc.