

CLINTON'S MODEL 199 UNDERBED TRIMMER FOR UNION SPECIAL 63900

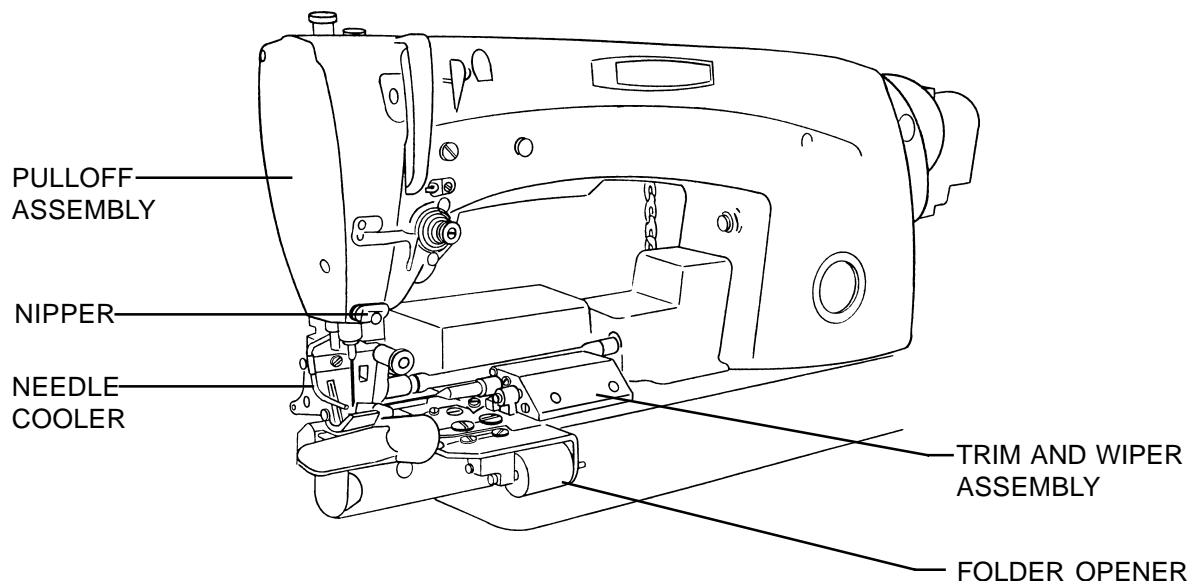

SERVICE MANUAL

40-0252-01

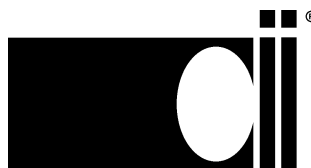

Clinton Industries, Inc.
700 Washington Ave.
Carlstadt, N.J. 07072
Phone: 201-935-4242
Fax: 201-935-3615
Web Site: <http://www.clintonind.com>
Email: general@clintonind.com

TABLE OF CONTENTS**THREAD TRIMMER SECTION**

SECTION	I	GENERAL INFORMATION	1
		A. INTRODUCTION	1
		B. APPLICATION	1
		C. TRIMMER COMPONENTS	1
SECTION	II	TRIMMER INSTALLATION	2
		A. PULLOFF ASSEMBLY	2
		B. TENSION RELEASE AND PULLOFF ASSEMBLY. .	2
		C. CUTTER AND WIPER ASSEMBLY	2
		D. SOLENOID AIR VALVE CONTROL UNIT.	2
		E. NEEDLE COOLER	2
		F. FOLDER OPENER	2
SECTION	III	PRELIMINARY SETTINGS	3
SECTION	IV	TRIMMER ADJUSTMENTS	3
		A. TENSION RELEASE AND PULLOFF ASSEMBLY . .	3
		B. CUTTER AND WIPER ASSEMBLY	3
		C. SOLENOID AIR VALVE CONTROL UNIT	3
		D. FOOTLIFTER ASSEMBLY	3
		E. NEEDLE COOLER	4
		F. FOLDER THREAD WIPER	4
SECTION	V	TRIMMER SEQUENCE OF OPERATION	4
		A. UNDERBED TRIMMER	4
		B. TENSION RELEASE	4
		C. NEEDLE THREAD WIPER	4
SECTION	VI	TROUBLE SHOOTING	5
SECTION	VII	PARTS DRAWINGS	6-12

I. GENERAL INFORMATION

A. INTRODUCTION

The air Operated Underbed Trimmer contains a trimming system that cuts both the needle and bobbin threads simultaneously. A movable and a stationary blade, mounted on the throat plate are used in combination to pick up and cut the threads.

Solid state electronics are used to sense the position of the needle and to trigger the trimming mechanism at the proper time as well as to control footlifting and backtacking operations.

B. APPLICATION

The underbed Trimmer/Positioner enables the operator to automatically control the position of the needle in or out of the work, thereby eliminating the need for hand positioning. In addition, the top and bottom threads are automatically cut beneath the throat plate after positioning. This eliminates the need for hand trimming.

C. SYSTEM COMPONENTS

The trimmer components, which can be either pre-installed on the sewing machine head and factory tested, or field installed, include:

1. Standard Components
 - a. Pulloff Assembly
 - b. Tension Release and Pulloff Assembly
 - c. Thread Cutter and Wiper Air Cylinder Assembly
 - d. Solenoid Air Valve Control Unit
2. Optional Components
 - e. Foot Lifter
 - f. Needle Cooler
 - g. Folder Opener

D. TUBING

1/8" O.D. X 1/16" I.D.

MATERIAL VINYL

30-1134-01 CLEAR
-02 YELLOW
-03 RED
-04 BLACK
-05 BLUE
-06 GREEN
-07 ORANGE
-08 WHITE
-09 GRAY
-10 BROWN

3/16" O.D. X 3/32" I.D.

MATERIAL POLYURETHANE

30-1540-01 CLEAR
-02 YELLOW
-03 RED
-04 BLACK
-05 BLUE
-06 GREEN
-07 ORANGE
-08 WHITE
-09 GRAY
-10 BROWN

1/4" O.D. X 1/8" I.D.

MATERIAL POLYURETHANE

30-2102-01 CLEAR
-03 RED

II. TRIMMER INSTALLATION

A. PULLOFF ASSEMBLY

Remove the machine face plate and mount the Pulloff assembly as shown in INS-2377.

B. TENSION RELEASE AND PULLOFF ASSEMBLY

1. Remove from the machine the thread tension discs assembly and tension release pin.
2. Drill and Tap mounting holes using appropriate drill fixture supplied. Refer to machine drilling instructions shown in drawing INS-2355.
3. Mount tension release assembly and the thread tension discs assembly to the sewing machine as shown in drawing INS-2353.

C. CUTTER AND WIPER ASSEMBLY

1. Remove from the machine throat plate and feed shaft clamp plate.
2. Rework clamp plate as shown in drawing INS-1630 and fasten to the machine.
3. Fasten cutter and wiper cylinder assembly to sewing machine bed.
4. Mount new throat plate assembly on the machine with original hook basket retaining finger.

D. SOLENOID AIR VALVE CONTROL UNIT

1. Mount solenoid valve assembly in back of the machine bed as shown in INS-2379.
2. Mount foot lifter air cylinder assembly as shown in INS-2379.

E. NEEDLE COOLER

1. Fasten needle cooler tube to presser foot and roller housing bracket.
2. Mount treadle air valve assembly supplied between the motor and treadle arm.

F. FOLDER OPENER

1. Mount folder opener air cylinder assembly on bed of machine.
2. Assemble the folder opener assembly to the machine cylinder arm.

III. PRELIMINARY SETTINGS

NOTE: Do not connect the air supply at this time.

1. Set the machine head in the table and install "V" belt.
2. Time sewing machine to normal sewing conditions.
3. Connect all air lines as shown in circuit diagram drawing INS-2339.
4. Connect all electrical cables to the main control box.
5. Thread the sewing machine and sew on material being used on the operation.

IV. TRIMMER ADJUSTMENTS

A. TENSION RELEASE

Adjust puller for sufficient thread tail left on needle to start sewing on the next cycle.

B. CUTTER AND WIPER ASSEMBLY

1. Loosen the 10-32 nut on the cylinder shaft and adjust the knife travel so that the cutting edge is about 1/16" past the cutting edge of the stationary blade.
2. Adjust the wiper to pass between the needle and the presser foot without striking either. By loosening the two nuts on the cylinder shaft, the assembly will rotate around the screw to position the wire hook. Bending may be necessary for proper thread pickup.
3. With the power and air off, manually stimulate the trimmer sequence of operation cycle several times to insure that the proper adjustments have been made.

C. SOLENOID AIR VALVE CONTROL UNIT

Turn power and air on. Set regulator to read 60 PSI and adjust the flow control of the trim air cylinder to reduce bobbin spin.

D. FOOTLIFTER ASSEMBLY

Adjust footlifter cylinder for required amount of lift. Readjustment of footlift linkage may be necessary.

E. NEEDLE COOLER

Adjust the flow control for the desired air flow to cool the needle and keep the throat plate knife clean.

F. FOLDER OPENER

Adjust folder opener mounting bracket for required amount of opening.

V. **TRIMMER SEQUENCE OF OPERATION**

A. UNDERBED TRIMMER

The operation of the underbed trimmer is as follows:

1. Needle positioner stops with the needle thread positioned between the 5 and 6 o'clock position across the hook. The needle is used for the reference point or 12 o'clock position.
2. The movable knife is extended into the needle loop and in position to pick up the bobbin thread.
3. The needle positioner moves the takeup and needle to up position.
4. The tension release, the pulloff and wiper cylinders operate after the positioner reaches to up position.
5. Then the movable knife is returned to cut both needle and bobbin threads.

B. TENSION RELEASE

The needle thread tension is released so that the thread puller can pull off enough thread to start the next sewing operation.

C. NEEDLE THREAD WIPER

The needle thread wiper pulls the needle thread above the foot before it is raised. If the thread is trapped under the foot a long tail will be left at the start of the next sewing operation.

VI. TROUBLESHOOTING

PROBLEM	PROBABLE CAUSE	CORRECTIVE ACTION
Needle thread not cut. Bobbin thread is cut	Positioner solenoid binding	Remove bind
	Movable blade missed needle loop	Check synchronizer timing to see that trimmer is fired at correct time
	Binds in trimmer linkage	Locate and remove bind. A light bind would slow it enough to miss needle loop
Both threads not cut not picked up	Defective movable blade	Replace
	Water in air lines	Check filter. Remove water from air lines
	Defective solenoid air valve or air cylinder	Repair or replace
	Defective needle positioner logic	Repair logic
Both threads picked up not cut	Binds in trimmer linkage	Locate and remove bind
	Defective movable or stationary blade	Replace
Needle thread cut short	Stroke misadjusted failing to reach cutting position	Readjust
	Pulloff cylinder improperly adjusted	Readjust
Long tail left on top side at start of sewing	Wiper not operating or incorrectly positioned causing thread to be trapped under foot	Repair or reposition thread wiper as required
Bobbin thread is cut short	Bobbin tension too tight	Loosen bobbin tension as much as possible
	Bobbin thread slipped out of hook on case	Run bobbin thread through hook
	Bobbin case without hook being used	Replace with correct bobbin case

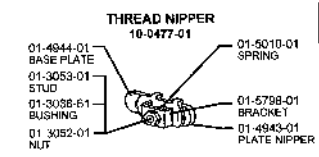

PULLOFF ASSEMBLY
MODEL 199 U.S. 63900
80-0503-01

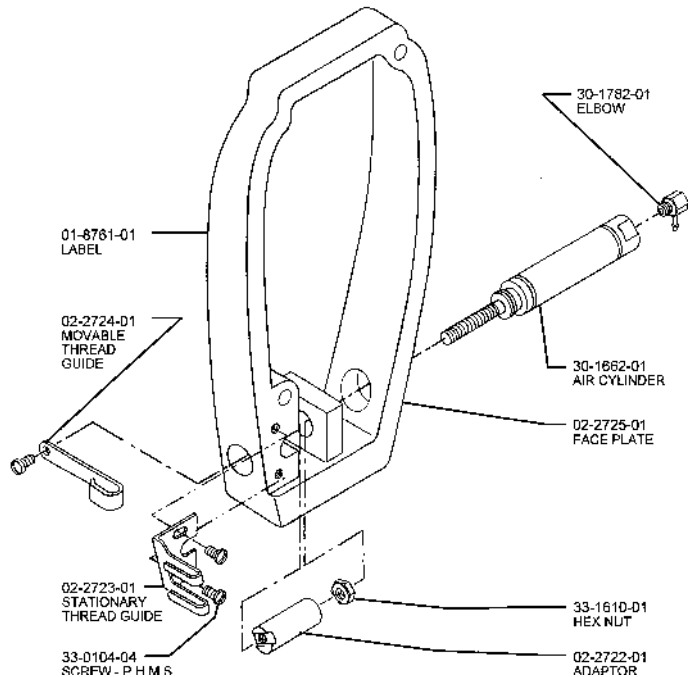

TRIM AND WIPER ASSEMBLY
MODEL 199 FOR U.S. 63900
80-0514-01

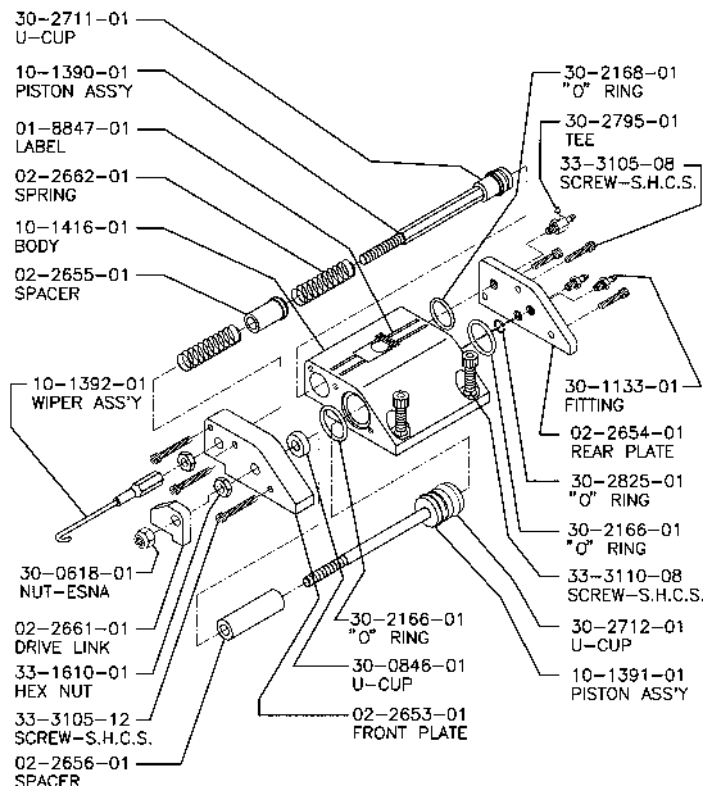

TENSION RELEASE ASSEMBLY
MODEL 199 U.S. 63900
80-0517-01

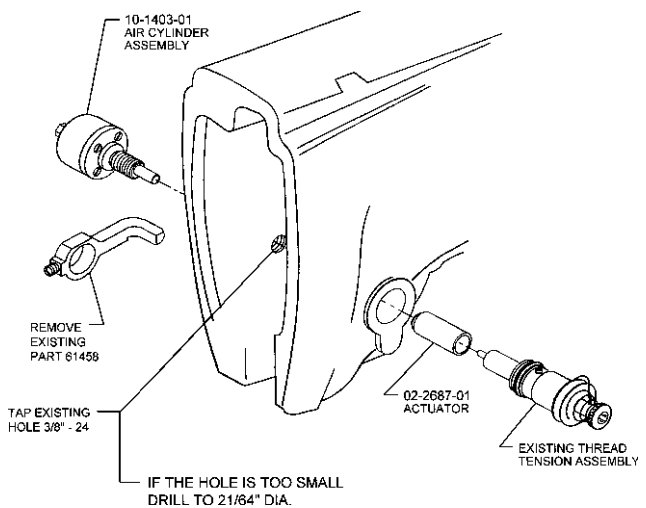

AIR CYLINDER THREAD RELEASE ASSEMBLY
MODEL 199 U.S. 63900
10-1403-01

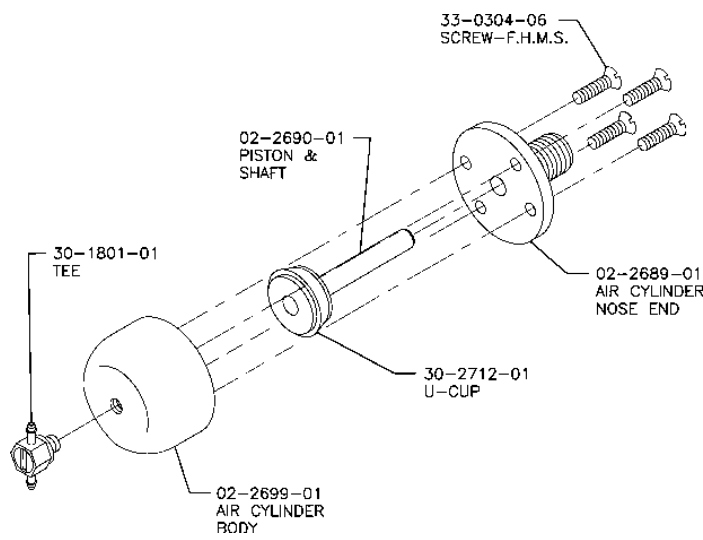

**DRILLING INSTRUCTIONS / DRILL FIXTURE KIT
MODEL 199 FOR U.S. 63900
10-1405-01**

ML199-12
INS-2355A

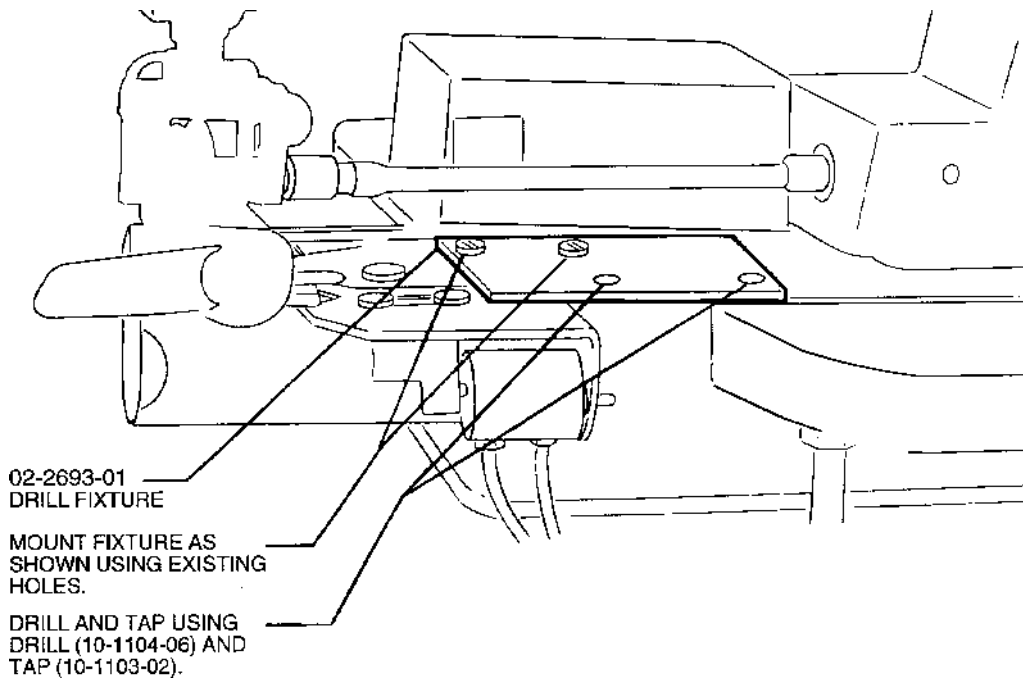

**DRILLING AND MOUNTING INSTRUCTIONS
THREAD NIPPER ASSEMBLY 61400 M, T, W - 63900 M, T, W
REWORK - TAKEUP SPRING THREAD WIRE 61400 M, T, W**

INS-765B

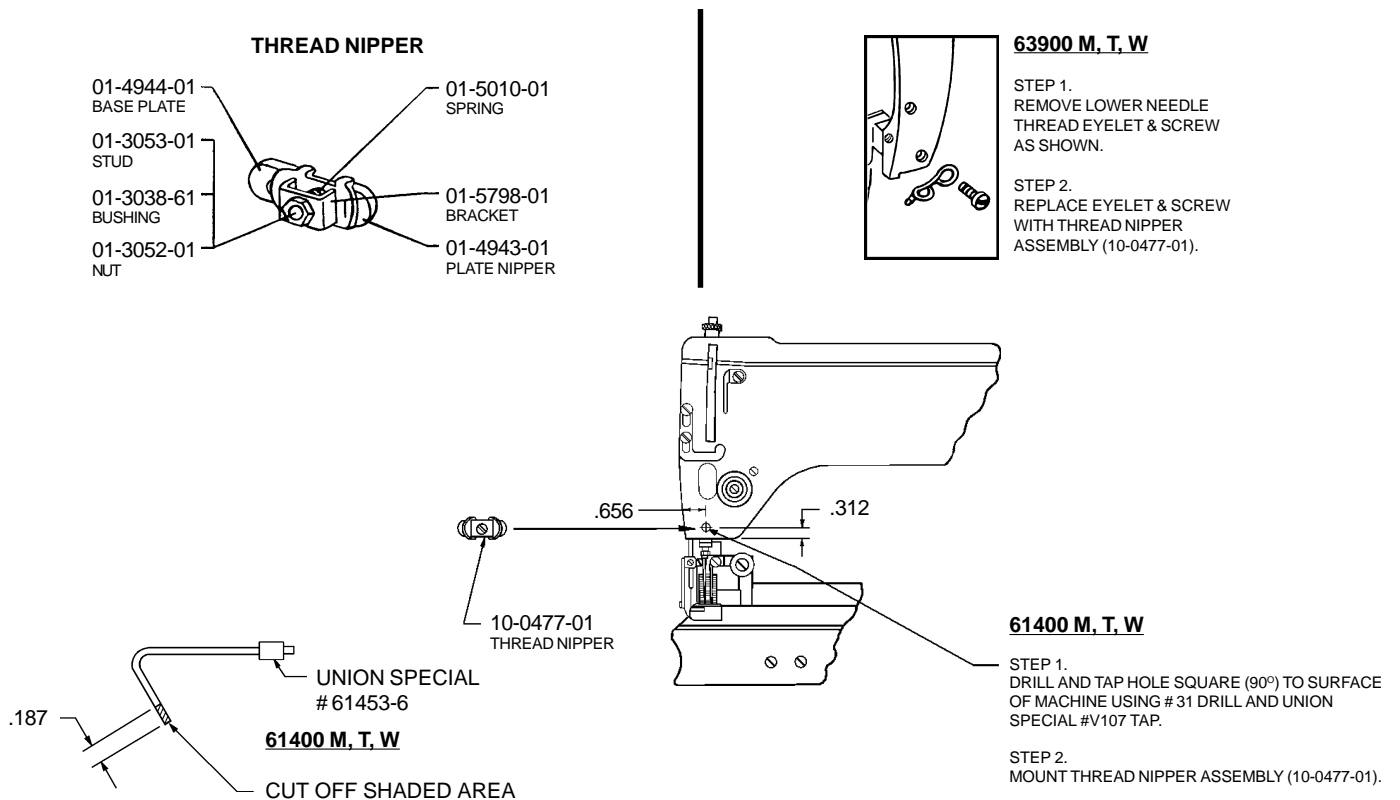

**FOLDER ASSEMBLY
MODEL 199 FOR U.S. 63900
80-0513-01**

INS-2335B

NOTE:
ALL PARTS NOT IDENTIFIED ARE
SUPPLIED BY UNION SPECIAL.
SEE UNION SPECIAL MANUAL.

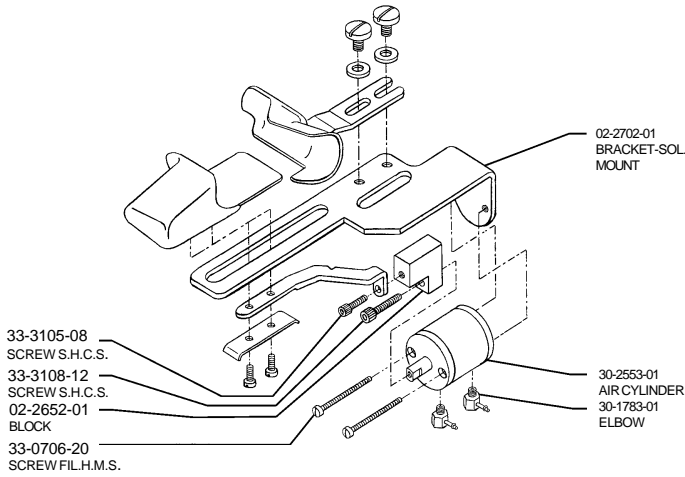

**ACCUSTOP
SYNCHRONIZER ADAPTER MOUNTING FOR U.S. 63900
80-0323-51**

INS-1667C

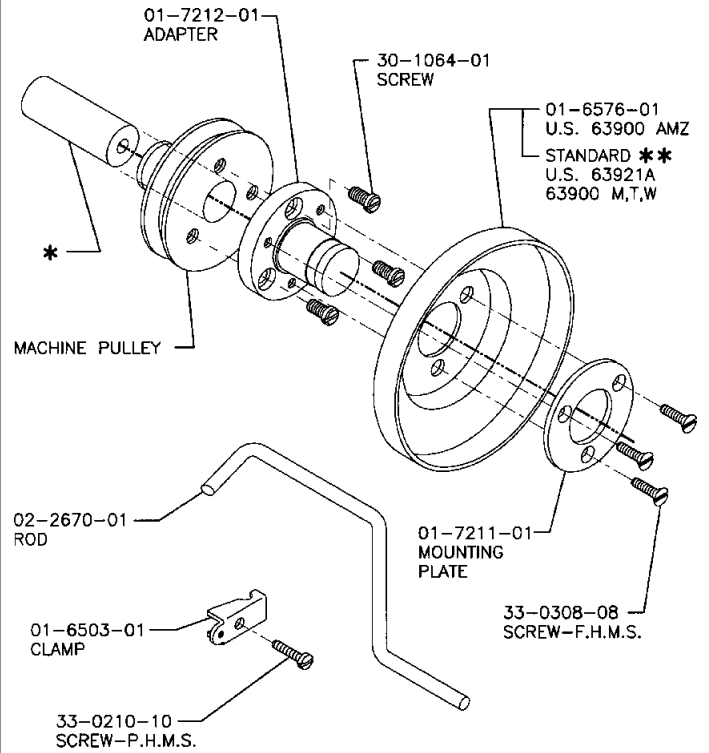

* FOR ALIGNMENT INSERT
ARBOR 02-2703-01 AND
TIGHTEN SCREWS 01-3070-01.

** NOT PART OF
ASSEMBLY

INS-1630-1

REWORK FEED SHAFT CLAMP PLATE

CHAMFER THIS
CORNER APPROX.
AS SHOWN

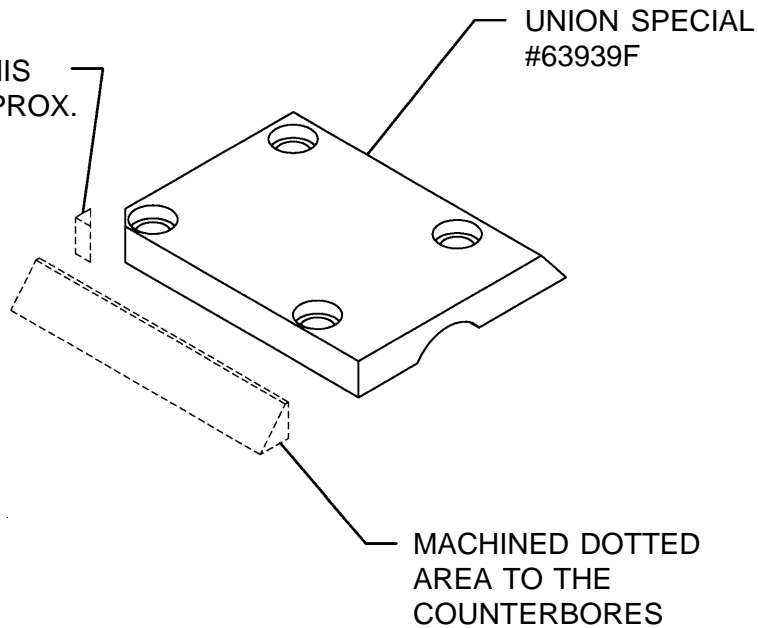

INS-2339D

AIR DIAGRAM
DIAGRAMA DEL CIRCUITO DE AIRE
 MODEL 199, UNION SPECIAL 63900

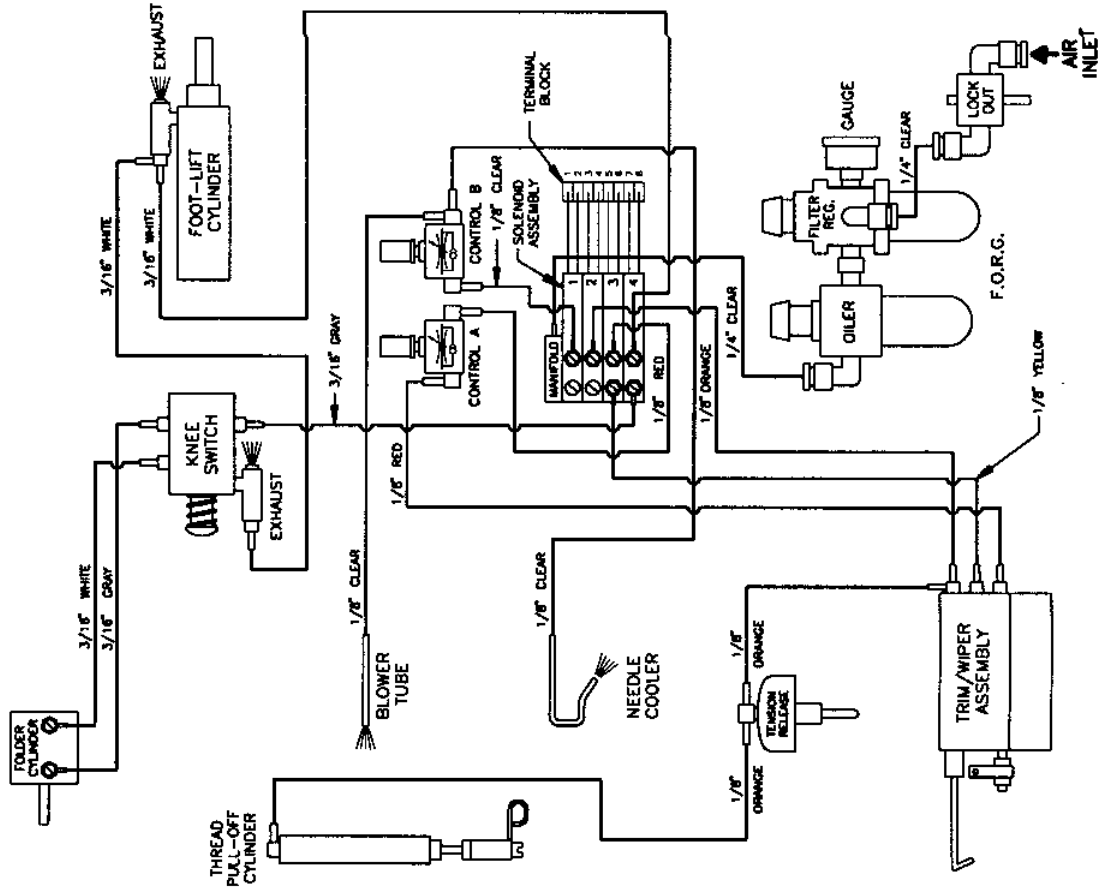

INS-2340H

SOLENOID VALVE ASSEMBLY
VALVULA SOLENOIDE
 MODEL 199 FOR U.S.63900
 ASSEMBLY NO. 81-0824-01

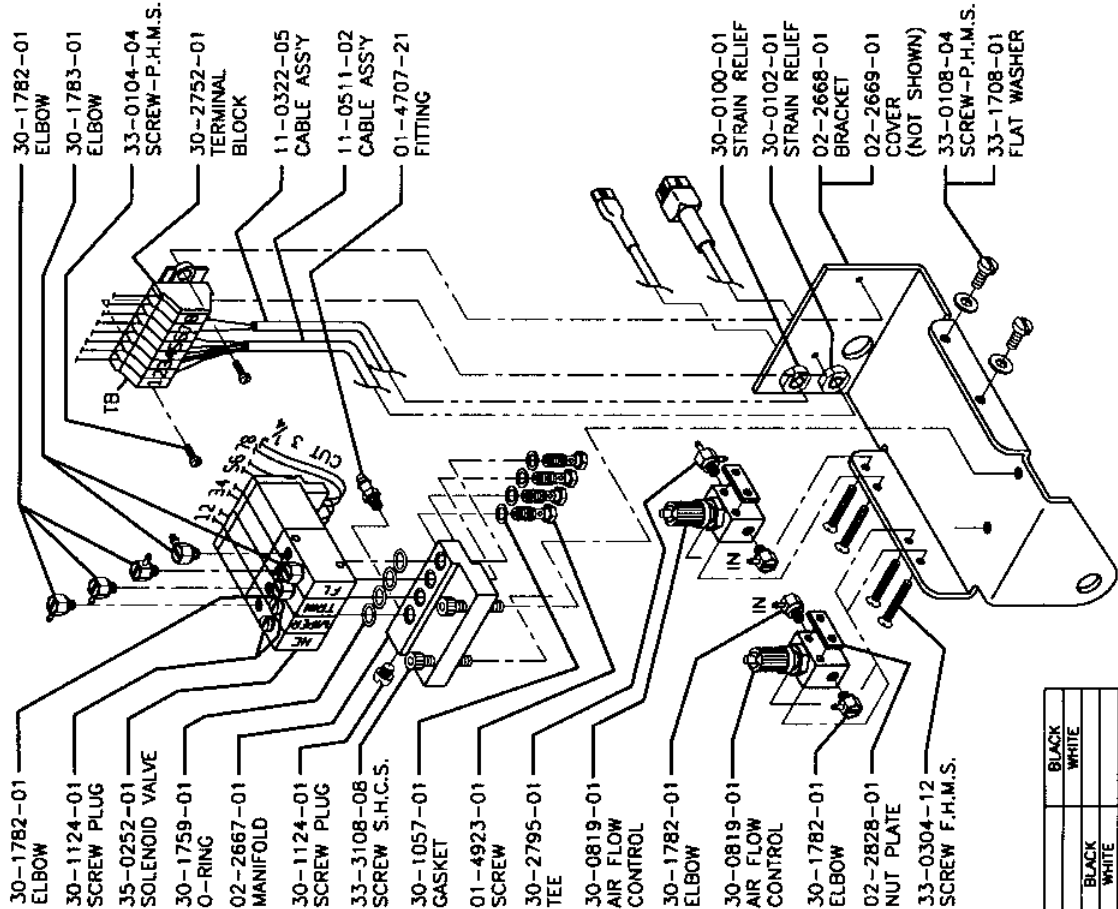

- 30-1782-01 ELBOW
- 30-1124-01 SCREW PLUG
- 35-0252-01 SOLENOID VALVE
- 30-1759-01 O-RING
- 02-2667-01 MANIFOLD
- 30-1124-01 SCREW PLUG
- 33-3108-08 SCREW S.H.C.S.
- 30-1057-01 GASKET
- 01-4923-01 SCREW
- 30-2795-01 TEE
- 30-0819-01 AIR FLOW CONTROL
- 30-1782-01 ELBOW
- 30-0819-01 AIR FLOW CONTROL
- 30-1782-01 ELBOW
- 02-2828-01 NUT PLATE
- 33-0304-12 SCREW F.H.M.S.
- 30-1782-01 ELBOW
- 30-1783-01 ELBOW
- 33-0104-04 SCREW-P.H.M.S.
- 30-2752-01 TERMINAL BLOCK
- 11-0322-05 CABLE ASSY
- 11-0511-02 CABLE ASSY
- 01-4707-21 FITTING
- 30-0100-01 STRAIN RELIEF
- 30-0102-01 STRAIN RELIEF
- 02-2668-01 BRACKET
- 02-2669-01 COVER (NOT SHOWN)
- 33-0108-04 SCREW-P.H.M.S.
- 33-1708-01 FLAT WASHER

8	7	6	5	4	3	2	1	11-0511-02 11-0322-05	TB
									COLOR
			BLACK						
			WHITE						
			ORANGE						
			BLUE						
			RED						
			GREEN						

INS-2338C

FILTER, REGULATOR & GAUGE ASSEMBLY
FILTRO, REGULADOR Y MEDIDOR DE PRESION
 MODEL 199, FOR U.S. 63900
 80-0181-25

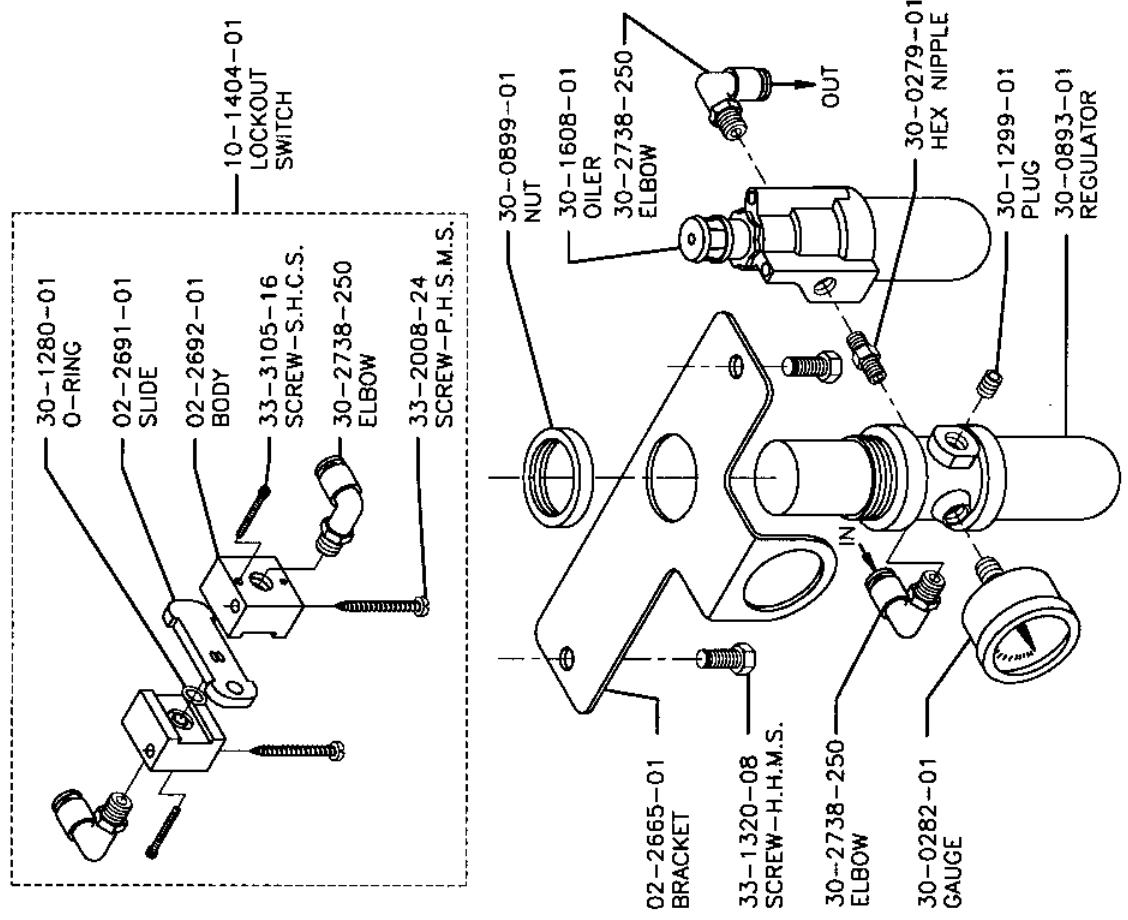

INS-598-8A

AIR VALVE ASSEMBLY
VALVULA DEL AIRE
 MODEL 199
 80-0187-13

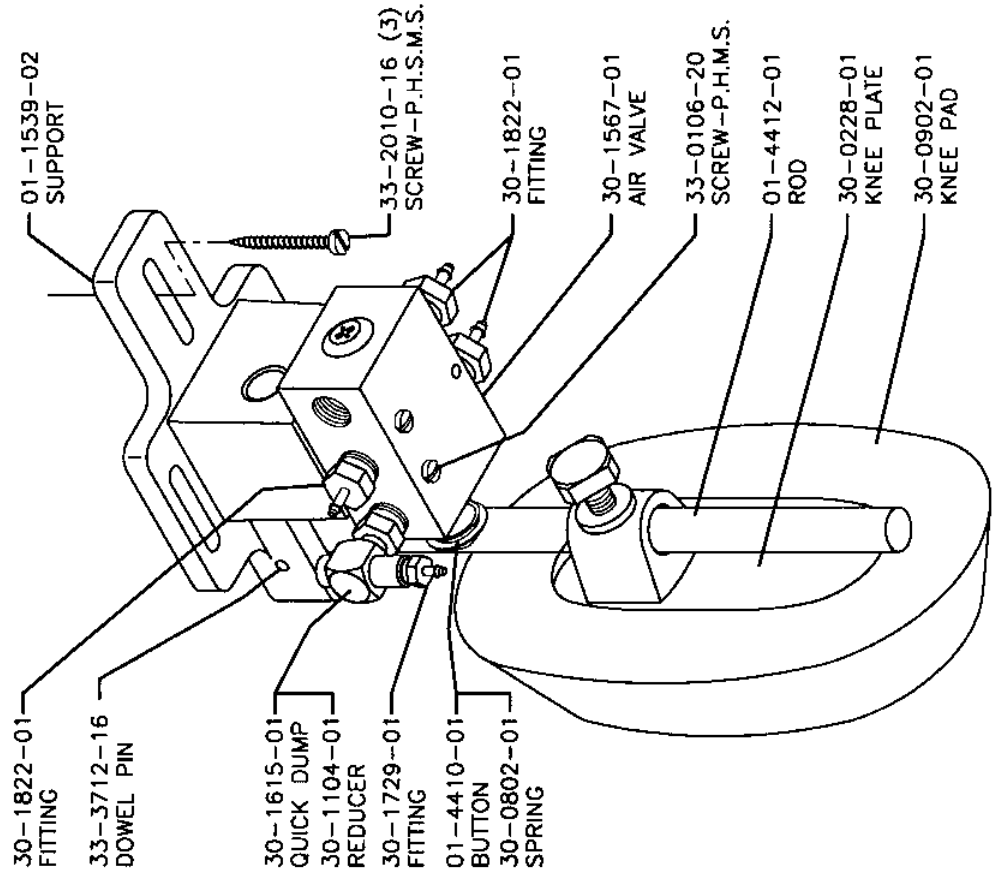

NEEDLE COOLER ASSEMBLY
80-0204-03

01-4936-01
TUBE

01-4938-01
CLAMP

30-1064-01
SCREW

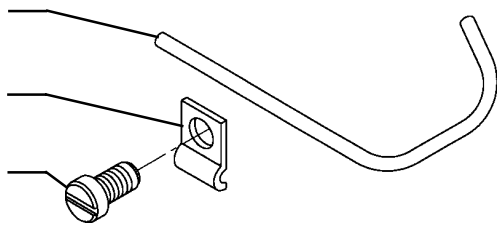

MODEL 199
(MACHINE REAR VIEW)

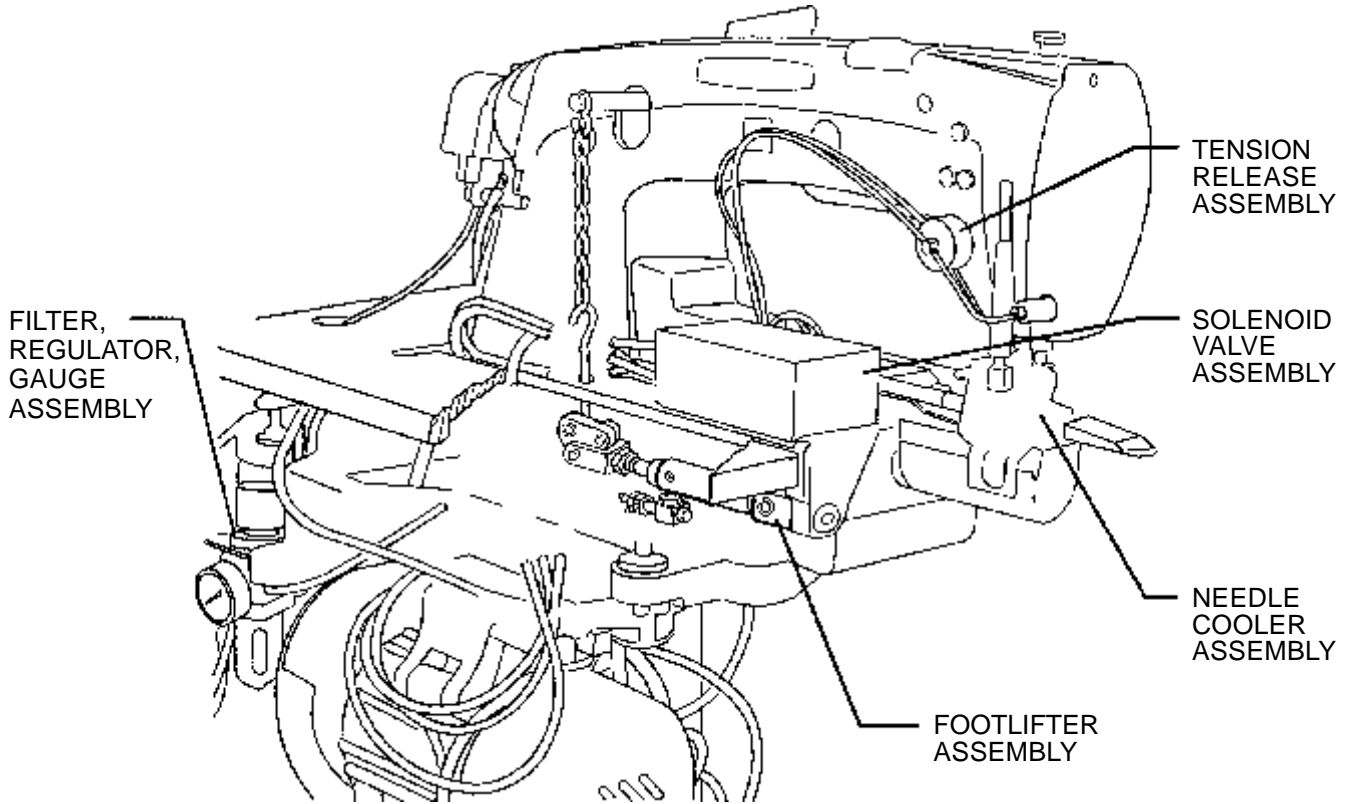

THROAT PLATE ASSEMBLY
MODEL 199 FOR U.S. 673900
80-0515-01

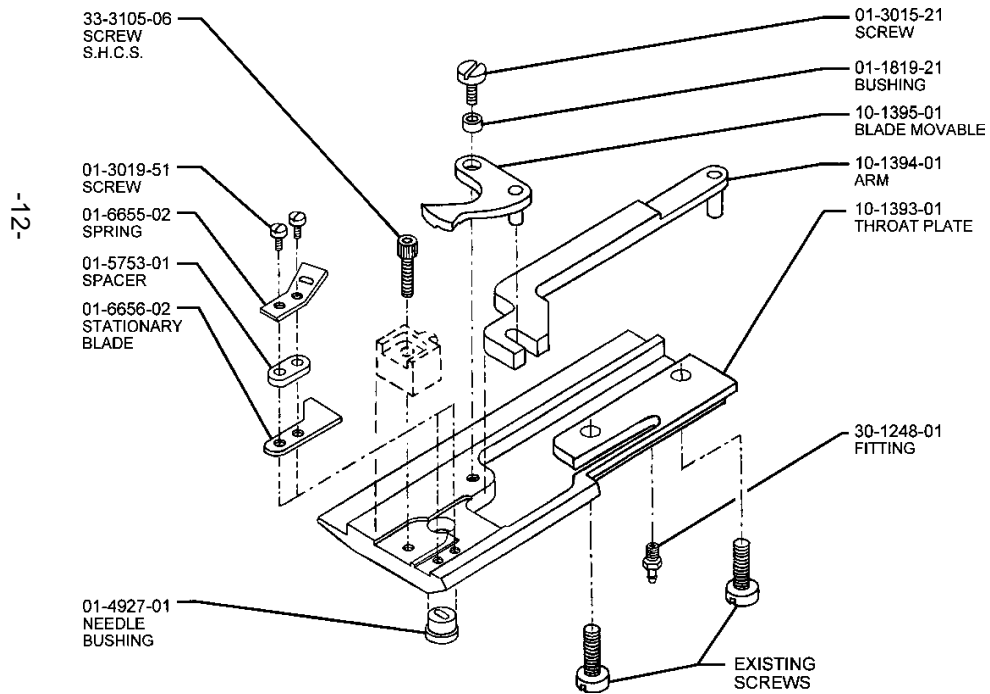

**FOOTLIFTER ASSEMBLY
MODEL 199 FOR U.S. 63900
80-0180-125**

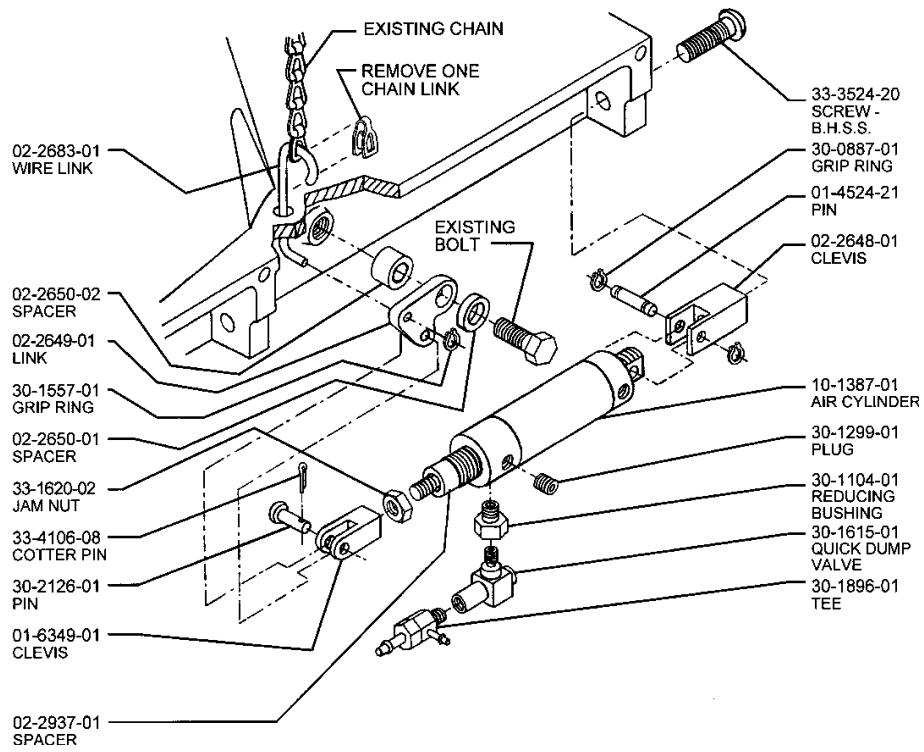

ML199-17

FILTER/REGULATOR

ML-000-5B

OPERATION

AIR ENTERS THE INTEGRAL FILTER/REGULATOR UNIT AND IS DIRECTED DOWNWARD THROUGH A SET OF LOUVERS (10) TO IMPART A WHIRLING ACTION. THIS CENTRIFUGAL ACTION CAUSES LIQUID PARTICLES TO BE SEPARATED FROM THE AIR STREAM AND SETTLE TO THE BOTTOM OF THE BOWL. ACCUMULATED LIQUID IS DRAINED MANUALLY (15).

AIR THEN PASSES THROUGH THE SINTERED BRONZE FILTER ELEMENT (11) WHERE SMALLER SIZE FOREIGN PARTICLES ARE REMOVED.

THE CLEAN AIR PASSES THROUGH THE VALVE (5,6,7,8) OF THE REGULATOR AND IS CONTROLLED TO A PRESSURE, DETERMINED BY THE ADJUSTMENT OF THE REGULATOR. PRESSURE IS INCREASED BY ROTATING THE KNOB CLOCKWISE, OR DECREASED BY ROTATING THE KNOB COUNTERCLOCKWISE.

CAUTION: THIS MINIATURE INTEGRAL FILTER/REGULATOR SHOULD NOT BE USED IN APPLICATIONS WHICH MAY EXCEED 250 PSIG. DURING MAINTENANCE PERIODS, INSPECT AND CLEAN EACH PART CAREFULLY, USING ONLY CLEAR, WARM WATER OR KEROSENE. DO NOT USE SOLVENTS AS THE POLYCARBONATE BOWL MAY BE DAMAGED.

MAINTENANCE:

REGULATOR SECTION: DISASSEMBLE THE REGULATOR SECTION AS FOLLOWS: TURN OFF AIR SUPPLY. TURN THE ADJUSTING KNOB COUNTERCLOCKWISE TO RELIEVE COMPRESSION ON THE REGULATING SPRING (2). UNSCREW THE BONNET (1), REMOVE THE REGULATING SPRING (2), AND PISTON ASSEMBLY (4). UNSCREW THE VALVE SEAT (5) WITH A 3/8" SOCKET AND REMOVE THE VALVE ASSEMBLY (7) AND VALVE SPRING (8).

CLEAN AND INSPECT EACH PART FOR WEAR OR DAMAGE. REPLACE IF NECESSARY.

CAUTION: WHEN REASSEMBLING, VALVE SEAT (5) SHOULD NOT BE TIGHTENED TO MORE THAN 4 TO 6 INCH POUND TORQUE. BONNET ASSEMBLY (1) SHOULD BE TIGHTENED 50 TO 60 INCH POUNDS TORQUE.

MANUAL DRAIN FILTER SECTION: TO SERVICE THE FILTER SECTION SHUT OFF THE AIR PRESSURE. UNSCREW BOWL ASSEMBLY (14) AND REMOVE "O" RING (9) UNSCREW STUD (13) AND FROM THE STUD REMOVE FILTER ELEMENT (11), LOUVER (10) AND GASKETS (12). THE FILTER ELEMENT SHOULD BE CLEANED PERIODICALLY WITH KEROSENE AND BLOWN OUT WITH COMPRESSED AIR.

AFTER CLEANING, INSPECT EACH PART CAREFULLY, REPLACE ANY DAMAGED PARTS. WHEN REASSEMBLING, TIGHTEN STUD (13) TO 5 TO 10 INCH POUNDS TORQUE.

LUBRICATOR

CAUTION: THIS UNIT HAS A POLYCARBONATE BOWL.

1. BE SURE IT IS NOT MOUNTED WHERE TEMPERATURES OF 125 FOR MORE WILL BE NEAR IT, OR ON A LINE WHERE AIR PRESSURE EXCEEDS 150PSI.
2. BEWARE OF CONDITIONS, FUMES AND FLUIDS THAT WILL HARM THE TRANSPARENT BOWL.
3. TO CLEAN BOWL, RINSE OR WIPE WITH A PETROLEUM SOLVENT ONLY, SUCH AS KEROSENE, OR HOUSEHOLD DISHWASHER DETERGENT.
4. DO NOT USE NEAR, OR CLEAN WITH SUCH MATERIALS AS ACETONE, ALCOHOL, BENZENE, DIOXANE, ETHYL ACETATE, LACQUER THINNER, TOLUENE, CHLORIDE, CARBON TETRACHLORIDE, ALKALIES, AMINES, ESTERS, KETONES AND AROMATIC HYDROCARBONS.
5. DO NOT INSTALL ON A COMPRESSED AIR LINE WHERE THE COMPRESSOR IS LUBRICATED WITH, OR THE AIR CONTAINS, A SYNTHETIC, FIRE-RESISTANT LUBRICANT.

IMPORTANT: INSTALLATIONS INSTRUCTIONS FOR LUBRICATORS.

WHERE AND HOW TO INSTALL:

1. INSTALL AS CLOSE AS FEASIBLE TO EQUIPMENT TO BE LUBRICATED WITH AIR FLOWING IN AND OUT PORTS SO MARKED.
2. TO FILL THE LUBRICATOR, TURN OFF AIR PRESSURE, REMOVE BOWL AND FILL.
3. POUR IN ONLY CLEAN OIL. SAE 10 OR LIGHTER USUALLY IS BEST, NEVER USE ONE OF THE FOLLOWING OILS: CELLULUBE #150 AND #220, KANO KROIL, KEYSTONE PENETRATING OIL #2 OR PYDRAUL AC.
4. AS SOON AS AIR PRESSURE REBUILDS INSIDE THE BOWL, OIL WILL DRIP THROUGH THE SIGHT GAUGE. CONTROL THE RATE OF OIL ENTERING THE AIR STREAM BY TURNING THE ADJUSTMENT SCREW DOWN TO GIVE LESS OIL AND UP TO GIVE MORE OIL. THIS IS A UNIQUE LUBRICATOR. YOU ADJUST THIS TYPE SO THAT WHILE THE SMALLEST AMOUNT OF AIR IS FLOWING THROUGH IT YOU GET THE DESIRED AMOUNT OF OIL FOR THAT FLOW. THE MORE THE AIR FLOW INCREASES, THE MORE OIL YOU WILL NEED AND THE MORE YOU WILL GET AUTOMATICALLY.

HOW TO MAINTAIN:

1. PERIODICALLY CLEAN ADJUSTING SCREW NEEDLE VALVE AND SEAT BY SWISHING A CLEANER AND BLOWING OFF WITH AIR.
2. DRAIN OFF ANY CONTAMINANTS OR WATER IF THEY SETTLE IN THE BOTTOM OF THE BOWL.

FILTER, REGULATOR, AND LUBRICATOR 30-2347-01

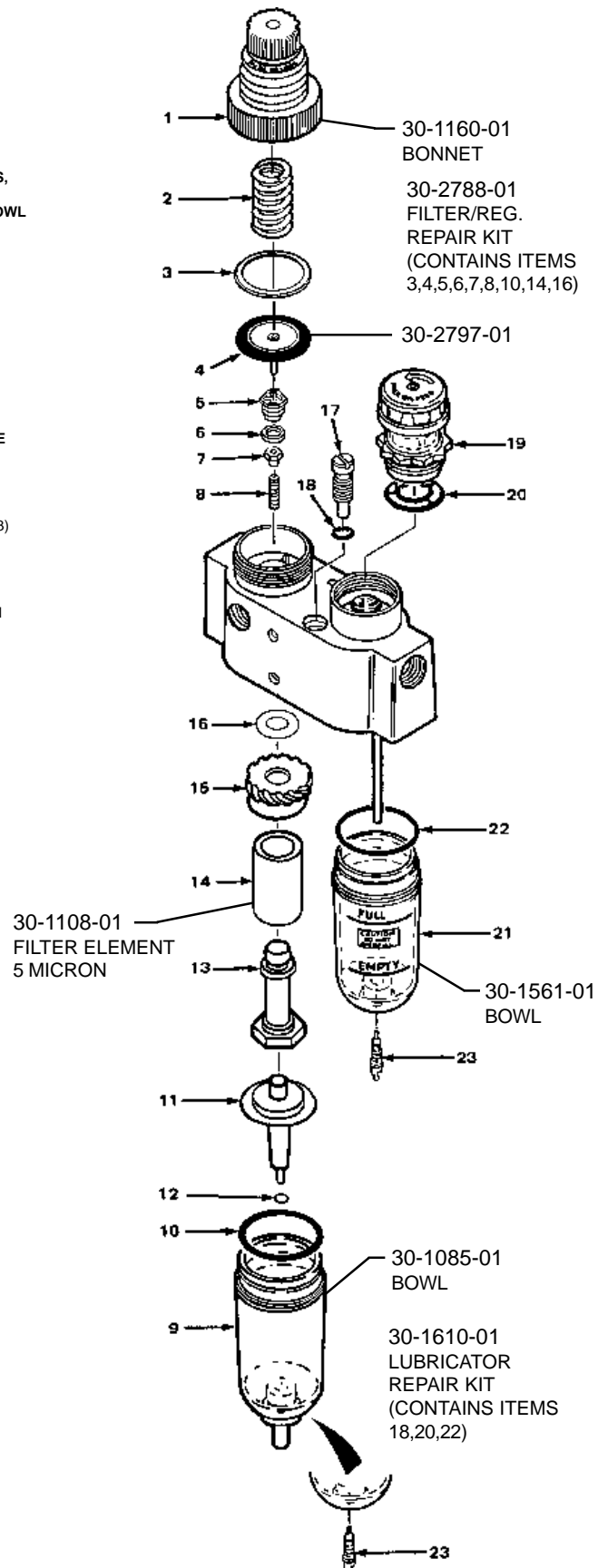

INS-2100-2A

INS-2100-1B