

CLINTON SERVICE GUIDE MODEL 117VS-FOTA-KS U.S. 36200PX

SHEAR CUTTER FOR SHOULDER TAPING OPERATION

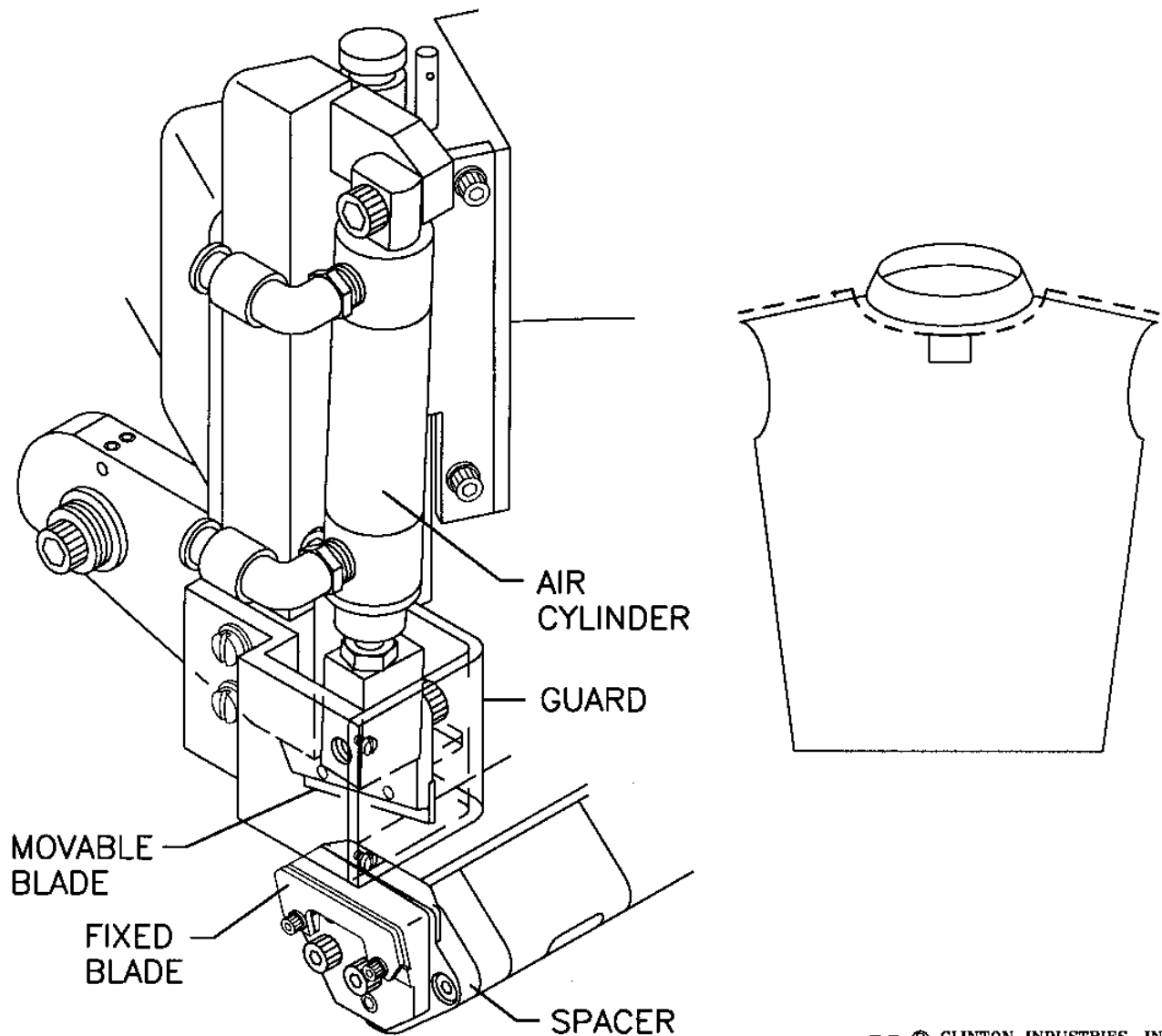

© CLINTON INDUSTRIES, INC.
700 Washington Avenue
Carlstadt, N.J. 07072
Phone: 201-935-4242
FAX: 201-935-3615
Web Site: <http://www.clintonind.com>
Email: general@clintonind.com

STEP 1

DRILLING INSTRUCTIONS
MODEL 117VS
 U.S.36200PX
 10-1535-01

1. PLACE THE DRILL JIG ON THE MACHINE AS SHOWN.
2. ALIGN THE TOP OF THE DRILL JIG WITH THE TOP OF THE MACHINE BED.
3. TIGHTEN THE LOCKNUT ON THE END OF THE SHOULDER SCREW.
4. DRILL TWO HOLES MARKED "A" WITH #29 DRILL SUPPLIED.
5. LOOSEN THE LOCKNUT AND REALIGN THE DRILL JIG SO THAT THE TAPPING GUIDE HOLES WILL ALIGN WITH THE DRILLED HOLES.
6. TAP THE HOLES WITH AN 8-32 TAP USING THE TAP GUIDE HOLES TO GUIDE THE TAP STRAIGHT.
7. REMOVE THE DRILL JIG.

TAP GUIDE HOLES
(LARGER HOLES)

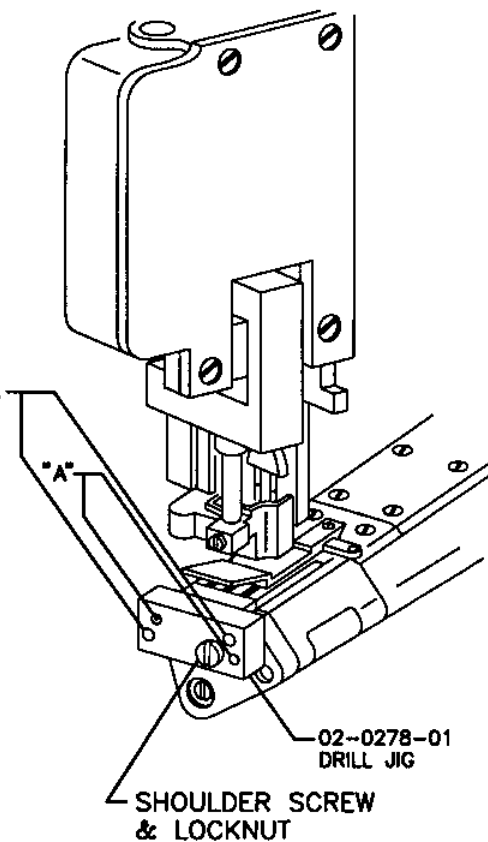
**ADJUSTMENTS****WARNING!!**

TO PREVENT SERIOUS INJURY, DISCONNECT AIR SUPPLY BEFORE MAKING ANY ADJUSTMENTS.

STEP 2

REMOVE THE OLD EXISTING FACE PLATE. THEN MOUNT THE MODEL 117VS CUTTER AS ONE COMPLETE ASSEMBLY WITH THE (4) SCREWS AS SHOWN.

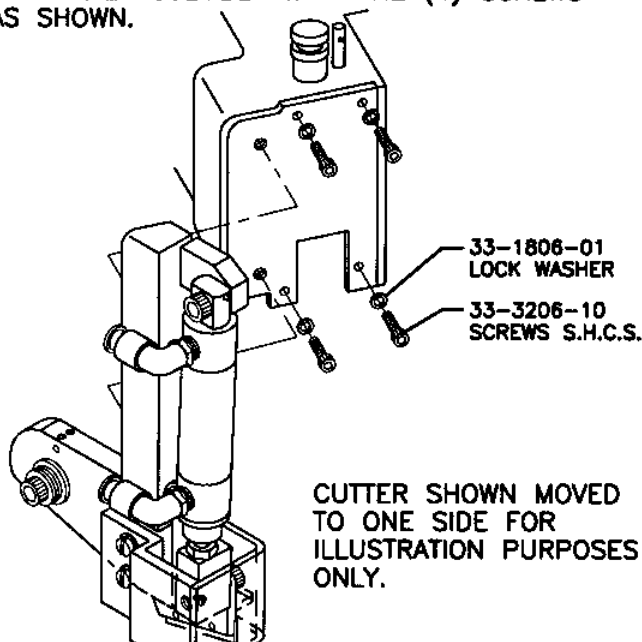
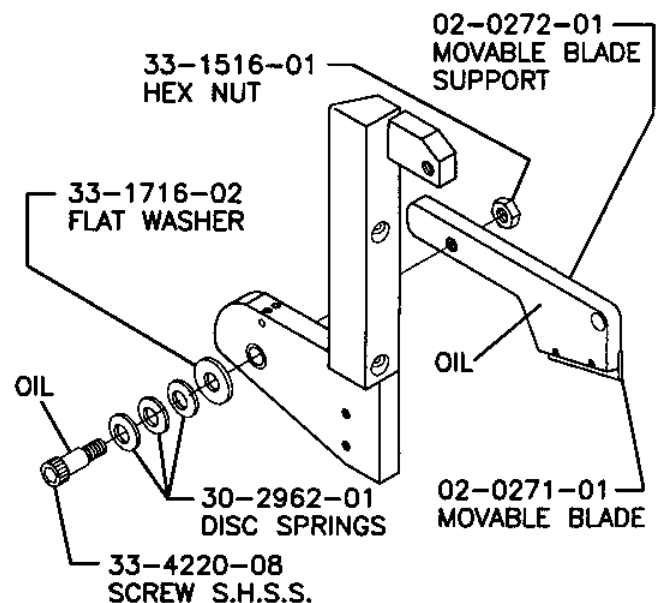
**STEP 3****ADJUSTING THE MOVABLE BLADE**

SHOULDER SCREW 33-4220-08 SHOULD BE SCREWED INTO THE BLADE SUPPORT FINGER TIGHT. THE HEX NUT 33-1516-01 IS USED TO LOCK IN THE ADJUSTED CONDITION.

STEP 4 ADJUSTING THE STATIONARY BLADE

IF THE BLADES ARE NOT TOUCHING EACH OTHER, LOOSEN THE THE (2) SCREWS 33-3210-06. THIS WILL ALLOW THE (2) TOP JACK SCREWS 33-2210-03 TO BE TURNED TO MAKE UP ANY ADJUSTMENT.

ADJUST THE (2) SCREWS 33-2210-03 ON THE RIGHT FOR THE RADIAL ADJUSTMENT OF THE FIXED BLADE AS SHOWN. RETIGHTEN THE (2) SCREWS 33-3210-06. TRY LOWERING THE MOVABLE BLADE SLOWLY (WITHOUT THE AIR BEING ON) FOR TESTING THE SHEARING ACTION. IT MAY REQUIRE SEVERAL ADJUSTMENTS TO GET EXACTLY YOUR CUTTING NEEDS.

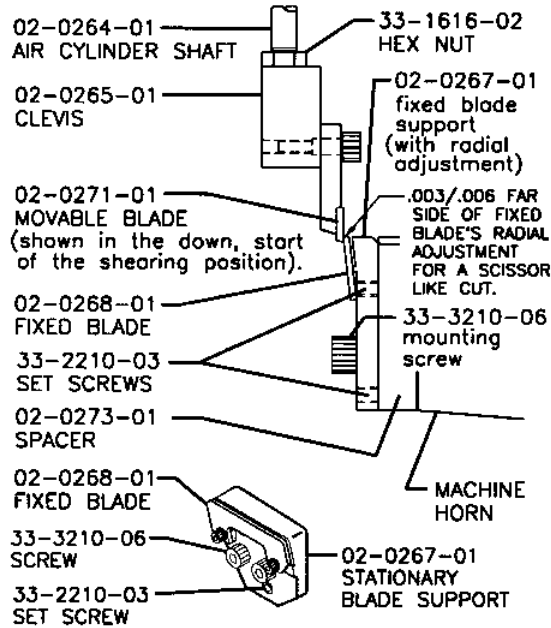

AIR CIRCUIT DIAGRAM MODEL 117VS KS MODEL 117VS F.O.R.G.-KS

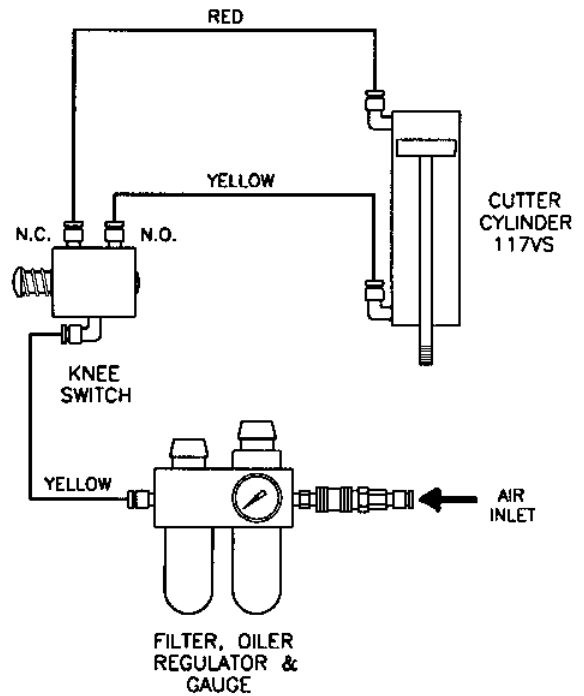

INS-570-3D

FILTER, OILER, REGULATOR, GAUGE ASSEMBLY

80-0181-01
80-0181-10

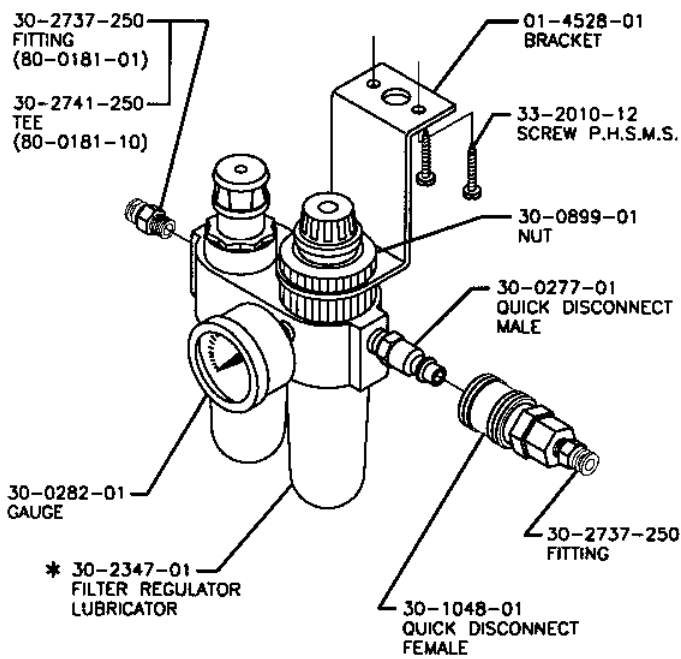

* NOTE: SEE INS-DRAWINGS 2100-1 AND 2100-2 FOR SPARE PARTS

INS-619-1A

4 WAY AIR VALVE, KNEE OPERATED 80-0185-01

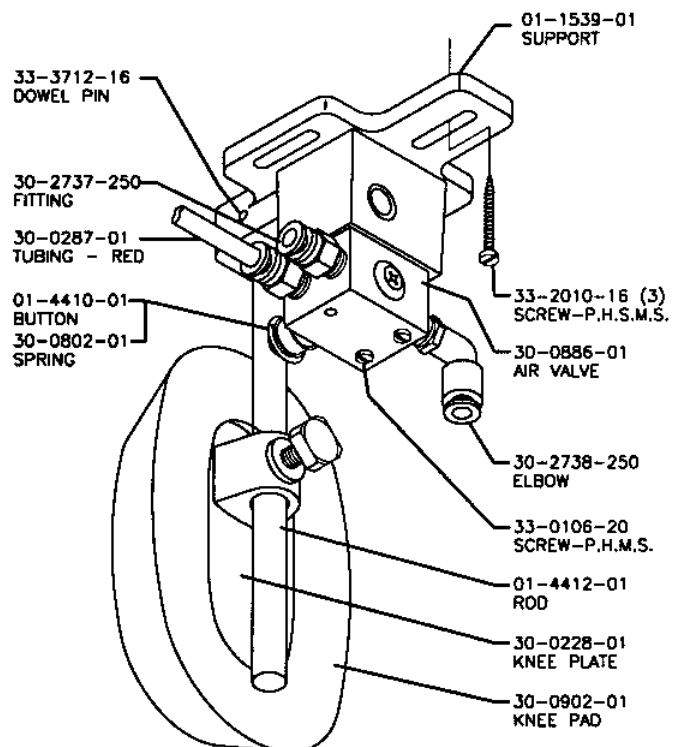

CUTTER ASSEMBLY

MODEL 117VS

U.S. 36200PX

80-0541-01

