

No. 685,258.

Patented Oct. 29, 1901.

R. CONKLIN.
SELF FILLING FOUNTAIN PEN.

(Application filed July 12, 1901.)

(No Model.)

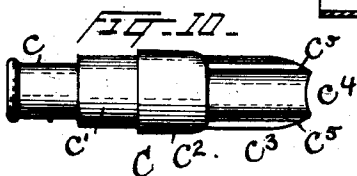
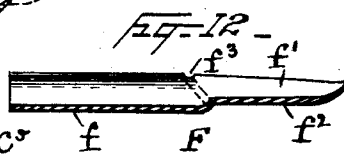
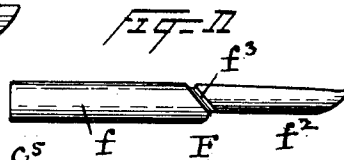
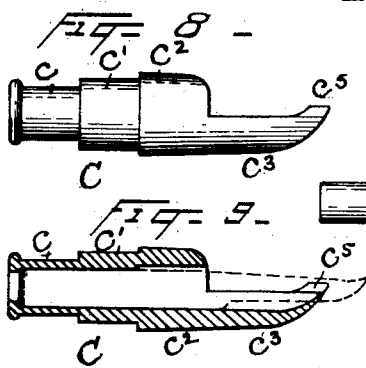
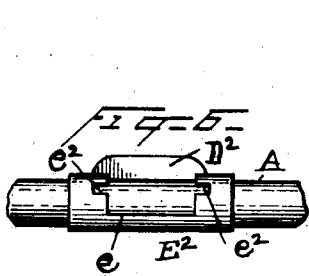
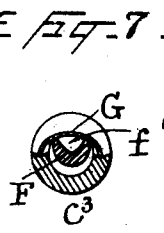
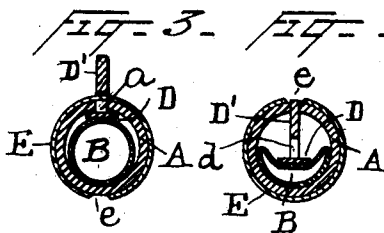
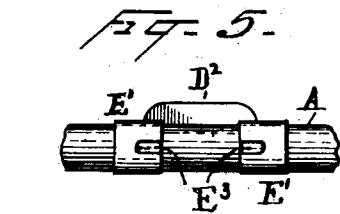
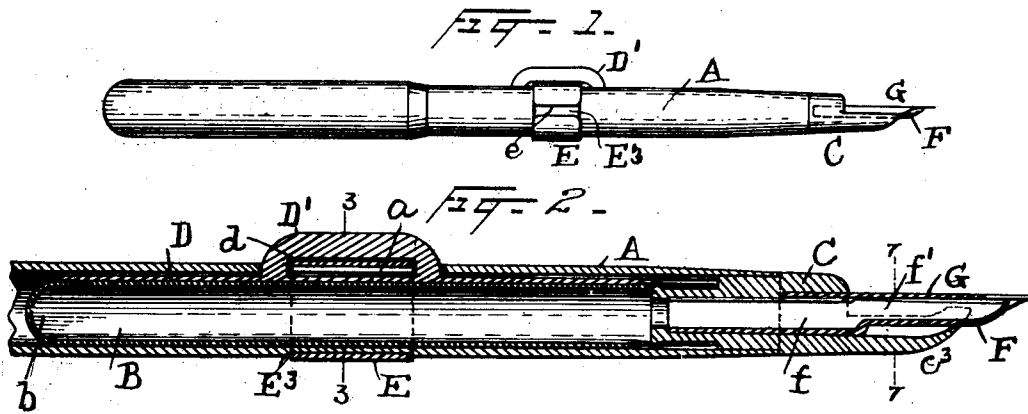

Witnesses
Kornis A. Clark.
M. A. Watkins.

Inventor
Roy Conklin
by
Geo. D. Whitney
Attorney

UNITED STATES PATENT OFFICE.

ROY CONKLIN, OF TOLEDO, OHIO.

SELF-FILLING FOUNTAIN-PEN.

SPECIFICATION forming part of Letters Patent No. 685,258, dated October 29, 1901.

Application filed July 12, 1901. Serial No. 67,982. (No model.)

To all whom it may concern:

Be it known that I, ROY CONKLIN, a citizen of the United States, residing at Toledo, in the county of Lucas and State of Ohio, have
5 invented certain new and useful Improvements in Self-Filling Fountain-Pens; and I do declare the following to be a full, clear, and exact description of the invention, such as
10 appertains to make and use the same, reference being had to the accompanying drawings, and to the letters of reference marked thereon, which form a part of this specification.

15 This invention relates to fountain-pens; and its objects are, first, to provide improved means for filling the pen without opening it and for locking said filling device against accidental actuation, and, second, to provide
20 an improved overflow-chamber for catching the surplus ink when the feed is too rapidly. I am aware that these features are not broadly new with me, and my present invention relates entirely to certain improvements in the
25 details of construction by which certain practical difficulties are overcome.

My invention has to do especially with that class of self-filling pens in which an elastic reservoir is used to hold the ink and also serve
30 as the means for causing a fresh supply of ink to enter it by compressing it before dipping the feed end into a body of ink and then permitting it to expand to its normal dimension. Such a pen is shown in United States
35 Patent to Oliphant, No. 448,360. The reservoir is usually a long cylindrical rubber tube closed at one end and connected at the other end with the pen-section and feed-bar by a
40 fluid-tight joint. The means for compressing the reservoir is a bar laid along in contact with the reservoir inside the pen-handle and having a projection or rib coming out through
45 an opening in the handle, by which the bar can be forced in against the reservoir. In order to lock and release this bar, I provide
50 the projection or rib with a slot, with which engages a ring encircling the pen-handle and rotatable thereon, the ring having a portion removed, so that when the cut-away portion registers with the projection or rib the bar can be pushed in to compress the reservoir, but when the solid portion of the ring under-

lies the projection or rib the bar is positively locked against movement.

Another feature of improvement is the device which catches any overflow of ink from the pen-point. In order to make a free-writing pen, which will always respond when first used and require no shaking or thumping to produce a flow of ink, the feed-groove must
60 be large; but this induces an overflow if the pen is held point downward for any length of time and not in constant use. To avoid the annoyance caused by drops of ink dripping off the pen, it has been proposed to use overflow-pockets formed in an enlargement of the
65 feed-bar. It is found that these pockets in time become obstructed with dried ink, and my invention aims to overcome this by making a single good-sized overflow-chamber on
70 the pen-section and closing it from the air by bringing it in contact with the edges of the pen. Provision is made for conveying back to the reservoir the ink which collects in the
75 chamber.

In the accompanying drawings, Figure 1 is a side elevation of a fountain-pen embodying my improvements. Fig. 2 is a longitudinal section of the same. Fig. 3 is a cross-section
80 on line 3 3, Fig. 2, showing the presser-bar locked. Fig. 4 is a similar section showing said bar released. Figs. 5 and 6 show modified locking-rings. Fig. 7 is a cross-section
85 of the pen, feed-bar, and overflow-chamber on the line 7 7, Fig. 2. Fig. 8 is a side elevation, and Fig. 9 a longitudinal section, and Fig. 10 a top plan view of the pen-section. Fig. 11 is a side elevation, and Fig. 12 a longitudinal section, of the feed-bar.

The handle A is hollow and closed at one end, forming a chamber in which is housed
90 the elastic ink-reservoir B, preferably a rubber tube closed at one end *b* and attached at its other end to the inner end of the pen-section C. A presser-bar D lies along one side
95 of the tube B between it and the handle. The bar has a projecting rib *D'* extending out through a slot *a* in the handle. The rib is slotted, preferably near its middle, and with the slot *d* engages a ring E, encircling the handle and rotatable thereon. The ring is retained in place by suitable means, such as a
100 shallow groove *E'* in the handle, into which the ring is sprung. At one point the ring is

cut away, and if it passes through a slot, such as is shown in Figs. 1 and 2, it must have a segment removed, leaving a gap e at least as wide as the thickness of the projection or rib

5 D' . Then when the ring is rotated, so as to bring this gap in line with the rib, the latter and its bar can be pressed in, as shown in Fig. 4, to compress the elastic reservoir for the purpose of refilling the pen when the bar is released. When the ring is turned, as shown

10 in Figs. 1, 2, and 3, it locks the bar against movement either from accidental pressure or from an intentional but ignorant attempt to move it.

15 Instead of passing the ring through the rib it may engage a slot in the end of the rib, as shown in Fig. 5, and in this case a ring E' may be placed at each end of the rib, if desired.

20 Fig. 6 shows a single ring E^2 with a slot e' to fit the stem of such a notched rib D^2 as is shown in Fig. 5, the slot having notches e^2 to permit the rib to pass through when necessary.

25 The pen-section C has a reduced neck c , over which the end of the reservoir B is stretched, a cylindrical plug portion c' , which closes the end of the handle A , and a shouldered portion c^2 , which abuts against the end

30 of the handle. From one side of the pen-section extends the overflow-chamber c^3 , preferably integral with the pen-section and lying under and partly around the feed-bar F , but with considerable space between them.

35 The tip of the chamber is grooved at c^4 to fit tightly around the under side of the tip end of the feed-bar, the chamber having small upwardly-extending lips c^5 to effect a good joint. Back of these lips the edges of the

40 chamber are grooved to fit tightly against the edges of the pen G , as shown in Fig. 7.

The feed-bar F has a cylindrical stem f with an ample lengthwise passage-way through it to carry the ink to a good-sized groove f' in

45 its tongue f^2 , which lies up under and in contact with the pen. The stem enters the rear portion of the overflow-chamber and wedges the shank of the pen therein, and at the point where the tongue projects from the stem suitable means, such as a groove f^3 on each side

50 of the tongue, are provided to enable the surplus ink collected in the chamber to flow back into the reservoir when the pen is inverted.

55 It will be observed that my overflow-chamber is of ample dimensions, so that it is not liable to clog up; but any tendency to do so can be readily overcome by releasing the presser-bar, dipping the pen into an ink-well,

60 and pumping the ink out of and into the reservoir two or three times.

By dipping the pen into water and operating the presser-bar all parts will be quickly and easily cleansed.

The overflow-chamber above described enables me to use a very free feed, the groove in the feed-bar being large enough to lead the ink quickly to the pen-point, while any surplus is caught by the chamber, and thereby prevented from dropping off the point.

Having thus described my invention, what I claim is—

1. In a self-filling fountain-pen, the combination with an elastic ink-reservoir, of a presser-bar, a slotted rib on said bar, and a rotatable locking-ring engaging with said rib.

2. In a self-filling fountain-pen, the combination with an elastic reservoir, of a presser-bar, a slotted rib on said bar, and a rotatable locking-ring engaging with said rib and having a cut-away portion.

3. In a self-filling fountain-pen, the combination with an elastic reservoir, of a presser-bar, a slotted rib on said bar, and a rotatable locking-ring passing through said slot and having a gap adapted to permit the rib to pass through it.

4. In a self-filling fountain-pen, the combination with a handle having a shallow groove and a longitudinal slot, of a locking-ring rotatable in said groove, a presser-bar having a rib engaging with said ring, and an elastic reservoir in said handle.

5. In a fountain-pen, the combination with the pen proper, of a feed-bar grooved on its upper side, a pen-section receiving the pen and the stem of the feed-bar, and an overflow-chamber extending from the pen-section and having grooves in its upper edges to receive the edges of the pen.

6. In a fountain-pen, the combination with the pen proper, of a grooved feed-bar, and pen-section holding the pen and the feed-bar and provided with an integral hollowed extension fitting closely at its end against the under side of the feed-bar and also having grooves fitting against the edges of the pen so as to form a closed overflow-chamber.

7. In a fountain-pen, the combination with the pen-section having an extension provided with a notched tip and grooved edges, of a feed-bar having a groove in its upper side and side grooves connecting said upper groove with the extension on the pen-section, said bar fitting closely in the notch in said extension.

In testimony whereof I affix my signature in presence of two witnesses.

ROY CONKLIN.

Witnesses:

GEO. P. WHITTLESEY,
EMORY H. BOGLEY.