

1,263,261.

Patented Apr. 16, 1918.
 2 SHEETS—SHEET 1.

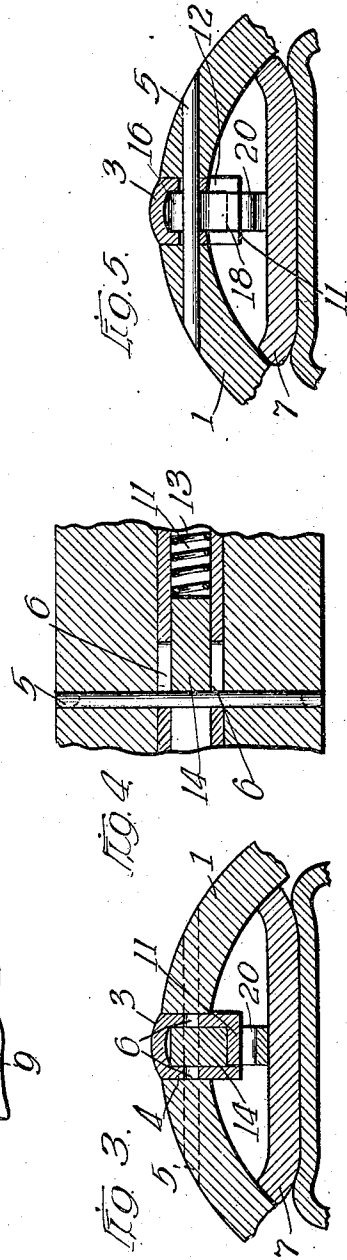
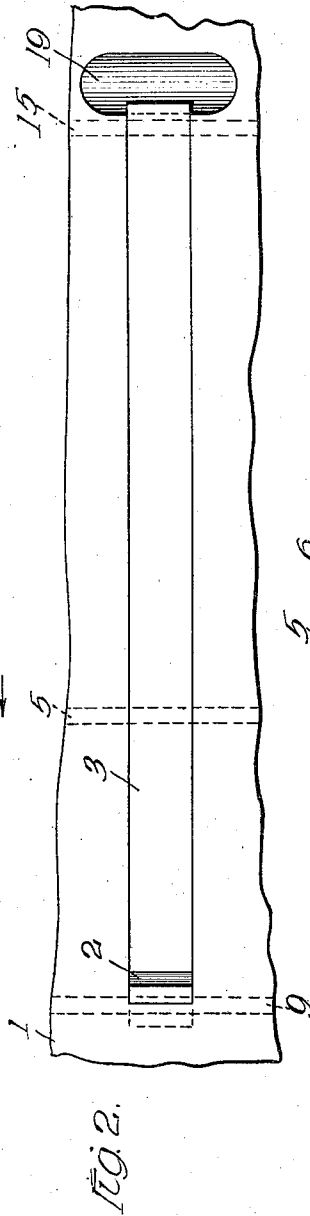
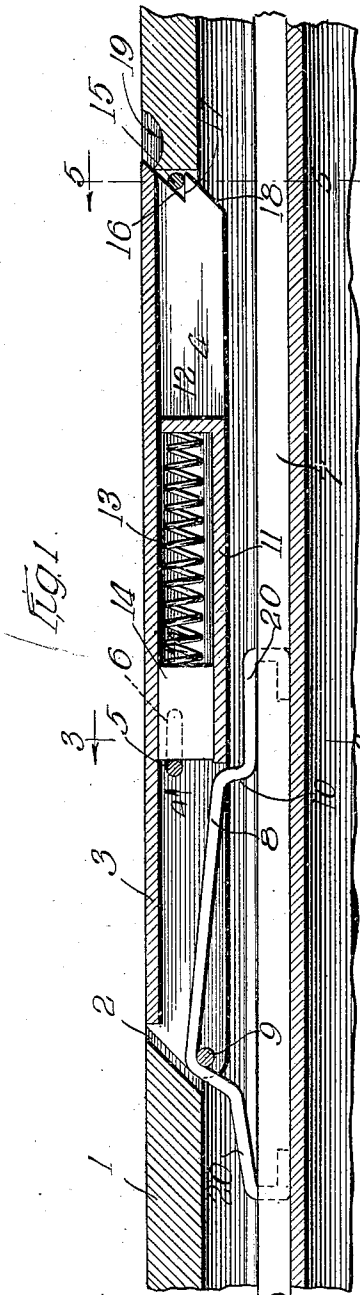

Witnesses:
 Harry B. L. White
 W. P. Kilroy

Inventor
 Rudolph W. Lotz
 By Atty.

R. W. LOTZ.
 FOUNTAIN PEN.
 APPLICATION FILED MAR. 11, 1918.

1,263,261.

Patented Apr. 16, 1918.
 2 SHEETS—SHEET 2.

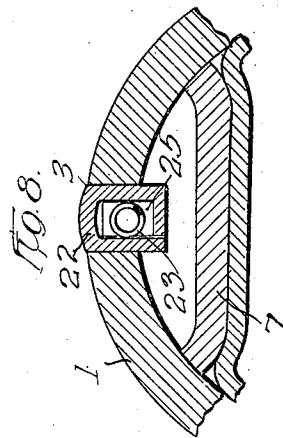
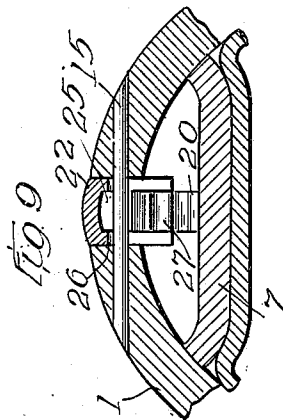
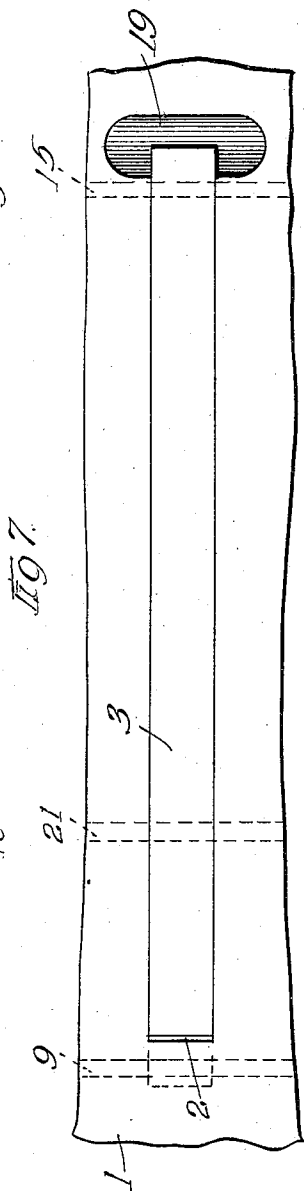
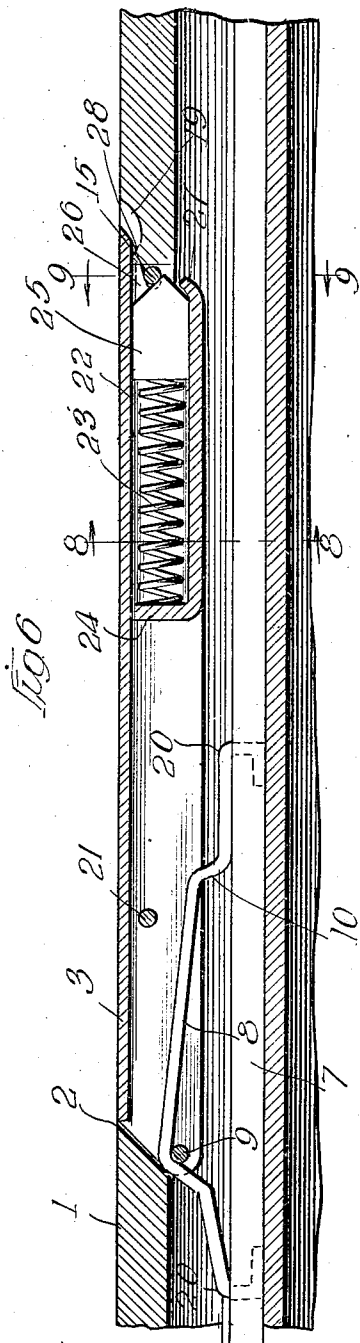

Witnesses
 Harry R. L. White
 W. P. Kilroy

Inventor
 Rudolph W. Lotz
 By _____ Atty.

UNITED STATES PATENT OFFICE.

RUDOLPH WM. LOTZ, OF CHICAGO, ILLINOIS.

FOUNTAIN-PEN.

1,263,261.

Specification of Letters Patent.

Patented Apr. 16, 1918.

Application filed March 11, 1918. Serial No. 221,804.

To all whom it may concern:

Be it known that I, RUDOLPH WM. LOTZ, citizen of the United States, residing at Chicago, in the county of Cook and State of Illinois, have invented certain new and useful Improvements in Fountain-Pens; and I do hereby declare the following to be a full, clear, and exact description of the invention, such as will enable others skilled in the art to which it appertains to make and use the same.

This invention relates to improvements in self-filling fountain pens, and has for its object to provide a fountain pen of this character in which the collapsible ink reservoir is collapsed by means of a pressure bar actuated by a lever and fulcrumed in a slot in the barrel, and in which the lever is firmly automatically locked in its closed position when moved thereto.

A further object of the invention is to provide connection between one end of the lever and the sack-collapsing bar or pressure bar whereby the latter is supported and held by the lever, when closed firmly abutting against the inner wall of the barrel, and is thus prevented from effecting ejection of ink or flooding of the pen by the imposition of its weight on the sack when the latter is expanded and filled, or partially filled, with ink.

A further object of the invention is to provide simple, cheap and efficient means for firmly locking the lever in its closed position against accidental opening, and preferably in such a manner as to automatically effect unlocking of the lever substantially simultaneously with the beginning of its opening movement thereof by insertion of the finger nail underneath one end of the lever in a well-known manner.

The invention consists in the features of construction and combinations of parts hereinafter fully described and particularly claimed.

In the accompanying drawings illustrating the invention:

Figure 1 is a fragmentary detail central longitudinal section of a fountain pen constructed in accordance with my invention.

Fig. 2 is a fragmentary detail view in elevation of the same showing the slot and operating lever housed therein.

Figs. 3, 4 and 5 are respectively fragmentary detail sections on the lines 3—3, 4—4 and 5—5 of Fig. 1.

Fig. 6 is a view similar to Fig. 1 showing another embodiment of the invention.

Fig. 7 is a fragmentary view in elevation of the same.

Figs. 8 and 9 are fragmentary detail sections on the lines 8—8 and 9—9 respectively of Fig. 6.

Referring now to said drawings, 1 indicates the barrel of a fountain pen which is provided with a longitudinal slot 2 in which the lever 3 is pivotally mounted between its ends.

The said lever is preferably hollow and consists of a channeled element having parallel side flanges 4 and a middle portion or web which is disposed substantially flush with the outer peripheral wall of the barrel 1 when the lever is in closed position. A pivot pin 5 spans the slot 2 between its ends and passes through longitudinal slots 6 in the flanges 4 of the lever. The pressure or sack-collapsing bar 7 is provided with a wire loop 8 projecting from one face thereof between the ends of said bar and is engaged with the lever 3 by means of a pin 9 or equivalent device spanning the flanges 4 of said lever and passing through said loop 8. Said loop is preferably of a length substantially equal to the movement of the pin 9 longitudinally of the barrel when describing an arc of substantially ninety degrees when turned from its closed to its open position, the end wall 10 of said loop 8 constituting a stop for limiting the opening movement of the lever.

Spanning the flanges 4 at their inner edges between the ends of the lever 3 and from a point contiguous to the slots 6 to a point contiguous to one end of the lever is a flange 11 terminating in a lip 12 which is bent upwardly to extend between the flanges 4. The said flange 11 and lip 12 coact with the side flanges and middle portion of the lever to form a short box which contains the helical compression spring 13 and a slidable plunger 14 which is held by said spring 13 normally in engagement with the pivot pin 5 of the lever and serves to hold the latter normally at one limit of its longitudinal movement relatively to the barrel 1.

Spanning one end of the slot 2 in the barrel 1 is a pin 15 which is adapted to engage in a recess 16 in one end of the lever 3, said recess having a wall 17 extending parallel with the axis of the barrel 1 when the lever is in closed position. Below said

wall 17 is an inclined surface 18 adapted to engage the pin 15 when the lever is moved to closed position to cause the lever to move slightly longitudinally during its closing movement thereby causing the outer end of the shoulder 17 to pass the pin 15, whereupon the lever will be moved to the position shown in Fig. 1 by the action of the spring 13 in an obvious manner and effectually lock the lever 3 against accidental opening movement. The end of the lever constituting the upper end of the recess 16 projects into a transverse recess 19 in the outer peripheral wall of the barrel into which a finger nail is adapted to be inserted underneath said end of said lever for the purpose of turning the latter on its pivot. During engagement of the finger nail with the end of the lever the latter is primarily moved longitudinally until the shoulder 17 has passed the pin 15 whereupon a continued movement of the lever will cause the same to swing on its pivot and thus move the bar 7 to collapse the sack.

The distance from the end of the slot in which the pivot pin 5 normally rests to the pin 9 is such with relation to the diameter of the barrel as to cause the sack to be completely collapsed when the lever attains a position substantially perpendicular to the barrel. The loop 8 is preferably made of an elastic spring wire which is formed to provide extension portions 20 normally resting upon the surface of the bar opposing the slot 2, and the distance between the opposed surfaces of the middle portion of the loop 8 and the opposed face of the bar is preferably slightly less than the normal distance between said face of said bar and the pin 9 when the lever is in closed position. The bar 7 will, when the lever is in closed position as shown in Figs. 3 and 5, lie in contact along its side edges with the inner peripheral wall of the barrel, and thus its movement toward the slotted side of the barrel is limited. Hence, in effecting closure of the lever 3 the loop 8 will be slightly flexed, as shown in Fig. 1, thus tending to throw the lever normally to a partially open position. The resistance to closure of the lever thus provided serves to more firmly engage the wall 17 with the pin 15, and to more effectually lock the lever against accidental opening.

The main purpose of the flexing of the loop 8 as the lever is closed is, however, to hold the pressure bar 7 very firmly in contact with the inner wall of the barrel so as to prevent vibration thereof against the sack or ink reservoir in writing which frequently causes flooding of the pen.

The invention may be also embodied as shown in Figs. 6 to 9 inclusive, in which the lever 3 pivotally mounted on the pivot pin 21 spanning the slot 2 in the barrel

1 is equipped at one end with a box-like portion 22 containing the helical compression spring 23 which bears at one end on the lip 24 and at its other end against a plunger 25 having a recessed and tapered end 26. The latter is adapted to spring over the pin 15 spanning the end of the slot 2 when the lever is closed to engage said pin in the recess in the end thereof to latch the lever in its closed position, said plunger being limited in its outward movement by the lip or stop projection 27 at the outer end of the lower wall of the box 22. Preferably in this construction the loop 8 on the pressure bar 7, which is engaged with the pin 9 spanning the flanges of the lever 3, is not distorted or flexed to any appreciable extent when the lever is in closed position for the reason that it must not exert force sufficient to overcome the resistance to opening of the lever offered by the engagement of the tapered wall of the recess of the plunger 25 with the pin 15. Hence the flexing, if any, of the loop 8 should be almost imperceptible and may be entirely omitted. However, I prefer to render the shoulder engaged by the tapered end of the plunger 25 of such inclination as to require the exercise of considerable force to effect opening of the lever. The plunger 25 is preferably provided with a projection or lip 28 extending underneath the top wall of the lever at the projecting end thereof, which normally lies in the transverse recess 19 at the end of the slot 2 and in such position relatively to the extreme end of the lever as to cause said projection 28 to be engaged by the fingernail and moved against the action of the spring 23 to release the plunger 25 from engagement with the pin 15 at the same time that the lever is engaged for the purpose of turning the same to open position to cause the bar 7 to collapse the ink reservoir.

Obviously the invention may be still otherwise embodied than in the constructions described and shown, without departing from the invention.

In the accompanying drawings I have omitted from illustration the pen section, feed and nib, all of which are necessary to the complete device, but are so well-known in the art as to require neither illustration nor description.

I claim as my invention:

1. A self-filling fountain pen including a barrel having a longitudinal slot, a collapsible ink-reservoir and a pressure bar within the barrel, a lever pivotally mounted between its ends in said slot and engaged at one end with said pressure bar for moving the same to collapse the sack, a latch-element spanning said slot, means on said lever disposed for engagement by said latch-element as said lever is turned to closed position

tion for automatically firmly retaining said lever in said position, and a spring operatively disposed relatively to said means on said lever for maintaining the same in engaging relation to said latch-element.

2. A self-filling fountain pen including a barrel having a longitudinal slot, a collapsible ink-reservoir and pressure bar housed by the barrel, a lever fulcrumed between its ends in said slot and mounted to move longitudinally relatively to its fulcrum, connection between one end of said lever and said pressure bar for moving the latter to collapse the ink-reservoir as said lever is swung through an arc approximating ninety degrees from closed to open position, coacting means on said lever and said barrel for locking said lever in closed position, and a spring associated with the lever and its fulcrum for automatically engaging said coacting means with each other to lock said lever as it is moved to closed position.

3. A self-filling fountain pen including a barrel having a longitudinal slot, a collapsible ink-reservoir and pressure bar housed by the barrel, a lever fulcrumed between its ends in said slot and mounted to move longitudinally relatively to its fulcrum, connection between one end of said lever and said pressure bar for moving the latter to collapse the ink-reservoir as said lever is swung through an arc approximating ninety degrees from closed to open position, coacting means on said lever and said barrel for locking said lever in closed position, and a spring associated with the lever and its fulcrum for normally maintaining said lever at one limit of its longitudinal movement relatively to its fulcrum, said coacting means including means for automatically effecting reciprocation of said lever relatively to its fulcrum as said lever is moved to closed position for automatically engaging said coacting means with each other to lock said lever in said position.

4. A self-filling fountain pen including a barrel having a longitudinal slot, a collapsible ink-reservoir and pressure bar housed by the barrel, a lever fulcrumed between its ends in said slot and mounted to move longitudinally relatively to its fulcrum, connection between one end of said lever and said pressure bar for moving the latter to collapse the ink-reservoir as said lever is swung through an arc approximat-

ing ninety degrees from closed to open position, coacting means on said lever and said barrel for locking said lever in closed position, and a spring associated with the lever and its fulcrum for normally maintaining said lever at one limit of its longitudinal movement relatively to its fulcrum, said coacting means including means for automatically effecting reciprocation of said lever relatively to its fulcrum as said lever is moved to closed position for automatically engaging said coacting means with each other to lock said lever in said position, said coacting means relatively arranged to cause the said coacting means to be released from each other as the lever is engaged at one end preparatory to opening the same.

5. A self-filling fountain pen including a barrel having a longitudinal slot, a collapsible ink-reservoir and pressure bar housed by the barrel, a lever having a longitudinal slot between its ends, a fulcrum pin spanning the slot in the barrel and passing through the slot in the lever for permitting limited longitudinal movement of said lever relatively to said barrel, connection between one end of said lever and said pressure bar for moving the latter to collapse the ink-reservoir as said lever is turned to open position, a spring operatively disposed to maintain said lever at one limit of its longitudinal movement relatively to the barrel, and coacting formations on said lever and barrel adapted to automatically interengage to lock said lever in closed position as the latter is moved thereto, said lever being adapted to be released by moving the same longitudinally against the action of said spring.

6. A self-filling fountain pen including a barrel having a longitudinal slot, a collapsible ink-reservoir and a pressure bar within the barrel, a lever pivotally mounted between its ends in said slot and engaged at one end with said pressure bar for moving the same to collapse the sack, a latch element rigid with the barrel and disposed in the lever slot, and companion means for engaging said lever with said latch-element manually movable in one direction relatively to the barrel for releasing the lever, and a spring operatively associated with said last-named means for normally maintaining the same in engaging relation to said rigid latch-element.

RUDOLPH WM. LOTZ.