



XCITE Owner's Manual

Xcite 1100-6 System

- 1107-4-T/C Exciter Head
 - 1201B Hydraulic Power Supply
 - 1104-MOD4 Master Controller
 - 2522 Load Cell
-

Copyright 1997
Xcite Systems Corporation

This document contains proprietary information of Xcite Systems Corporation and is tendered subject to the conditions that the information (a) be retained in confidence (b) not be reproduced or copied in whole or in part and (c) not be used or incorporated into any product except under an express written agreement with Xcite Systems Corporation.

Table of Contents

- 1. Warranty P-7**
 - 1.1. Xcite Products..... P-7
 - 1.2. Third Party Hardware Products..... P-7
 - 1.3. IMPORTANT LIMITATIONS P-7
 - 1.4. NOTICE OF LIMITED WARRANTY..... P-8
- 2. Receiving..... P-8**
 - 2.1. Receiving Inspection Procedure P-8
 - 2.2. Shipping Container P-8

1100-4, 1100-6 and 1100-7 Linear Exciter System
Setup and Operation

- 1. Introduction.....S&O-1**
- 2. System DescriptionS&O-1**
- 3. Setup Procedure.....S&O-2**
 - 3.1. Mounting the 1106-4-T/C, 1107-4-T/C or 1114-4-T/C Exciter Head..... S&O-2
 - 3.2. 1201B or 1301B Hydraulic Power Supply Commissioning Procedure.. S&O-2
 - 3.3. 1001P Field Test Power Supply Commissioning Procedure..... S&O-3
 - 3.4. Starting the Hydraulic Power Supply S&O-4
 - 3.5. Hydraulic Hookup..... S&O-4
 - 3.6. Cable Hookup S&O-5
- 4. Operation Procedure.....S&O-5**
 - 4.1. Switch Settings S&O-5
- 5. Shutdown Procedures.....S&O-6**
- 6. Troubleshooting.....S&O-7**
- 7. Storage Instructions.....S&O-7**

1100, 1200 and 1300 Exciter Heads

- 1. Introduction..... EH-1**
- 2. Theory of Operation EH-2**
 - 2.1. Introduction EH-2
 - 2.2. Circuit Description (Electric)..... EH-2
 - 2.2.1. Head EH-2
 - 2.2.2. Displacement Kit..... EH-2
 - 2.3. Circuit Description (Hydraulic) EH-2
 - 2.3.1. Head EH-2
 - 2.3.2. Displacement Kit..... EH-3
- 3. Major Components EH-3**
 - 3.1. Actuator..... EH-3
 - 3.2. Servovalve EH-3

- 3.3. Load Cell..... EH-3
- 3.4. Displacement Transducer Kit..... EH-4
- 4. Operation..... EH-4**
- 4.1. Operating Precautions EH-5
- 5. Care and Maintenance..... EH-6**
- 5.1. Each Usage EH-6
- 5.2. Each Month..... EH-6
- 5.3. Periodic..... EH-6
- 6. Specifications EH-6**

1201B Hydraulic Power Supply

- 1. Introduction..... HPS-1**
- 2. Commissioning Procedure HPS-1**
- 2.1. Initial Setup of Hydraulic Power Supply HPS-1
- 2.2. Starting the Hydraulic Power Supply HPS-2
- 2.3. Hydraulic Hookup..... HPS-2
- 2.4. Cable Hookup HPS-3
- 3. Theory of Operation HPS-3**
- 3.1. Hydraulic System HPS-3
- 3.2. Electrical System HPS-3
- 4. Description HPS-5**
- 4.1. Major Components..... HPS-5
- 4.2. Control Components..... HPS-5
- 4.3. Monitoring Devices HPS-5
- 5. Care and Maintenance..... HPS-6**
- 5.1. Operating Care HPS-7
- 5.2. Maintenance HPS-7
- 6. Troubleshooting..... HPS-8**
- 6.1. Unit Overheats..... HPS-8
- 6.2. Pump de-energizes..... HPS-8
- 7. Specifications HPS-9**
- 8. Drawings..... HPS-9**

Master Controller

- 1. Introduction..... MC-1**
- 2. Theory of Operation MC-1**
- 2.1. Configurations..... MC-1
- 2.1.1. Single Loop..... MC-1
- 2.1.2. Dual Loop MC-1
- 3. Description MC-2**
- 3.1. Front Panel MC-3

3.1.1.	Static Signal Level Meter (M-101)	MC-3
3.1.2.	Static Set Point (R301)	MC-3
3.1.3.	Dynamic Signal Level Meter (M-102)	MC-3
3.1.4.	Dynamic Set Point (R303)	MC-3
3.1.5.	Excitation Mode (SW304)	MC-3
3.1.6.	Interlock (L301)	MC-4
3.1.7.	Dither - ON/ OFF (SW308)	MC-4
3.1.8.	Static Set Point (R301)	MC-4
3.1.9.	Static Gain	MC-4
3.1.10.	Load Cell.....	MC-5
3.1.11.	Calibrate/ Operate (SW307)	MC-5
3.1.12.	Power (SW301)	MC-5
3.1.13.	Pump	MC-6
3.1.14.	Dynamic Set Point (R303)	MC-6
3.1.15.	Frequency Range - HIGH/ LOW (SW309).....	MC-6
3.2.	Rear Panel.....	MC-6
3.2.1.	Exciter Head (J305)	MC-6
3.2.2.	Displacement (J311)	MC-6
3.2.3.	Calibration Resistor (J304)	MC-6
3.2.4.	Static Preload (SW310)	MC-6
3.2.5.	Interlock (J306)	MC-7
3.2.6.	Power (J307)	MC-7
3.2.7.	Fuse (F301)	MC-7
3.2.8.	Program Input (J308).....	MC-7
3.2.9.	Controlled Variable - Static	MC-8
3.2.10.	Controlled Variable - Dynamic	MC-8
3.2.11.	Compression Output (J310).....	MC-9
3.2.12.	Standby Level (R313).....	MC-9
3.2.13.	Load Cell Output (J303).....	MC-9
3.2.14.	Power Amp - INT/ EXT (SW312)	MC-9
3.2.15.	Power Amp - Input (J312)	MC-9
3.2.16.	EXT Set Point - Static (J313).....	MC-10
3.2.17.	EXT Set Point - Dynamic (J314).....	MC-11
4.	Operation.....	MC-11
4.1.	Concept of Operation.....	MC-11
4.2.	System Interconnection	MC-12
4.3.	Operation - Force Control	MC-12
4.3.1.	Set Controls	MC-12
4.3.2.	Depress the Power Switch.....	MC-13
4.3.3.	Adjust Load Cell.....	MC-13
4.3.4.	Depress Pump Start Button	MC-13
4.4.	Operation - Displacement Control.....	MC-14
4.4.1.	Set Controls	MC-14
4.5.	Operation - External Variable.....	MC-15

- 4.6. Computer Control - External Set Points (Static and Dynamic) MC-15
- 5. Theory of Operation MC-16**
 - 5.1. Circuit Descriptions MC-16
 - 5.1.1. VR101 (Voltage Regulator) MC-16
 - 5.1.2. SW310 (Preload Switch) MC-16
 - 5.1.3. A109 (Amplifier) MC-16
 - 5.1.4. A104 and A105 (Static Control Loop) MC-17
 - 5.1.5. A401 and A402 (Dynamic Loop) MC-17
 - 5.1.6. A107 (Inverter Buffer) MC-18
 - 5.1.7. A106 and U103 (Peak Detector Circuit) MC-18
- 6. Specifications MC-19**
- 7. Drawings MC-19**
- 8. Parts List MC-21**
- 9. Calibration MC-26**
 - 9.1. Equipment Needed MC-26
 - 9.2. Master Controller MC-27
 - 9.2.1. Meter Zero Adjustments MC-27
 - 9.2.2. +/-15 Volt Supply Check MC-27
 - 9.2.3. +/- 60 Volt Supply Verification MC-28
 - 9.2.4. Load Cell Excitation Voltage Verification MC-28
 - 9.2.5. Master Controller Board 110-04 Calibration Procedure MC-28
 - 9.2.6. Master Controller Board 110-02 Calibration Procedure MC-31
 - 9.2.7. Master Controller Board 110-01 Calibration Procedure MC-31
 - 9.3. Exciter Head Calibration Procedure MC-38
 - 9.3.1. Load Cell Amplifier Calibration MC-38
 - 9.3.2. Static Loop Gain Calibration MC-40
 - 9.3.3. Static Set Point Level Calibration MC-42
 - 9.3.4. High Frequency Dynamic Level Calibration MC-42
 - 9.3.5. Low Frequency Dynamic Calibration MC-43
 - 9.4. Displacement Calibration Procedure MC-44
 - 9.4.1. LVDT Symmetry Verification and Adjustment MC-44
 - 9.4.2. Displacement Zero Calibration MC-45
 - 9.4.3. Displacement Scaling Calibration MC-45
 - 9.4.4. Final External Static Control Variable Calibration MC-45
 - 9.4.5. Dynamic Displacement Calibration MC-45
 - 9.4.6. External Static and Dynamic Set Point Calibration MC-46

1. Warranty

1.1. Xcite Products

Xcite Systems Corporation warrants that any Xcite manufactured product will conform to Xcite’s written specifications applicable at the time of shipment and will be free from defects in material or workmanship for one year. During the Xcite warranty period, Xcite, or its agent, will repair or replace, at its option, any defective product when returned to the factory, freight prepaid by the buyer, and will return the product freight collect. Xcite assumes no liability for loss or damage during shipment to and from the factory. If insurance on the return shipment is required, it must be specified by the buyer.

1.2. Third Party Hardware Products

Xcite will transfer the original manufacturer’s warranty for third party hardware (not manufactured by Xcite) to the buyer. The warranty policy of those companies in effect at the time of shipment will apply to their products, and Xcite assumes no additional responsibility. Xcite will indicate on its invoice the warranty terms relevant to specific Third Party Hardware items.

1.3. IMPORTANT LIMITATIONS

- 1.3.1.** The warranty period commences upon the day of shipment from Xcite without respect to any acceptance criteria or payment provisions in any particular contract.
- 1.3.2.** The warranty period does not apply to normal wear items or to damage caused by abuse, neglect or accident.
- 1.3.3.** Xcite’s responsibility is limited to the above obligations, and Xcite cannot be held responsible for special or consequential or other damages.

ALL OTHER EXPRESS OR IMPLIED WARRANTIES, INCLUDING MERCHANTABILITY AND FITNESS FOR PURPOSE, ARE EXCLUDED.

1.4. NOTICE OF LIMITED WARRANTY

THE FOLLOWING ITEM(S) INCLUDED IN THIS XCITE PRODUCT OR SYSTEM ARE EXCLUDED FROM OUR ONE YEAR WARRANTY BECAUSE THEY ARE NORMAL WEAR ITEMS:

- 1) All system seals
- 2) Servo valve*

*The servo valve used on this system will be damaged if any particle(s) larger than 10 microns are permitted to enter the valve. Extreme care should be exercised when the hydraulic hoses are connected to ensure no foreign particles enter the connections. It is recommended to always wipe the hydraulic couplings with lint free towel before making connections. Always use the protective dust covers on the hoses (the dust covers can be connected together when operating the system). Any damage to the servo valve as a result of contamination is specifically excluded from warranty.

2. Receiving**2.1. Receiving Inspection Procedure**

Xcite Systems Corporation products are shipped in a manner designed to protect against all normal shipping hazards. Immediately upon receipt, inspect all equipment and note any visible damage. In accordance with the instructions in this manual, test its functional operation. Keep all documents in relation to this shipment. If shipping damage is apparent, file a claim with the carrier's claim agent and send a copy to Xcite Customer Service. Be sure to include the product name, model number and serial number on all correspondence.

2.2. Shipping Container

Shipping containers are supplied with all Xcite products. Store these containers and inserts in a dry area for possible later use.

1100-4, 1100-6 & 1100-7 Linear Exciter System Setup and Operation



1100-4, 1100-6 & 1100-7 Linear Exciter System

1. Introduction

The function of this system is to impart a controlled force into structures such as machine tools, automobiles and truck suspensions. The force generation is accomplished by a closed loop electrohydraulic system which can apply a static preload in addition to dynamic force up to 1200 Hz under either sine or random conditions.

The static control loop of the system utilizes either the built-in Displacement Transducer (LVDT) or strain gage load cell as feedback and controls the static position of the mass while the dynamic control loop utilizes the built-in load cell as feedback to measure and control the dynamic force applied to the structure under test.

2. System Description

1100-4 System	<ul style="list-style-type: none">• 1106-4-T/C Exciter Head• 1104-Mod4 Master Controller• 1001P Field Test Power Supply or 1201B or 1301B Laboratory Power Supply
1100-6 System	<ul style="list-style-type: none">• 1107-4-T/C Exciter Head• 1104-Mod4 Master Controller• 1001P Field Test Power Supply or 1201B or 1301B Laboratory Power Supply
1100-7 System	<ul style="list-style-type: none">• 1114-4-T/C Exciter Head• 1104-Mod4 Master Controller• 1001P Field Test Power Supply or 1201B or 1301B Laboratory Power Supply

This manual contains a section of detailed information on each of these components, and the user should familiarize himself or herself with this information before using the system.

If the user has purchased the Exciter Head and Master Controller without an Xcite Hydraulic Power Supply, any reference to the power supply in this manual applies to whatever source of hydraulic power the user has elected.

3. Setup Procedure

3.1. Mounting the 1106-4-T/C , 1107-4-T/C or 1114-4-T/C Exciter Head

- 3.1.1. The Exciter head may be mounted in any orientation but care must be taken to provide strain relief on hoses and cables if the unit is mounted at heights which would add significant loads to the hoses and cables.
- 3.1.2. The Exciter mounting base has clearance holes for mounting. Secure the unit so that it will not “walk” when exciting resonant frequencies of the structure.
- 3.1.3. **CAUTION!** Care must be taken that the Exciter is firmly and squarely attached to the back up fixturing. Any clearances or dead zones in the attachment or dynamics of any fixtures will cause distortion of the force waveform.

3.2. 1201B or 1301B Hydraulic Power Supply Commissioning Procedure

- 3.2.1. Remove all packing material from inside and outside the pump cabinet.
- 3.2.2. Remove the main power cable from inside of cabinet.
- 3.2.3. Fill oil reservoir with new, clean Mobile DTE-24 hydraulic fluid (or equal). Check oil sight gage for proper oil level.
- 3.2.4. Connect one of the exciter head 20 foot hoses to both the pressure out and return quick disconnects. This procedure effectively “short circuits” the output to the return and allows for all entrapped air in the pump to be removed on initial startup. Remove this connection after 5 to 10 minutes of running time.
- 3.2.5. Connect main power cable to main electrical service. The 1201B or 1301B Hydraulic Supply is wired for 230V, 60 Hz; 460V, 60 Hz or 380V, 50 Hz, 3 phase mains. The 3 phase wire colors are Red, Black and White. Ground (Green Wire) must be connected or ground loops will exist in instrumentation causing 60 Hz or 50 Hz signal noise.
- 3.2.6. Connect the 1104-MOD2 pump control cable (B-11921) to the hydraulic power supply and to the rear panel connector of the Master Controller.

- 3.2.7. Turn on the Main Power Switch (large red switch) located on the Hydraulic Power Supply.
- 3.2.8. Verify that the yellow *PHASE CORRECT* light is lit. If not, reverse the Red and Black wires at the main power connection. The pump will not start until the “phase correct” lamp is illuminated.

3.3. 1001P Field Test Power Supply Commissioning Procedure

- 3.3.1. Remove the covers from the front and rear of the unit.
- 3.3.2. Select either 115 VAC or 220 VAC with the *VOLTAGE SELECTOR* switch on the “Electrical Control Box #2” at the top, rear of the power supply. (See Drawing B-30064)
- 3.3.3. Connect the power cord to a 115 VAC (30 A service) or 220 VAC (15 A service) source. Be sure to connect the green wire to a solid ground lug.
- 3.3.4. The power supply front panel green light should be illuminated indicating that power has been applied.
- 3.3.5. Remove the cap fitting on the hydraulic reservoir fill hose and insert the hose in a 5 gallon container of Mobil DTE-24 or DTE-25 clean oil and set the ball valve located at the rear, bottom of the pump cabinet to the *FILL* position. (See Drawing B-30060 located at the end of the Field Test Power Supply Manual Section)
- 3.3.6. Turn on the *TRANSFER PUMP* switch located on the “Electrical Control Box #2” at the top, rear of the Power Supply. (See Drawing B-30064)
- 3.3.7. It will take approximately 5 minutes for the oil to reach the sight gage at the top of the reservoir. Be careful to NOT OVERFILL THE PUMP RESERVOIR! Fill to the top gradicule and turn off the *TRANSFER PUMP* switch.
- 3.3.8. Replace the fill hose cap fitting.
- 3.3.9. Connect the 1104-Mod4 pump control cable (B-11921) to the *CONTROLLER* connector of the power supply and the rear panel connector of the Master Controller.

3.4. Starting the Hydraulic Power Supply

- 3.4.1. Check to see that the Red *EMERGENCY STOP BUTTON* located on the Power Supply is pulled out. The unit will not start if this switch is pushed into its *STOP MODE*.
- 3.4.2. Push the Red *POWER* button on the Master Controller. It should light up along with the *PUMP STOP* light.
- 3.4.3. Push the *PUMP START* button on the Master Controller and the Power Supply should start up. The *GREEN* voltage applied light should be illuminated at this time. (Pump pressure will be *ZERO* due to the short circuit hose). After 5 to 10 minutes, shut down the pump. **See 3.2.4.**
- 3.4.4. Remove the hose connecting the pressure out to the return. Restart the Power Supply. Allow approximately 10 to 30 seconds for the pump to come up to 3000 psi. Check the pressure on the gage located on the side of the Hydraulic Power Supply. It should read approximately 3000 to 3200 psi.
- 3.4.5. Verify that the fan motor located in the Hydraulic Power Supply is operating.
- 3.4.6. The 1001P or 1201B or 1301B Hydraulic Power Supply is now running correctly.
- 3.4.7. Push the *PUMP STOP* button. The power supply will shut down and the *PUMP STOP* switch will stay lit.
- 3.4.8. Push the *POWER* switch of the Master Controller to turn it off.

3.5. Hydraulic Hookup

- 3.5.1. Connect the Hydraulic Power Supply pressure and return hoses to the Exciter Head pressure and *Return* hoses via the polarized quick disconnects supplied with the system hoses.
- 3.5.2. Take care to maintain cleanliness by always attaching caps to the quick disconnects when disconnected.

3.5.3. When in doubt about hose polarity, the convention is:

Supply Pressure - Coupler
Supply Return - Nipple

3.5.4. Take care that hoses will not rub against sharp objects when pulsating.

3.6. Cable Hookup

3.6.1. Connect cable C-11226 to the Master Controller rear panel connector and to the servovalve and load cell of the Exciter Head.

3.6.2. Connect cable B-11689 to the rear panel connector of the Master Controller and the displacement connector of the Exciter Head.

4. Operation Procedure

4.1. Switch Settings

4.1.1. Set the switches on the back of the Master Controller to the following:

CONTROLLED VARIABLE

STATIC

EXTERNAL

(Static Displacement
Control)

INTERNAL

(Static Force Control)

DYNAMIC

INTERNAL

STATIC PRELOAD

COMPRESSION

POWER AMP

INT

- 4.1.2. Set the switches on the front of the Master Controller to the following:

DITHER	OFF
STATIC SET POINT	0.0
STATIC GAIN	VARIABLE (For Displacement Control) FIXED (For Force Control)
VARIABLE GAIN	5.0
LOAD CELL	OPERATE
EXCITATION MODE	STANDBY/ RESET
FREQUENCY	HIGH
DYNAMIC SETPOINT	0.0

- 4.1.3. Connect a 1.0 Vrms variable frequency oscillator to the Program Input J308. (1 Hz to 2000 Hz)
- 4.1.4. Press *POWER* on Master Controller. The *POWER* light will be illuminated.
- 4.1.5. Press *PUMP START* on the Master Controller.
- 4.1.6. Turn the *EXCITATION MODE* to *STATIC*. The *STATIC SIGNAL LEVEL* should remain at 0% since the *STATIC SETPOINT* is set to 0.0. Turn the *STATIC SETPOINT* to the position desired of the piston (or static force level if in *FORCE CONTROL MODE*).
- 4.1.7. Turn *EXCITATION MODE* to *STATIC + DYNAMIC*.
- 4.1.8. Slowly increase the *DYNAMIC SETPOINT* until the desired force is monitored at the *DYNAMIC SIGNAL LEVEL* meter and is measured at the *LOAD CELL OUTPUT BNC*. The output voltage is calibrated at 250 lb/ volt.

5. Shutdown Procedures

- 5.1. Turn *EXCITATION MODE* to *STANDBY/ RESET*.
- 5.2. Push *PUMP STOP* of the Master Controller.

6. Troubleshooting Guide

Problem	Action
Static meter does not indicate piston is retracted when system is turned on in Standby/ Reset mode. OR Static meter does not show changes in displacement or force when the set point is changed.	Check that the hydraulic power supply is turned on and reading 3000 psi. See 3.4. Check that all hoses and cables are connected. See 3.5. and 3.6. Verify that all Master Controller switches are in the correct position. See 4.1.1. and 4.1.2.
No force is measured at the Force Output BNC or is indicated on the Dynamic meter when the system is in the Static + Dynamic Mode.	Verify that the 1 V rms signal from the signal source is connected to the Program Input BNC on the back of the Master Controller. See 4.1.3. Verify that the Dynamic Set Point potentiometer is turned up. See 4.1.8.

7. Storage Instructions

Be sure to attach the caps and plugs to all hydraulic quick disconnects to protect from contamination when not in use.

Keep the system in a clean and low humidity environment when not in use.

1100, 1200 & 1300 Exciter Heads



1. Introduction

The linear single-ended exciter head is a high-force, wide frequency response, linear actuator designed to be used in a closed loop control system. It is ideally suited for mechanical impedance and component testing. Using the latest design concepts in force transducers and servovalves has resulted in a compact Exciter Head that is suited to simulate the level and direction of input forces encountered in complex machinery. A load cell provides a force feedback signal for monitoring and closed loop force control of the actuator. A tandem mounted displacement kit provides a feedback signal for closed loop displacement control of the exciter.

The Displacement Kit is designed to provide a displacement feedback signal for an exciter head. When used with the MOD4 version of the Xcite Master Controller, the Displacement Kit provides a means of monitoring or controlling low-frequency displacements. Also, the kit may be used to maintain a static or mean position while controlling another dynamic variable, such as force, velocity, or acceleration. The Kit is constructed such that it becomes an integral part of the exciter head. It is mounted along-side of the actuator to maintain the small total package size.

The Exciter Head, supplied with all necessary electrical and hydraulic connectors, is designed so that wrong connections cannot be made. Also included on all standard exciter heads is a miniaturized strain-gauge force transducer that permits continuous monitoring of static and dynamic forces.

Use the following table to determine the force capacity for your model.

Model	1106	1107	1206	1207	1207A	1352	1306
Static Force (lbs)	1000	1000	2000	2000	4000	5000	20,000
Dynamic Force (lbs)	1000	1000	2000	2000	2000	5000	20,000

WARNING

Precautions regarding the test specimen should be considered.

Although exciter heads are rated for static plus a peak dynamic force, exciter heads are capable of compressive forces in excess of 200% of their rating, and tensile forces in excess of 100% of that rating if instability in the control loop occurs.

2. Theory of Operation

2.1. Introduction

The major function of the exciter head is to apply a controlled static force preload and a controlled random or sinusoidally varying dynamic force (variable frequency), to a test structure. The cylinder rod is the actual output device. The force transducer and servovalve control this output. The load cell provides an output signal proportional to static loads, but unlike a piezo-electric transducer, operates from DC to 1500 Hz. Thus, the cell is well suited to provide a constant monitor of the exciter's preload for use in the control circuitry. The load cell provides a signal proportional to time-varying forces (dynamic) and therefore provides complete signal information on the output force.

The servovalve is supplied a constant source of pressure (3000 psi) which is applied to either side of the exciter's cylinder in a differential manner. The driving signal to the servovalve is provided by the system controller.

2.2. Circuit Description (Electric)

2.2.1. Head

The load cell and servovalve are separately connected to their respective cable connectors. Shielded cable is used throughout to provide optimum reduction of externally induced noise voltage.

2.2.2. Displacement Kit

All connections to the Displacement Kit are through a single connector mounted in the Displacement Kit cover. Pins A and B of this connector are +15 VDC and ground respectively. These bring power from the Controller to the LVDT. On selected models, a filtering capacitor (68 mfd) across these pins is used to reduce noise generated by the LVDT from getting back to the controller circuitry. Pins C and D are the displacement feedback signal leads to the Controller.

2.3. Circuit Description (Hydraulic)

2.3.1. Head

Oil is supplied to the exciter head at 3000 psi by the hydraulic power supply. The servovalve controls the flow of oil into the cylinder ports, creating a differential pressure according to the force demands of the control system. Oil from the servovalve is routed back to the hydraulic supply.

2.3.2. Displacement Kit

The Displacement Kit consists of an Exciter Head top plate, an LVDT-type displacement transducer, and a cover with electrical connector. The top plate contains a means for clamping the LVDT and a self lubricating bronze impregnated bushing which prevents side loading of the LVDT core. The displacement transducer is an integrated package consisting of a solid-state oscillator, and a phase-sensitive demodulator. The coils of the transformer are connected in series opposition so that output resulting from a displacement is a DC voltage proportional to the core position with respect to the electrical center. The polarity of the voltage is a function of the direction of the core displacement with respect to the electrical center.

3. Major Components**3.1. Actuator**

The hydraulic actuator consists of a cylinder, a single ended piston, a specially designed bearing to minimize oil leakage and increase seal life, and a manifold for routing the oil from the external supply hoses to the servovalve and hydraulic cylinder. The built-in oil routing from external hoses to the servovalve is designed for safety and to meet the response and force requirements of the system. Cylinder specifications for Xcite heads discussed in this manual are in the following table.

Model	1106	1107	1206	1207	1207A	1352	1306
Bore	1"	1"	1.5"	1.5"	2"	1.75"	5"
Stroke	1"	2"	1"	2"	2"	3"	1"

3.2. Servovalve

The servovalve is a dual-stage flow-control device using electromagnetic drive in the first stage to control the hydraulically amplified second stage. This second stage provides the differential pressure flow to control the piston. Hydraulic fluid entering the valve must be filtered to 3 micron absolute to prevent damage to the servovalve. The unit is NOT customer-serviceable.

3.3. Load Cell

The load cell is a force transducer which incorporates a 350 ohm 4-leg strain gage. By applying a voltage across the strain-gage bridge, a differential voltage proportional to force is developed at the bridge output. The load cell excitation voltage is provided by a precision voltage reference in the Master Controller.

The Load Cell may be used for testing in tension, compression, or a combination of both. The cell is sized so that the maximum load of the exciter head cannot damage the unit.

Calibration is performed by simulating bridge unbalance with a known value of resistance. The excitation voltage of the bridge is then adjusted to obtain the force value stated on the load cell resistor calibration plug. The Calibration Plug, showing the calibration value unique to the load cell used in your unit, is included with the system. The "Cal Plug" is inserted in its appropriate receptical located on the rear of the Master Controller.

3.4. Displacement Transducer Kit

The Displacement Kit consist of a Linear Variable Displacement Transducer (LVDT) and the hardware necessary to mount it to the exciter head.

The LVDT is a sealed assembly which contains all necessary solid-state electronics required to develop a voltage proportional to the stroke of the piston. The unit consists of a stationary coil assembly which is clamped to the cylinder and a core (rod) which is attached to the piston. An oil impregnated bronze bushing prevents the piston from turning and causing misalignment in the core/coil assemblies.

The core position is adjusted so that the LVDT output is equal and of opposite polarity at the extreme limits of piston position. A voltage null represents mid-stroke of the piston. The output is nominally +/- 12 VDC for an input of 15 VDC which is supplied by the Master Controller via the displacement cable. Internal amplifiers in the Master Controller convert the +/- 12 VDC signal from the LVDT to 0 to +10 VDC for monitoring of the displacement signal. Calibration is such that +10 volt output always equals the overall stroke of the exciter head. For example, a 2" stroke exciter head will have an output sensitivity of 2 in/ 10V or .2 in/ Volt.

4. Operation

All operations of the Exciter Head are controlled by the appropriate Xcite Controller. Please refer to the Master Controller section in this manual for proper use of the system.

WARNING

Before performing any test, check the mounting of the load cell to the actuator. The load cell must be firmly mounted to the actuator or fatigue failure of the actuator mounting stud may occur.

4.1. Operating Precautions

- 4.1.1.** Unless the Load Cell is attached to the test specimen, the peak dynamic force should not exceed the static force. This can cause the Load Cell to pull away from the test piece every half cycle, and impact or hammer the test piece on the other half cycle. Damage inflicted on the load cell in this manner is not covered under any Xcite warranty.
- 4.1.2.** If the feedback signal is broken or the controller malfunctions, the exciter can output full force. Since the servovalve functions as a differential device, the full 3000 psi applied to the bottom side of the piston will produce in excess 100% of the rated forces.
- 4.1.3.** Proper selection of feedback signal can improve exciter performance and provide data with greater dynamic range.

EXAMPLE:

A vibration test is to be performed on a test specimen requiring static preload that must be held as accurately as possible to 5000 pounds. The test specimen has a static stiffness (k) of 20,000 pounds per inch. Should the static loop of the controller use force feedback or displacement feedback? Consider the following:

The usable range of most control loops is approximately 40 dB (ratio of 100:1). An exciter with a one inch stroke and 58,000 pound total force capability used to perform this test would result in displacement control down to .01 inch or force control down to 580 pounds.

Therefore, if force is used to control the static loop, accuracy should be easily held to 5,000 pounds, +/-580 pounds.

However, if displacement is used to control the static loop, accuracy could be held to .01 inch. With a static stiffness of 2×10^4 lbs/ in, this would result in force control accuracy of 5,000 pounds, +/-200 pounds (.01 inch x 2×10^4 lbs/ in = 200 pounds).

In conclusion, it is very important that you understand how to operate the system and make proper decisions on test methods to be used.

5. Care and Maintenance

Maintenance is minimal. Precautions for cleanliness are the major considerations.

5.1. Each Usage

End/ Dust covers should always be kept on the Exciter Head hoses when they are not connected because contaminants larger than 3 micron can damage the servovalve.

The top plate should always be kept clean to prevent piston scouring. Additionally, dirt on the top plate will affect the LVDT.

5.2. Each Month

Place a few drops of any lubrication oil on the linear guide bearing for the Displacement Transducer.

5.3. Periodic

Periodically replace the piston rod seals. These can be expected to last a minimum of 100 hours of operation and longer if side load is kept at a minimum. When leakage from the top of the exciter head becomes excessive, the seals should be replaced by returning the Exciter Head to the factory.

6. Specifications

Output Response

The force output is both a function of frequency, and test specimen stiffness.
(See enclosed Response curve)

Model	1106	1107	1206	1207	1207A	1352	1306
Dimensions							
Height	6.12"	7.12"	9.75"	10.75"	10.75"	23"	20.5"
Width	5.87"	5.87"	7.87"	7.87"	9.62"	14"	13"
Depth	3.75"	3.75"	4.18"	4.18"	5.13"	12"	10"
Stroke (Peak to Peak) ¹	2"	2"	1"	2"	2"	3"	1"
Displacement Kit	MT-302	MT-303	MT-302	MT-303	MT-303	MT-305	MT-302

Displacement Kit Model Number	MT-302	MT-303	MT-305
Displacement Transducer			
LVDT rated linear range	+/- .5"	+/- 1"	+/- 1.5"
LVDT maximum usable range	+/- .75"	+/- 1.5"	+/- 2.0"
Input (fixed by controller)	+15 VDC	+15 VDC	+15 VDC
Output	0-10 VDC	0-10 VDC	0-10 VDC
Frequency Response (3 dB point)	110 Hz	100 Hz	75 Hz
Linearity	+/- .5% of full scale output at rated linear range (deviation from best straight line passing through 0)		

	Xcite 1100-4 System	Xcite 1100-6 System	Xcite 1100-7 System
Hydraulic Power Supply	1201B 5 GPM (20 l/m)	1201B 5 GPM (20 l/m)	1201B 5 GPM (20 l/m)
Master Controller	1104-Mod4	1104-Mod4	1104-Mod4
Exciter Head	1106-4-T/C	1107-4-T/C	1114-4-T/C
Static Force	1,000 lb (4,450 N)	1,000 lb (4,450 N)	Total Static & Dynamic Force = 1,000 lb (4,450 N)
Dynamic Force	1,000 lb (4,450 N)	1,000 lb (4,450 N)	
Stroke	1.0 in (25 mm)	2.0 in (50 mm)	1.0 in (25 mm)
Rod	.75 in (18 mm)	.75 in (18 mm)	.75 in (18 mm)
Bore	1.0 in (25 mm)	1.0 in (25 mm)	1.0 in (25 mm)
Thread	.38 - 24	.38-24	.38-24
Load Cell	2,500 lb (11,125 N)	2,500 lb (11,125 N)	2,500 lb (11,125 N)
LVDT	1.0 in (25 mm)	2.0 in (50 mm)	1.0 in (25 mm)
Exciter Design	Single Ended	Single Ended	Double Ended

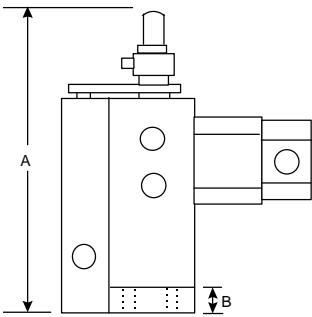
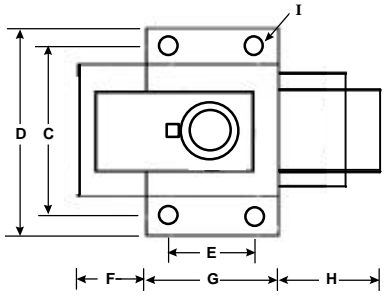
Exciter Head	A		B		C		D		E		F		G		H (dia)		I (dia)	
	in	mm	in	mm	in	mm	in	mm	in	mm	in	mm	in	mm	in	mm	in	mm
1106-4-T/C	6.12	153	0.60	15	3.12	78	3.75	94	1.38	35	1.12	28	2.00	50	2.75	69	0.28	7
1107-4-T/C	7.12	178	0.60	15	3.12	78	3.75	94	1.38	35	1.12	28	2.00	50	2.75	69	0.28	7
1114-4-T/C	8.78	220	0.60	15	3.12	78	3.75	94	1.38	35	1.12	28	2.00	50	2.75	69	0.28	7

Xcite 1100-4 Laboratory System

Peak Dynamic Force vs. Frequency

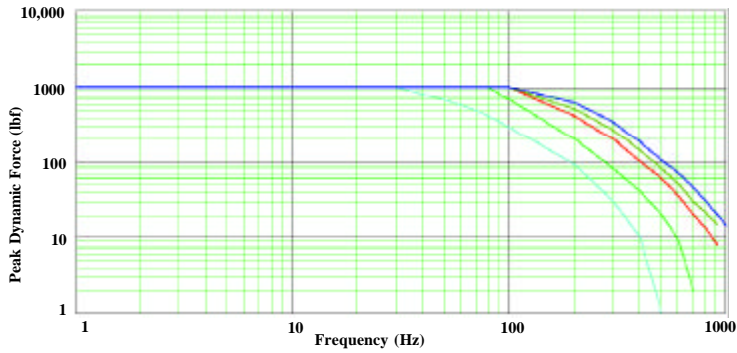

Peak Displacement vs. Frequency

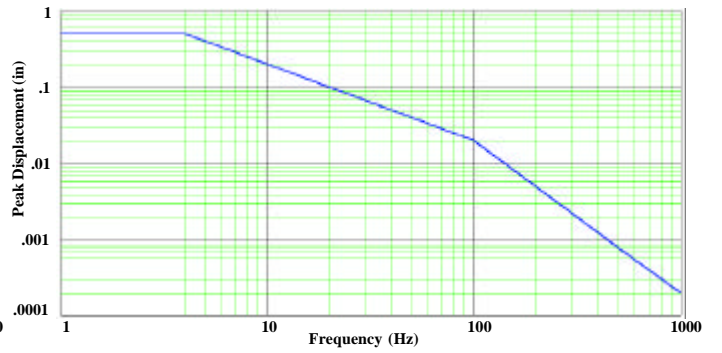

Structure Stiffness:

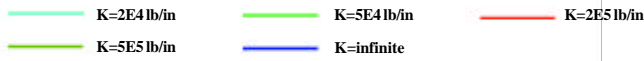

Xcite 1100-6 Laboratory System

Peak Dynamic Force vs. Frequency

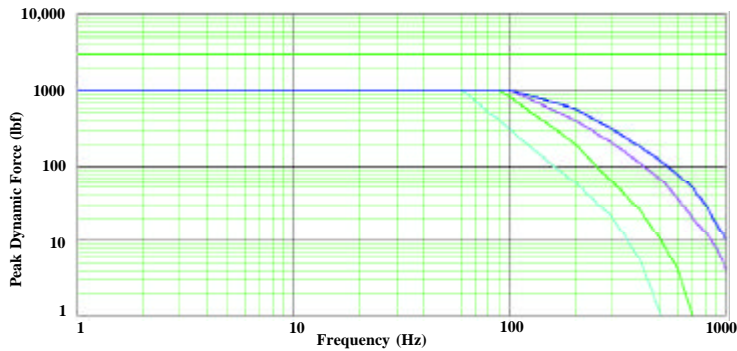

Peak Displacement vs. Frequency

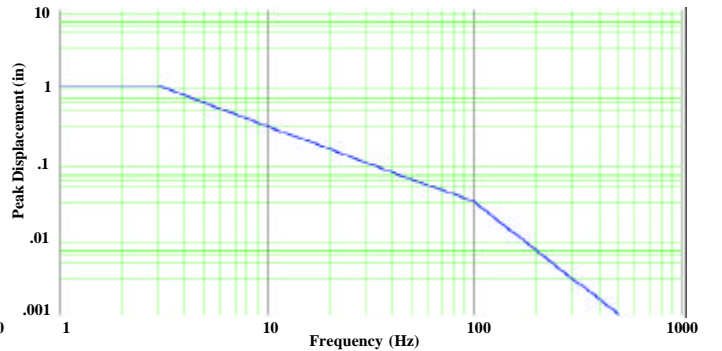

Structure Stiffness:



Xcite 1100-7 Laboratory System

Peak Dynamic Force vs. Frequency

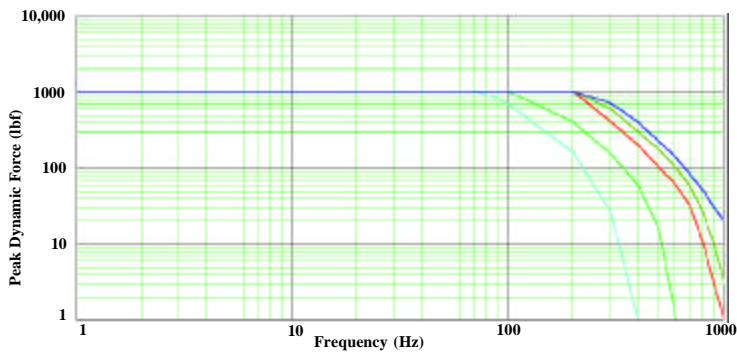

Peak Displacement vs. Frequency

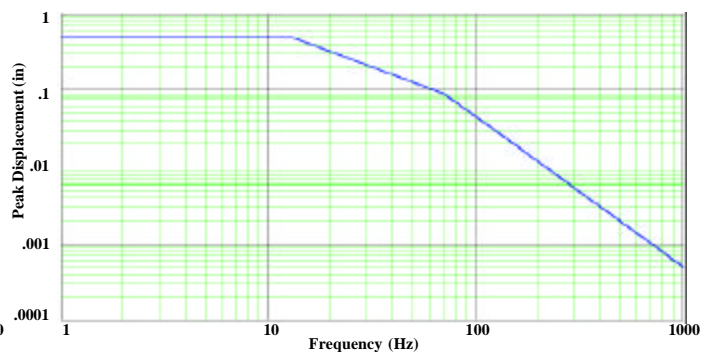

Structure Stiffness:

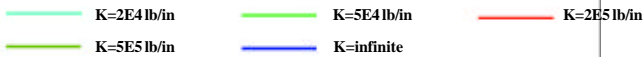



CERTIFICATE OF CALIBRATION

Transducer Model: 2522
Serial Number: 2055
Capacity: 2500 LBS
Calibration Date: 3/28/02
Excitation: 10 VDC
Input Resistance: 357 Ohms
Output Resistance: 355 Ohms
Temperature Range: 50-150 Degrees F

Applied Load in LBS	Compression MV/V
0	0.0000
500	0.2179
1000	0.4335
1500	0.6500
2000	0.8656
2500	1.0813
0	0.0002

An output of **0.2876 MV/V** is induced when a shunt resistor of 301K ohms is applied across (-) Excitation and (-) Signal.

Notes: 301K ohms induces an output of 0.2876 MV/V which is equivalent to 664.9 lbs of force.

Wiring Code: RED (+)Excitation A
 BLACK (-) Excitation B
 GR/YEL (+)Signal C
 WHITE (-) Signal D

This is to certify that the following instrument was calibrated using loading equipment traceable to NIST through one or more of standards. The unit was found to meet or exceed all published sales literature accuracy specifications.

Approved by: _____



CERTIFICATE OF CALIBRATION

Transducer Model: 2522
Serial Number: 2056
Capacity: 2500 LBS
Calibration Date: 5/16/02
Excitation: 10 VDC
Input Resistance: 354 Ohms
Output Resistance: 355 Ohms
Temperature Range: 50-150 Degrees F

Applied Load in LBS	Compression MV/V
0	0.0000
500	0.2100
1000	0.4216
1500	0.6331
2000	0.8445
2500	1.0549
0	0.0001

An output of 0.2963 MV/V is induced when a shunt resistor of 301K ohms is applied across (-) Excitation and (-) Signal.

Notes: 301K ohms induces an output of 0.2963 MV/V which is equivalent to 702.2 lbs of force.

Wiring Code: RED (+)Excitation A
 BLACK (-) Excitation B
 GR/YEL (+)Signal C
 WHITE (-) Signal D

This is to certify that the following instrument was calibrated using loading equipment traceable to NIST through one or more of standards. The unit was found to meet or exceed all published sales literature accuracy specifications.

Approved by: _____

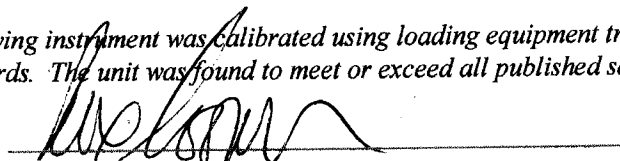

1201B Hydraulic Power Supply



1. Introduction

The XCITE Hydraulic Power Supplies are designed to fulfill the power requirements of exciter heads using the most energy-efficient and maintenance free components available. All units use a highly reliable, variable volume, pressure compensated, axial-piston pump to deliver only the energy demanded by the load, thus reducing power consumption.

2. Commissioning Procedure**2.1. Initial Setup of Hydraulic Power Supply is as follows:**

- 2.1.1.** Remove all packing material from inside and outside the pump cabinet.
- 2.1.2.** Remove the main power cable from inside of cabinet.
- 2.1.3.** Fill oil reservoir with 20 gallons of new, clean Mobile DTE-24 hydraulic fluid (or equal) (See drawing B-30251, item 3 for location of filler cap). Check oil sight gage for proper oil level.
- 2.1.4.** Connect one of the exciter head 20 foot hoses to both the pressure out and return quick disconnects. This procedure effectively "short circuits" the output to the return and allows for all entrapped air in the pump to be removed on initial startup. Remove this connection after 5 to 10 minutes of running time.
- 2.1.5.** Connect main power cable to main electrical service. The 1201B Hydraulic Power Supply is wired for 380V, 50Hz 3-phase mains. The 3-phase wire colors are Red, Black and White. Ground (Green Wire) must be connected or ground loops will exist in instrumentation causing 60Hz or 50Hz signal noise.
- 2.1.6.** Connect the 1104-MOD2 pump control cable (B-11921) to the Hydraulic Power Supply and to the rear panel connector of the Master Controller.
- 2.1.7.** Turn on the Main Power Switch (large red switch) located on the Hydraulic Power Supply.

- 2.1.8.** Verify that the yellow *PHASE CORRECT* light is lit. If not, reverse the Red and Black wires at the main power connection. The pump will not start until the *PHASE CORRECT* lamp is illuminated.

2.2. Starting the Hydraulic Power Supply

- 2.2.1.** Check to see that the Red *EMERGENCY STOP BUTTON* located on the Power Supply is pulled out. The unit will not start if this switch is pushed into its *STOP MODE*.
- 2.2.2.** Push the Red *POWER* button on the Master Controller. It should light up along with the *PUMP STOP* light.
- 2.2.3.** Push the *PUMP START* button on the Master Controller and the Power Supply should start up. The *GREEN* voltage applied light should be illuminated at this time. (Pump pressure will be *ZERO* due to the short circuit hose). After 5 to 10 minutes, shut down the pump. **See 2.1.4.**
- 2.2.4.** Remove the hose connecting the pressure out to the return. Restart the Power Supply. Allow approximately 30 seconds for the pump to prime and come up to 3000 psi. Check the pressure on the gage located on the side of the Hydraulic Power Supply. It should read approximately 3000 psi.
- 2.2.5.** Verify that the fan motor located in the Hydraulic Power Supply is operating.
- 2.2.6.** The 1201B Hydraulic Power Supply is now running correctly.
- 2.2.7.** Push the *PUMP STOP* button. The Power Supply will shut down and the *PUMP STOP* switch will stay lit.
- 2.2.8.** Push the *POWER* switch of the Master Controller to turn it off.

2.3. Hydraulic Hookup

- 2.3.1.** Connect the Hydraulic Power Supply pressure and return hoses to the Exciter Head pressure and *RETURN* hoses via the polarized quick disconnects supplied with the system hoses.
- 2.3.2.** Take care to maintain cleanliness by always attaching caps to the quick disconnects when disconnected.

2.3.3. When in doubt about hose polarity, the convention is:

Supply Pressure - Coupler
Supply Return - Nipple

2.3.4. Take care that hoses will not rub against sharp objects when pulsating.

2.4. Cable Hookup

2.4.1. Connect cable C-11226 to the Master Controller rear panel connector and to the servovalve and load cell of the Exciter Head.

2.4.2. Connect cable B-11689 to the rear panel connector of the Master Controller and the displacement connector of the Exciter Head.

3. Theory of Operation

The purpose of the XCITE Hydraulic Power Supply is to supply clean hydraulic oil at a constant pressure under the varying flow demands of the force exciter head. The system was designed to do this in the most efficient manner, considering power requirements, reliability, safety, ease of maintenance, and operator convenience.

3.1. Circuit Description (Hydraulic)

An oil reservoir provides storage for all necessary supply oil and provides some oil cooling. (See Drawing B-30251 and B-30252) Mounted on the reservoir are oil level and oil temperature gauges, a temperature sensitive switch, and a reservoir fluid level detector switch for motor shut down. A 3000 psi pressure is achieved by a variable volume, pressure-compensated pump that has a factory set delivery rate.

Fluid from the pump first passes through a three-micron (absolute) filter. Should this filter become clogged, a pressure drop builds up across the sensor, causing a switch to trip. This causes the *FILTER* light to illuminate. The system should not be operated until the filter element is changed. After passing through the filter, oil flows to the pressure output disconnect.

3.2. Circuit Description (Electric)

The electrical input is 380V, 50Hz, 3 phase (See drawing B-30253). The fourth wire (green) is a ground wire and must be tied to earth ground to prevent floating grounds due to an unbalanced load.

The pump motor uses the high voltage 3-phase power, while the remaining loads derive 120 volt, single-phase from the step-down Transformer T-1 (designated 14), appropriately connected to the incoming power to provide 120 VAC on the secondary of the transformer.

Two-way protection of the three-phase power is provided. A magnetic circuit protector provides over current protection. It is also connected to the electrical box operating handle to disconnect power in the electrical box.

Pump motor overload protection is provided by thermal overload heaters in the motor starter, which were specifically designed for the pump motor. A *RESET* button is conveniently located inside the electrical box, should be thermal overload trip. The pump start relay, 1CR, (designated 5), is a latch-up design so that momentary switches may be used for pump start and pump stop operations.

A phase sequence relay 1PM (designated 1) is connected to and monitors the 3-phase incoming line to determine if the phasing is connected correctly to provide proper motor rotation. If the *START* light is off, any two legs of the incoming lines should be reversed.

If the phase is incorrect, 1PM (1) remains de-energized, thus preventing the system from being energized. If the phasing is correct, 1PM (1) energizes, allowing 120 VAC from T-1 (14) to be applied to the pump unit.

The T-1 (14) Transformer is fused by 4FU and 5FU. The system *POWER* switch connects power to the control circuits. If oil temperature is normal, relay 2CR (designated 10) is not energized. Momentarily, pressing the *START* button will energize 1CR (designated 5) if oil level, temperature, filter, and pressure selection are correct.

Relay 1CR (5) energizes the motor starter 1M. Auxiliary contact 1M closes, latching 1CR. A normally closed CR1(5) contact opens, turning off the *STOP* light.

Momentarily pressing the *STOP* button breaks the latch-up circuit and de-energize 1CR (5) and the pressure relief solenoid. After a short delay, an *OFFDELAY* contact on 1CR opens, de-energizing the motor-starter coil and causing the pump to stop.

Relay 3CR (designated 10) is normally not energized unless the oil level drops. If the *RED OIL LEVEL LOW* light illuminates, the system must be reset by pushing the *STOP BUTTON* on the Master Controller and oil must be added to the reservoir. When a low oil level is detected, the pump is turned off.

Relay 2CR (10) is normally not energized unless the oil temperature exceeds 160 degrees F. If the *RED OIL OVERTEMP* is illuminated, the system must be reset by pushing the pump *STOP BUTTON* on the Master Controller after the system cools down.

If the differential pressure drop across the filter exceeds approximately 50 psi, the *RED FILTER* restriction light will illuminate. The Power Supply will **NOT** shut off, however the filter should be changed when the filter light is illuminated.

4. Description

Included on the hydraulic power supply are an oil supply line pressure gauge and a timer which records pump running time. Mounted on the side of the reservoir is an oil level sight gauge with an integral oil temperature thermometer. A reservoir drain is also located on the reservoir. All motor controls and associated electrical equipment are located in the electrical control box. Connections for pressure and return hoses are attached with quick disconnect style connectors.

4.1. Major Components

- Oil Reservoir
- Motor
- Variable volume pressure-compensated Pump
- Three-micron Filter Assembly
- Heat Exchanger
- Motor Control Box
- Hydraulic Hoses

4.2. Control Components

4.2.1. Emergency Stop Switch

This switch de-energizes the motor-starter relay, bypassing all shutdown logic; thus causing the motor to stop. Use it only in an emergency situation.

WARNING

Some operating conditions cause the system to shutdown.

4.3. Monitoring Devices

4.3.1. Phase Sequence Relay (PHASE Indicator)

A phase sequence relay monitors the 3-phase power applied to the unit. If the phasing of the wires is incorrect, the relay will prevent the pump from being energized, and the *PHASE CORRECT* lamp will not illuminate.

4.3.2. Filter Pressure Drop Sensor (FILTER Indicator)

This sensor sends a signal if the differential pressure across the filter element is excessive. This occurs when the differential pressure drop across the replaceable filter element exceeds 50 psi. Excessive differential pressure occurs when the filter element is clogging, fluid viscosity is too high, fluid temperature is too low, or any combination. At that time, the *FILTER* light illuminates.

Note: There may be times when the system is first started and the oil is cold that the filter light will illuminate. Allow 10 to 20 minutes of operation and if the filter light goes off, then the filter is not dirty and does not need replaced.

4.3.3. OIL OVERTEMP Indicator

The temperature sensor monitors the oil temperature of the reservoir and prevents the pump from running if the oil temperature exceeds 160 degrees F. The *OIL OVERTEMP* light illuminates, indicating that the maximum allowable oil temperature has been exceeded.

4.3.4. LOW OIL Indicator

The level sensor monitors the oil level in the oil reservoir and prevents the pump from running if the oil level is low. The pump will shut down or fail to start until additional oil is added. The red *LOW OIL* indicator lamp illuminates during this condition.

4.3.5. Voltage Applied Indicator

A green light indicating power is switched onto the pump motor. The light will ONLY illuminate after depressing the *PUMP START* button on the Master Controller.

5. Care and Maintenance**WARNING**

Electrocution or severe electrical shock may occur.

When the MAIN power is plugged in, the line side of the motor starter is at line voltage.

The XCITE Hydraulic Power Supply was designed so that no periodic lubrication on mechanical parts is required. Cleanliness is very important when using sophisticated hydraulic systems, and although a clean room environment is far from necessary, general cleanliness is recommended. Routine maintenance on the overall system should include the following.

5.1. Operating Care

- 5.1.1.** Wipe off all cables after each use.
- 5.1.2.** Never drag cables across the floor.
- 5.1.3.** Immediately after the hydraulic hoses are disconnected, cover all hydraulic connectors with the covers provided.
- 5.1.4.** During operation, the oil temperature should never rise above 160 degrees F. (The oil temperature thermal relay shuts down the system at 160 degrees F.)
- 5.1.5.** Before each test, check the oil pressure to make sure it is at 3000 psi. A flow screw adjustment is located on the top of the pump compensator assembly. This control is preset at the factory and should not be adjusted (slotted screw with locknut).
- 5.1.6.** Before each test, check to make sure that the air heat exchanger blower is operational, that pump maintenance warning lights are not illuminated, and that the phase sequence indicator show proper motor phasing.

If for some reason the system has overloaded, the pump motor started thermal overload will trip. Reset it by opening the access door, and pushing the reset button located on the motor starter.

5.2. Maintenance

- 5.2.1.** To keep the system operating within the specified limits, it is necessary to periodically check the oil level by observing the oil level gauge. Fluid should fill the gauge.
- 5.2.2.** Oil should be changed after every 1000 hours of pump operation.

- 5.2.3.** The condition of the filter is displayed by the light on the electrical control box inside the cabinet. The filter requires replacement only when the *FILTER* light is illuminated.

WARNING

All oil should be completely drained from the reservoir during transportation. (See drawing B-30251, item 31 for location of reservoir drain hose)

6. Troubleshooting

Listed below are some of the common problems which may be experienced with a Power Supply.

6.1. Unit Overheats

Overheating may be caused by a clogged heat exchanger, restricted air flow, malfunction of the check valves, or failure of the heat exchanger fan.

The efficiency of an oil/ air heat exchanger decreases as the ambient temperature increases. The maximum ambient temperature at which the heat exchange can effectively maintain the oil temperature below 160 degrees F is approximately 100 degrees F. If continuous operation in ambient temperature above 100 degrees F is desired, it is recommended that an oil/ water heat exchanger be added externally to cool the return line oil before it is returned to the oil reservoir.

6.2. Pump de-energizes

The pump de-energizing for no apparent reason can be caused by a noisy 3-phase power line where the 3-phase voltage drops below the rated voltage for more than 10 milliseconds. This results in the phase monitor relay 1PM momentarily de-energizing, shutting off the system.

7. Specifications

<u>Item</u>	<u>Specifications</u>
Dimensions	
Height	54.25"
Width	38.00"
Depth	30.13"
Weight	863 lb (without oil)
Hydraulic Oil	20 gallons of Mobil DTE-24
Pump	5 GPM @ 2800 psi
Pressure-compensated variable flow axial piston	
Motor, 380V, 50Hz	10 HP
Reservoir	20 gallon
Cooling	Air (Maximum ambient room temperature 100 degrees F)

8. Drawings***Model 1201B***

Outline Dimensions	B-30250
Pump/ Reservoir	B-30251
Hydraulic Schematic	B-30252
Electrical Schematic	B-30253
Electrical Box Layout	B-30254

1 2 3 4 5 6 7 8 9 10 11 12 13 14 15 16 17

ITEM	QTY.	MFG.	MODEL NUMBER	DESCRIPTION
------	------	------	--------------	-------------

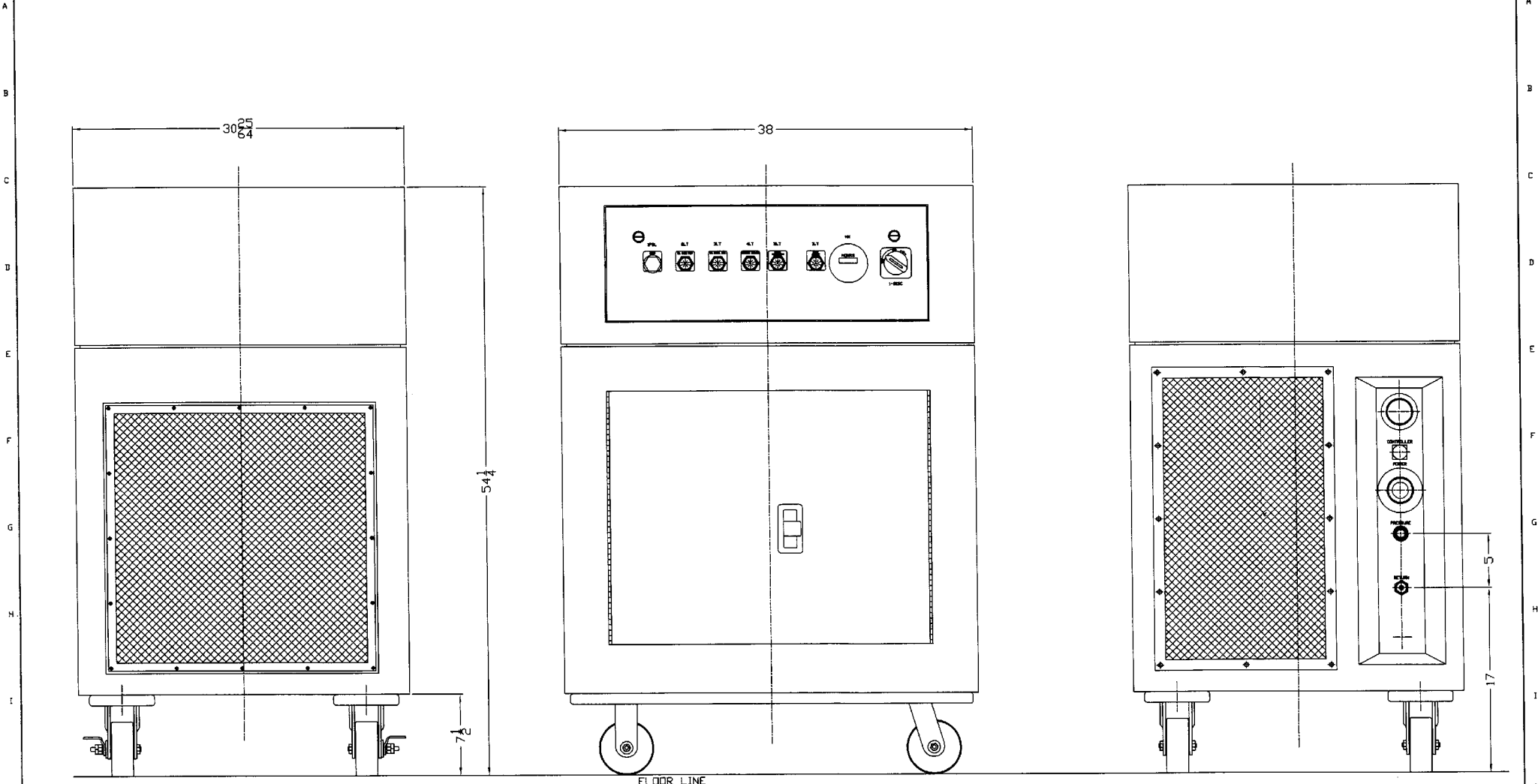

ITEM ID #ESD-120-00134-06-09

DWG# D-12492-R00-S01

NO.	DATE	BY	ZONE	CHANGE DESCRIPTION	NO.	DATE	BY	ZONE	CHANGE DESCRIPTION

CONFIDENTIAL DOCUMENT, PROPRIETARY INFORMATION NOT TO BE DISCLOSED TO OTHERS WITHOUT THE EXPRESS WRITTEN CONSENT OF TRIAD FLUID POWER INC. THIS DOCUMENT AND OTHER INFORMATION FROM TRIAD FLUID POWER INC. PROVIDE PRODUCT AND/OR SYSTEM OPTIONS FOR FUTURE INVESTIGATION BY USERS HAVING TECHNICAL EXPERTISE. BEFORE YOU SELECT OR USE ANY PRODUCT OR SYSTEM, IT IS IMPORTANT THAT YOU ANALYZE ALL ASPECTS OF YOUR APPLICATION AND REVIEW THE INFORMATION CONCERNING THE PRODUCT OR SYSTEM IN THE CURRENT PRODUCT CATALOGS AS TO THE VARIETY OF OPERATING CONDITIONS AND APPLICATIONS FOR THESE PRODUCTS OR SYSTEMS. THE USER, THROUGH ITS OWN ANALYSIS AND TESTING IS SOLELY RESPONSIBLE FOR MAKING THE FINAL SELECTION OF THE PRODUCTS AND SYSTEMS AND ASSURING THAT ALL PERFORMANCE, SAFETY AND WARNING REQUIREMENTS OF THE APPLICATION ARE MET.

<small>THIS DRAWING IS TO BE INTERPRETED USING THE LATEST REVISION OF ANSI/ASME Y14 DRAFTING STANDARDS.</small>	<small>TOLERANCES UNLESS OTHERWISE SPECIFIED</small> DECIMAL: .015 FRACTIONS: 1/32 ANGULAR: .1° BREAK SHARP CORNERS	JOB NO. 1002741 REF. NO. DATE 07-20-09 REF. PAGES	DRAWN BY JAS APPR. BY DATE SCALE 1/4	
	SERIAL NO. 2000	DRAWING NO. ESD093065-1	CUSTOMER XCITE	DRAWING NAME 12018 HYDRAULIC POWER SUPPLY-CABINET
	SHEET 1 OF 1	DRAWING NO. B-30250	CUSTOMER XCITE	DRAWING NAME 12018 HYDRAULIC POWER SUPPLY-CABINET
	AUTOCAD LT 2000	SERIAL NO.	CUSTOMER XCITE	DRAWING NAME 12018 HYDRAULIC POWER SUPPLY-CABINET

1 2 3 4 5 6 7 8 9 10 11 12 13 14 15 16 17

SYSTEM REQUIREMENTS	
RESERVOIR CAPACITY:	20 GALLONS
FLUID TYPE:	DTE25
SYSTEM OPERATING TEMPERATURE:	130°F
PUMP FLOW RATE:	5 GPM
SYSTEM OPERATING PRESSURE:	3000 PSI
PUMP COMPENSATING PRESSURE:	3000 PSI
RELIEF VALVE PRESSURE:	3300 PSI
PRESSURE SWITCH SETTING:	NA PSI
ELECTRIC MOTOR:	10 HP @ 1470 RPM
PAINT SPECIFICATION:	SEE ABOVE

NOTE: NOT ALL COMPONENTS ARE SHOWN FOR CLARITY

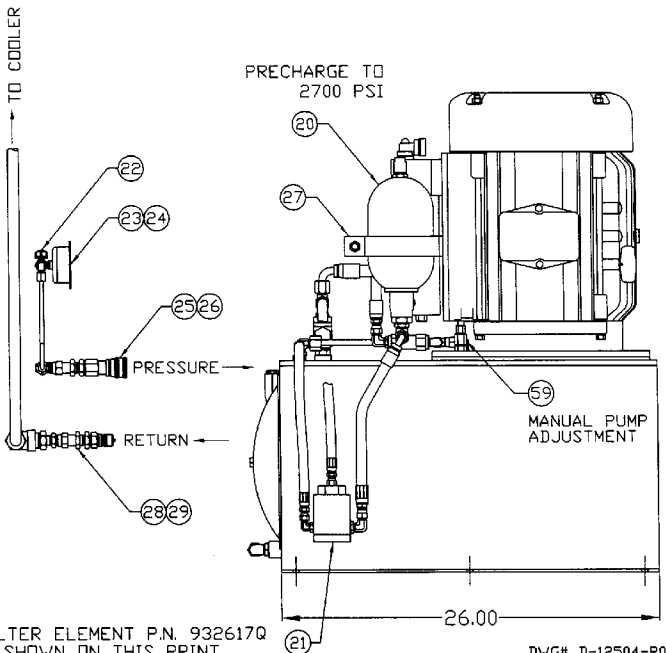
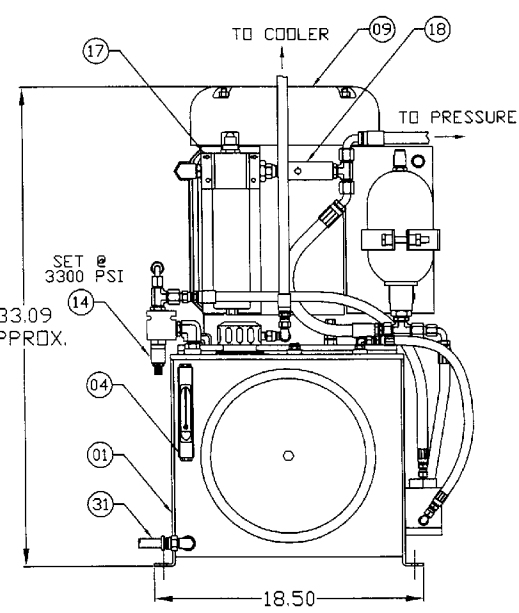
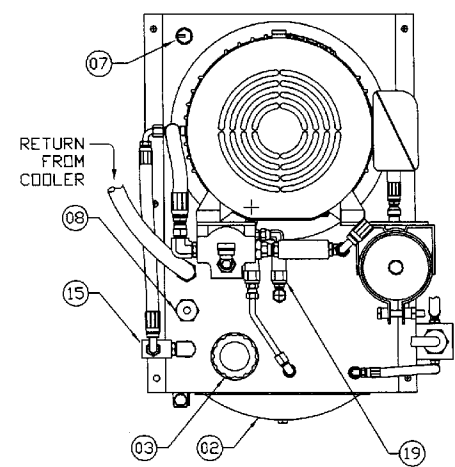

NOTE: REPLACEMENT FILTER ELEMENT P.N. 932617Q
 * DENOTES ITEMS NOT SHOWN ON THIS PRINT.

ITEM	QTY.	MFG.	MODEL NUMBER	DESCRIPTION
01	1	TFP	D-5594-A-01	RESERVOIR, 20 GALLON
02	1	HYDRD-CRAFT	HC-EC-12	COVER, RESERVOIR END
03	1	HYDRD-CRAFT	HC-120	BREATHER, FILLER
04	1	LUBE DEVICES	G1615-05-A-1	GAUGE, SIGHT LEVEL/TEMPERATURE
05	1	HYDRD-CRAFT	HA-FS-5	STRAINER, SUCTION
06	1	ALLEN BRADLEY	837-A4A	SWITCH, TEMPERATURE
07	1	ALLEN BRADLEY	837-N6	BULBVELL
08	1	GEMS	01701	SWITCH, LEVEL
09	1	LEESON	G150102.60	MOTOR, ELECTRIC 15/10 HP#1765/1470 RPM 254 FRAME,TEFC W/BASE
10	1	MAGNALDY	M370H6	INSERT, COUPLING
11	1	BSF	1102-320-X-6.75	ADAPTOR, MOTOR/PUMP
12	1	PARKER	PVP1630R2	PUMP, PISTON (1 CU. IN./REV.)
13	1	TRIAD	12495-R00-S01	SET, 1201B TAG
14	1	PARKER	RDI02S30	VALVE, CARTRIDGE RELIEF
15	1	PARKER	B10-2-8T	BODY, CARTRIDGE VALVE
16				
17	1	PARKER	15P2050BE2K5121	FILTER, PRESSURE
18	1	PARKER	C820S	VALVE, CHECK
19	2	LHA	CV03S-5	VALVE, CHECK
20	1	PARKER	BA002B3T01A1	ACCUMULATOR, 1 QUART BLADDER
21	1	BOSCH	AD-P1-51F-10	VALVE, ACCUMULATOR DISCHARGE
22	1	SUN	NSAB-KXV-HH	SNUBBER, GAUGE
23	1	NDSHOK	25.3 CFF	FLANGE, CHROME GAUGE
24	1	NDSHOK	25-310-SST-5000-PSI/BAR	GAUGE, PRESSURE W/ORIFICE
25	1	PARKER	H3-62-T8	COUPLER, QUICK DISCONNECT
26	1	PARKER	H3-65	PLUG, COUPLER DUST
27	1	PARKER	1466230000	BRACKET, ACCUMULATOR
28	1	PARKER	H3-63-T8	NIPPLE
29	1	PARKER	H3-66	CAP, NIPPLE DUST
30	1	THERMAL TRANSFER	MR-25-S-30	COOLER, AIR/DIL HEAT EXCHANGER
31	1	TFP	D-10394-R00-S01	HOSE, DRAIN
32	1	TFP	D-5590-A-01 THRU 17	CABINET, POWER UNIT
33	1	McMASTER CARR	13835A85	LATCH, NON-LOCKING
34	2	HOFFMAN	A-L31	LATCH, SLOTTED INSERT
35	2	McMASTER CARR	240BT142	CASTER, SWIVEL
36	2	McMASTER CARR	240BT139	CASTER, RIGID
37	2	McMASTER CARR	2422T99	BRAKE, CASTER
38	1	TRIAD		PACKAGE, ELECTRICAL
39	1	GRAINGER	4C230	BLADE, ALUMINUM FAN
40	1	REGAL BELDIT	3994	MOTOR, ELECTRIC, 1/3 HP @ 1625 RPM
41	1	GRAINGER	4C434	GUARD, AIR CIRCULATION
42	8	TECH PRDDUCTS	51123	MOUNT, ISOLATION
43	1	McMASTER-CARR	93625K22	STRIP, RUBBER, 1/8" THK. X 5/8" WIDE
44				
45				
46	4	McMASTER CARR	3896T2	SLEEVE, ALUM. OVAL FOR 3/32" DIA. WIRE ROPE
47	2 FT	McMASTER CARR	8923T321	ROPE, 7X7 STRAND CORE GALV. STL.
48	1	GRAINGER	2GE80	CAPACITOR, 370 V RUN
49	1	GRAINGER	3MS33	KIT, CAPACITOR MOUNTING
50	1	MAGNALDY	M30012012	HUB, MOTOR COUPLING (1 5/8 X3/8)
51	1	MAGNALDY	M30002406	HUB, PUMP COUPLING (3/4 X 3/16)
52	1	ANCHOR	V43-12-12U	FLANGE, 3/4" NPT CODE 61 4-BOLT
53	1	ANCHOR	V46-12-12U	FLANGE, 3/4" STR. THD. CODE 61 4-BOLT
54	1	TRIAD	11208-R00-S01	PLATE, MOTOR MOUNTING
55	1	PARKER	932617Q	ELEMENT, FILTER (SHIP LOOSE)
56	1	HIRSCHMANN	931 298-004	CONNECTOR, 2 PIN + GRD. NPT TO DIN
57	1	TURCK	VAS22-A653-5M	CONNECTOR, 0-250VAC/VDC 2 PIN+D GRD.
58	1	TURCK	VAS3-A580-2M	CONNECTOR, 0-250VAC/VDC 3 PIN+H12 GRD.
59	1	TRIAD	10265-R00-S01	COMPENSATOR, MANUAL ADJ. PKG.
59A	1	McMASTER-CARR	5543A76	SOCKET, 7/16" 6 PT. DEEP, 1/4" DRIVE
59B	1	McMASTER-CARR	5521A29	JOINT, UNIVERSAL 1/4" DRIVE
59C	1	McMASTER-CARR	5543A54	SOCKET, 3/8" 12 PT. UNIVERSAL
59D	1	McMASTER-CARR	98930A200	BAR STOCK, 1/4" SQUARE KEY
60	1	McMASTER-CARR	B694K12	STRIP, ADHESIVE BACKED FOAM, 1/4"X1/2"

ITEM ID #ESD-120-00134-06-09

DWG# D-12504-R00-S01

NO.	DATE	BY	ZONE	CHANGE DESCRIPTION	NO.	DATE	BY	ZONE	CHANGE DESCRIPTION

THIS DRAWING IS TO BE INTERPRETED USING THE LATEST REVISION OF ANSI/ASME Y14.300 DRAWING STANDARDS.

TOLERANCES UNLESS OTHERWISE SPECIFIED:
 DECIMAL 0.XX ± 0.01
 0.XXX ± 0.005
 0.XXXX ± 0.0005
 FRACTIONS ± 1/32
 ANGULAR ± 1°
 BREAK SHARP CORNERS

AutoCAD LT 2000

DATE: 07-16-09
 REF. NO. 1002741
 APPR. BY: JAS
 SERIAL NO. 10018 HYDRAULIC POWER SUPPLY-PUMP/RESERVOIR
 CUSTOMER: Xcite

SCALE: 1/4
 SHEET 1 OF 1
 DRAWING NO. B-30251

CONFIDENTIAL DOCUMENT, PROPRIETARY INFORMATION NOT TO BE DISCLOSED TO OTHERS WITHOUT THE EXPRESS WRITTEN CONSENT OF TRIAD FLUID POWER INC. THIS DOCUMENT AND OTHER INFORMATION FROM TRIAD FLUID POWER INC. PROVIDE PRODUCT AND/OR SYSTEM OPTIONS FOR FUTURE INVESTIGATION BY USERS HAVING TECHNICAL EXPERTISE. BEFORE YOU SELECT OR USE ANY PRODUCT OR SYSTEM, IT IS IMPORTANT THAT YOU ANALYZE ALL ASPECTS OF YOUR APPLICATION AND REVIEW THE INFORMATION CONCERNING THE PRODUCT OR SYSTEM IN THE CURRENT PRODUCT CATALOG. DO TO THE VARIETY OF OPERATING CONDITIONS AND APPLICATIONS FOR THESE PRODUCTS OR SYSTEMS, THE USER, THROUGH ITS OWN ANALYSIS AND TESTING IS SOLELY RESPONSIBLE FOR MAKING THE FINAL SELECTION OF THE PRODUCTS AND SYSTEMS AND ASSURING THAT ALL PERFORMANCE, SAFETY AND WARNING REQUIREMENTS OF THE APPLICATION ARE MET.

PAINT SPECIFICATION:
(ORDER ALL 3 PARTS)

COMPONENT A : PPG AUE 360-33019 LDW
GLOSS POLYURETHANE ENAMEL
COMPONENT B : PPG AUE-3501 CATALYST
MIX RATIO A TO B = 4 : 1
REDUCER - GRD-4540

SYSTEM REQUIREMENTS

RESERVOIR CAPACITY: 20 GALLONS
FLUID TYPE: DT225
SYSTEM OPERATING TEMPERATURE: 130°F
PUMP FLOW RATE: 5 GPM
SYSTEM OPERATING PRESSURE: 3000 PSI
PUMP COMPENSATING PRESSURE: 3000 PSI
RELIEF VALVE PRESSURE: 3500 PSI
PRESSURE SWITCH SETTING: 10 PSI
ELECTRIC MOTOR: 10 HP @ 1470 RPM
PAINT SPECIFICATION: SEE ABOVE

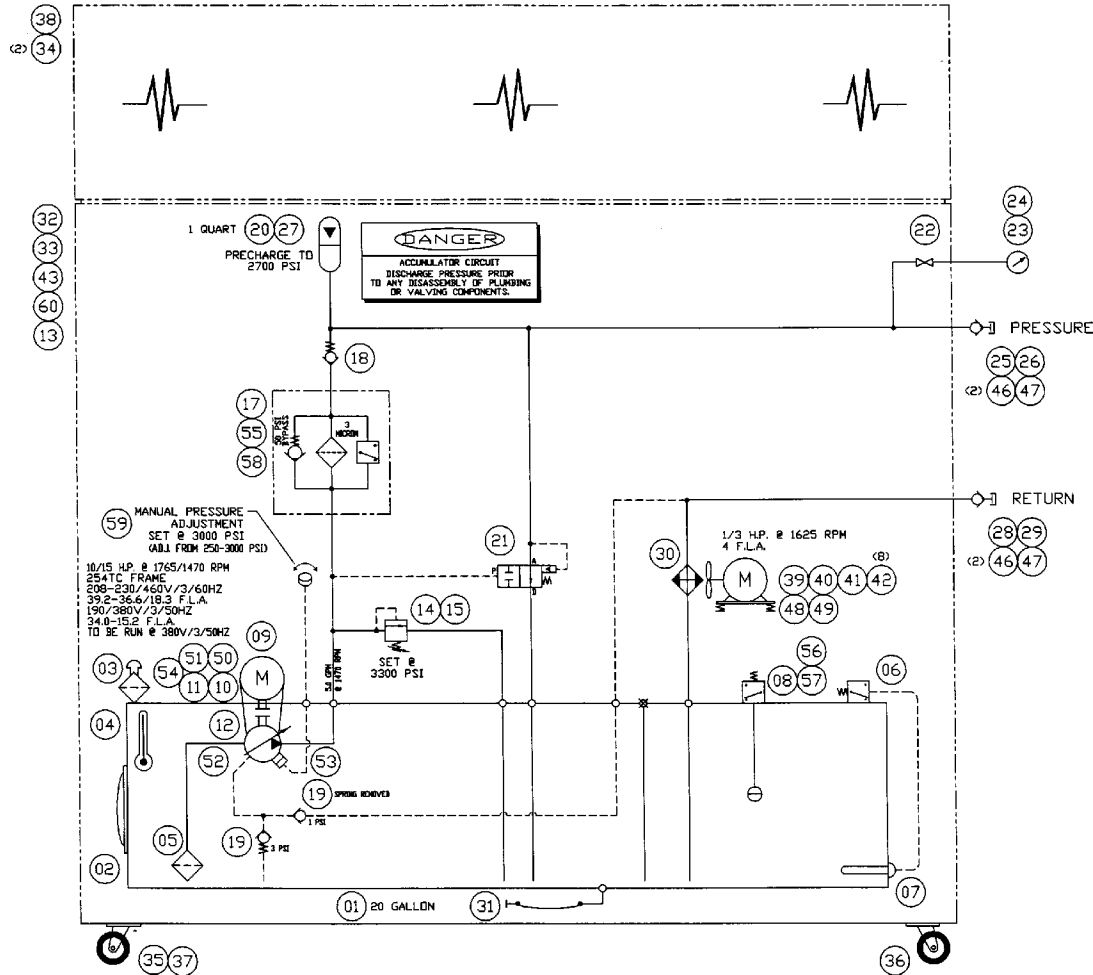

ITEM I.D. # ESD-120-00134-06-09

DWG# D-12491-R00-S01

ITEM	QTY.	MFG.	MODEL NUMBER	DESCRIPTION
01	1	TFP	D-5594-A-01	RESERVOIR, 20 GALLON
02	1	HYDRO-CRAFT	HC-EC-12	COVER, RESERVOIR END
03	1	HYDRO-CRAFT	HC-120	BREATHER, FILLER
04	1	LUBE DEVICES	G1615-05-A-1	GAUGE, SIGHT LEVEL/TEMPERATURE
05	1	HYDRO-CRAFT	HA-FS-5	STRAINER, SUCTION
06	1	ALLEN BRADLEY	837-AA4	SWITCH, TEMPERATURE
07	1	ALLEN BRADLEY	837-N6	BULB WELL
08	1	GEMS	01701	SWITCH, LEVEL
09	1	LEESON	G150102.60	MOTOR, ELECTRIC 15/10 HP#1765/1470 RPM
10	1	MAGNALOY	M370H6	254 FRAME, TEFC W/BASE
11	1	BSF	1102-320-X-6.75	ADAPTOR, MOTOR/PUMP
12	1	PARKER	PVP16302R2	PUMP, PISTON (1 CU. IN./REV.)
13	1	TRIAD	12495-R00-S01	SET, 1201B TAG
14	1	PARKER	RD102S30	VALVE, CARTRIDGE RELIEF
15	1	PARKER	B10-2-8T	BODY, CARTRIDGE VALVE
16				
17	1	PARKER	15P2050BE2KS121	FILTER, PRESSURE
18	1	PARKER	C820S	VALVE, CHECK
19	2	LHA	CV03S-5	VALVE, CHECK
20	1	PARKER	B4002B3TD1A1	ACCUMULATOR, 1 QUART BLADDER
21	1	BOSCH	AD-P1-S1F-10	VALVE, ACCUMULATOR DISCHARGE
22	1	SUN	NSAB-KXV-HH	SNUBBER, GAUGE
23	1	NOSHOK	25.3 CFF	FLANGE, CHROME GAUGE
24	1	NOSHOK	25-310-SST-5000-PSI/BAR	GAUGE, PRESSURE W/DRIFICE
25	1	PARKER	H3-62-T8	COUPLER, QUICK DISCONNECT
26	1	PARKER	H3-65	PLUG, COUPLER DUST
27	1	PARKER	1466230000	BRACKET, ACCUMULATOR
28	1	PARKER	H3-63-T8	NIPPLE
29	1	PARKER	H3-66	CAP, NIPPLE DUST
30	1	THERMAL TRANSFER	MR-25-S-30	COOLER, AIR/OIL HEAT EXCHANGER
31	1	TFP	D-10394-R00-S01	HOSE, DRAIN
32	1	TFP	D-5590-A-01 THRU 17	CABINET, POWER UNIT
33	1	McMASTER CARR	13835A85	LATCH, NON-LOCKING
34	2	HOFFMAN	A-L31	LATCH, SLOTTED INSERT
35	2	McMASTER CARR	2408T142	CASTER, SWIVEL
36	2	McMASTER CARR	2408T139	CASTER, RIGID
37	2	McMASTER CARR	2422T99	BRAKE, CASTER
38	1	TRIAD		PACKAGE, ELECTRICAL
39	1	GRAINGER	4C230	BLADE, ALUMINUM FAN
40	1	REGAL BELDIT	3994	MOTOR, ELECTRIC, 1/3 HP @ 1625 RPM
41	1	GRAINGER	4C434	GUARD, AIR CIRCULATION
42	8	TECH PRODUCTS	51123	MOUNT, ISOLATION
43	1	McMASTER-CARR	93625K22	STRIP, RUBBER, 1/8" THK. X 5/8" WIDE
44				
45				
46	4	McMASTER CARR	3896T2	SLEEVE, ALUM. OVAL FOR 3/32" DIA.
47	2 FT	McMASTER CARR	8923T321	VIRE ROPE
48	1	GRAINGER	2GE80	ROPE, 7X7 STRAND CORE GALV. STL.
49	1	GRAINGER	3M533	CAPACITOR, 370 V RDN
50	1	GRAINGER	3M533	KIT, CAPACITOR MOUNTING
51	1	MAGNALOY	M30012012	HUB, MOTOR COUPLING (1 5/8 X3/8)
52	1	MAGNALOY	M30002406	HUB, PUMP COUPLING (3/4 X 3/16)
53	1	ANCHOR	V43-12-12U	FLANGE, 3/4" NPT CODE 61 4-BOLT
54	1	ANCHOR	V46-12-12U	FLANGE, 3/4" STR. THD. CODE 61 4-BOLT
55	1	TRIAD	11208-R00-S01	PLATE, MOTOR MOUNTING
56	1	PARKER	932617Q	ELEMENT, FILTER (SHIP LODGE)
57	1	HIRSCHMANN	931 298-004	CONNECTOR, 2 PIN + GRD., NPT TO DIN
58	1	TURCK	VAS22-A653-5M	CONNECTOR, 0-250VAC/VDC 2 PIN+D GRD.
59	1	TURCK	VAS3-A580-2M	CONNECTOR, 0-250VAC/VDC 3 PIN+H12 GRD.
59A	1	TRIAD	10265-R00-S01	COMPENSATOR, MANUAL ADJ. PKG.
59B	1	McMASTER-CARR	5543A76	SOCKET, 7/16" 6 PT. DEEP, 1/4" DRIVE
59C	1	McMASTER-CARR	5521A29	JOINT, UNIVERSAL 1/4" DRIVE
59D	1	McMASTER-CARR	5543A54	SOCKET, 3/8" 12 PT. UNIVERSAL
59E	1	McMASTER-CARR	98830A200	BAR STOCK, 1/4" SQUARE KEY
60	1	McMASTER-CARR	8694K12	STRIP, ADHESIVE BACKED FOAM, 1/4"X1/2"

NO.	DATE	BY	ZONE	CHANGE DESCRIPTION	NO.	DATE	BY	ZONE	CHANGE DESCRIPTION

CONFIDENTIAL DOCUMENT. PROPRIETARY INFORMATION NOT TO BE DISCLOSED TO OTHERS WITHOUT THE EXPRESS WRITTEN CONSENT OF TRIAD FLUID POWER INC. THIS DOCUMENT AND OTHER INFORMATION FROM TRIAD FLUID POWER INC. PROVIDE PRODUCT AND/OR SYSTEM OPTIONS FOR FUTURE INVESTIGATION BY USERS HAVING TECHNICAL EXPERTISE. BEFORE YOU SELECT OR USE ANY PRODUCT OR SYSTEM, IT IS IMPORTANT THAT YOU ANALYZE ALL ASPECTS OF YOUR APPLICATION AND REVIEW THE INFORMATION CONCERNING THE PRODUCT OR SYSTEM IN THE CURRENT PRODUCT CATALOG. DO TO THE VARIETY OF OPERATING CONDITIONS AND APPLICATIONS FOR THESE PRODUCTS OR SYSTEMS, THE USER, THROUGH ITS OWN ANALYSIS AND TESTING IS SOLELY RESPONSIBLE FOR MAKING THE FINAL SELECTION OF THE PRODUCTS AND SYSTEMS AND ASSURING THAT ALL PERFORMANCE, SAFETY AND WARNING REQUIREMENTS OF THE APPLICATION ARE MET.

THIS DRAWING IS TO BE INTERPRETED USING THE LATEST REVISION OF MESSAGE, THE DRAWING STANDARDS.

TOLERANCES (UNLESS OTHERWISE SPECIFIED):
DECIMAL: 0.XX ± 0.1
0.XXX ± 0.005
0.XXXX ± 0.0005
FRACTIONS: ± 1/32
ANGULAR: ± 1°
BREAK SHARP CORNERS
AutoCAD LT 2000

JOB NO: 1002741
DRAWN BY: JAS
APP'D BY:
REF. NO.: J4389A
DATE: 06-15-09
DRAWING NO.: ESD993065-1
REF. SNG: D-10390-R00-S01
SCALE: NONE

XCITE SYSTEMS CORPORATION
1218 (2013/50) HYDRAULIC POWER SUPPLY HYDRAULIC SCHEMATIC
CUSTOMER: XCITE SYSTEMS
SHEET 1 OF 1
DRAWING NO.: B-30252

380/3/50
460/3/60

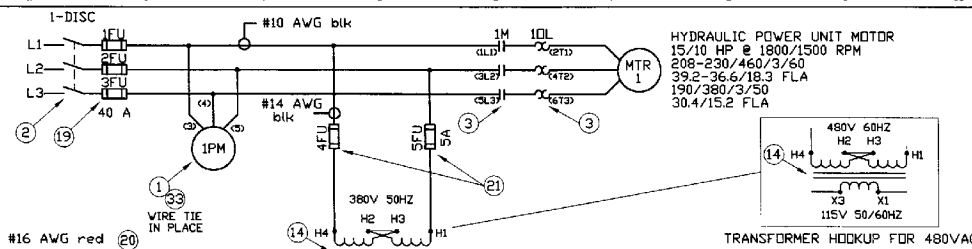

ITEM	QTY.	MFG.	MODEL NUMBER	DESCRIPTION
01	1	DIVERSIFIED ELECT.	PRA-100-AFA	PHASE MONITOR
02	1	ALLEN BRADLEY	194R-NJ060P34ER1	DISCONNECT, 60A FUSIBLE
03	1	C3 CONTROLS	620-S32D10-2U23	CONTACTOR, WITH OVERLOAD
04	1			
05	1	C3 CONTROLS	GPRS-P2C10D-1	RELAY, 10A
06	1	C3 CONTROLS	GPRA-SPO8U1	RELAY SOCKET
07	3	C3 CONTROLS	FVPTT120-IPBCRD	LIGHT, PILOT, RED
08	1	C3 CONTROLS	FVPTT120-IPBCAD	LIGHT, PILOT, AMBER
09	1	C3 CONTROLS	FVPTT120-IPBCGD	LIGHT, PILOT, GREEN
10	2	C3 CONTROLS	GPRM-B4C05D	RELAY, 5A CONTACTS
11	2	C3 CONTROLS	GPRA-SB14U1	SOCKETS, RELAY
12	1	C3 CONTROLS	FVPPM120-IMCRD-NO-NC	PUSH-BUTTON, E STOP, ILL.
13	1	ALLEN-BRADLEY	800T-X648J	LEGEND PLATE (E STOP)
14	1	HEVI-DUTY	E750TF	TRANSFORMER, 750 VA
15				
16				
17	2	C3 CONTROLS	GPRA-RC3	RETAINER CLIP, RELAY
18	2	C3 CONTROLS	GPRA-RC4	RETAINER CLIP, RELAY
19	3	BUSSMANN	LPJ-40SP	FUSE, 40A
20	1	BUSSMANN	FNM-10	FUSE, 10A
21	2	BUSSMANN	FNQ-R-5	FUSE, 5A
22	1	HUBBELL	HBL26422	CONNECTOR, MALE
23	1	HUBBELL	HBL26418	CONNECTOR, FEMALE
24	20 FT	--	6/4 SD	CABLE, 6 AWG, 4 COND.
25	1	MCMASTER CARR	1672-T84	HOOR METER, 50/60HZ
26	1	AMPHENDL	97-3102A18-12S	CONNECTOR, FEMALE, 6 PIN
27	23	PHENIX CONTACT	3004362	TERMINAL BLOCKS
28	2	PHENIX CONTACT	0441504	TERMINAL BLOCK, GROUND
29	1	PHENIX CONTACT	0801733	DIN RAIL
30	2	PHENIX CONTACT	0800886	TERMINAL BLOCK END ANCHOR
31	1	PHENIX CONTACT	3003020	TERMINAL BLOCK END COVER
32	10 FT	ALPHA	1898/12C	CABLE, 12 CONDUCTOR
33	1	C3 CONTROLS	GPRA-SPO8U1	SOCKET, 8-PIN
34	1	TFP	D-10222-R00-S01	CUSTOM LEGEND PLATES

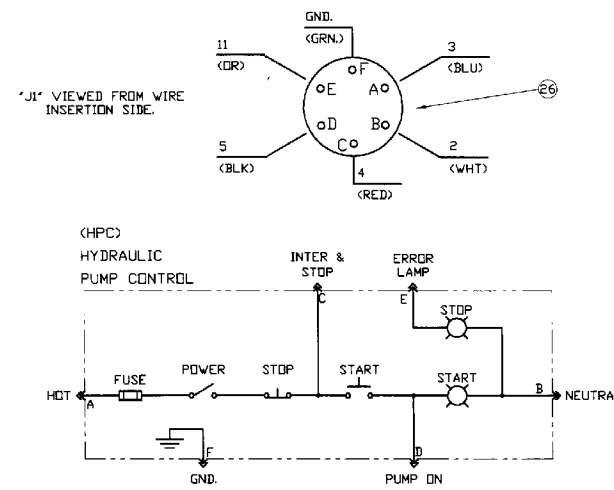

NO.	DATE	BY	ZONE	CHANGE DESCRIPTION	NO.	DATE	BY	ZONE	CHANGE DESCRIPTION

CONFIDENTIAL DOCUMENT. PROPRIETARY INFORMATION NOT TO BE DISCLOSED TO OTHERS WITHOUT THE EXPRESS WRITTEN CONSENT OF TRIAD FLUID POWER INC. THIS DOCUMENT AND OTHER INFORMATION FROM TRIAD FLUID POWER INC. PROVIDE PRODUCT AND/OR SYSTEM OPTIONS FOR FUTURE INVESTIGATION BY USERS HAVING TECHNICAL EXPERTISE. BEFORE YOU SELECT OR USE ANY PRODUCT OR SYSTEM, IT IS IMPORTANT THAT YOU ANALYZE ALL ASPECTS OF YOUR APPLICATION AND REVIEW THE INFORMATION CONCERNING THE PRODUCT OR SYSTEM IN THE CURRENT PRODUCT CATALOGS, AS TO THE VARIETY OF OPERATING CONDITIONS AND APPLICATIONS FOR THESE PRODUCTS OR SYSTEMS. THE USER, THROUGH ITS OWN ANALYSIS AND TESTING IS SOLELY RESPONSIBLE FOR MAKING THE FINAL SELECTION OF THE PRODUCTS AND SYSTEMS AND ASSURING THAT ALL PERFORMANCE, SAFETY AND WARNING REQUIREMENTS OF THE APPLICATION ARE MET.

THIS DRAWING IS TO BE INTERPRETED USING THE LATEST REVISION OF ANSI/ASME Y14 DRAFTING STANDARDS.

TOLERANCES UNLESS OTHERWISE SPECIFIED:
DECIMAL .XXX ± .01
0.000X ± .005
FRACTIONS ± 1/32
ANGULAR ± 1°
BREAK SHARP CORNERS

JOB NO. 1002741
DRAWN BY JAS
APP'D BY 1000544
DATE 07-20-09
SCALE NONE

DWG# D-12493-R00-S01

XCITE SYSTEMS CORPORATION
CUSTOMER XCITE SYSTEMS
SHEET 1 OF 2 DRAWING NO. B-30253

ELECTRICAL ENCLOSURE DOOR

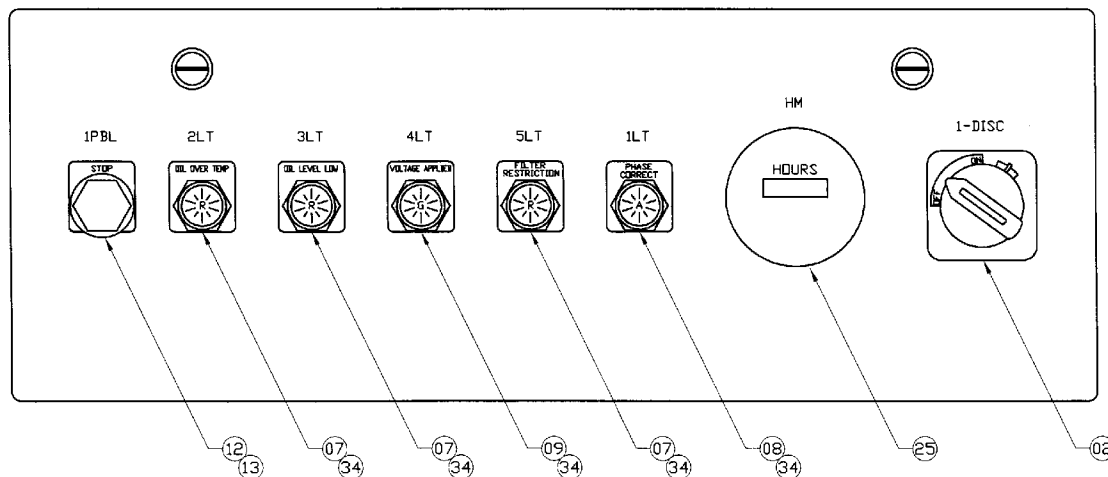

ELECTRICAL ENCLOSURE PANEL

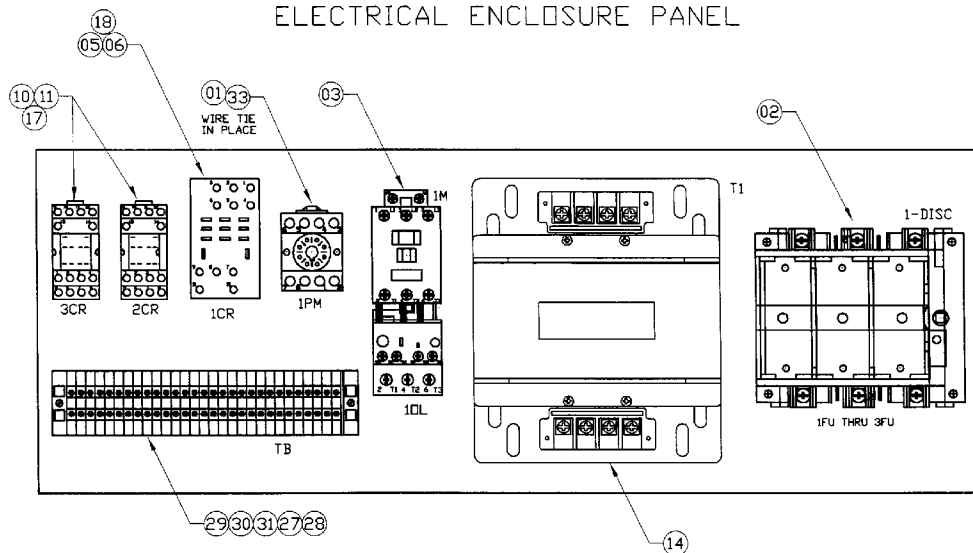

Dwg# D-12493-R00-S02

THIS DRAWING IS TO BE INTERPRETED USING THE LATEST REVISION OF ANSI/ASME Y14 DRAFTING STANDARDS.		TOLERANCES UNLESS OTHERWISE SPECIFIED: DECIMAL 0.XX ± 0.01 0.XXXX ± 0.005 FRACTIONS ± 1/32 ANGULAR ± 1° BREAK SHARP CORNERS		JOB NO. 1002741 REF. NO. 1000544 SERIE NO. ESD093065-1 REF. DWG. 11764-R00-S02 AutocAD LT 2006	DRAWN BY JAS APPR BY DATE 07-20-09 SCALE NONE		1203 (380/350) HYDRAULIC POWER SUPPLY-ELECTRICAL BOX LAYOUT DRAWING NAME XCITE SYSTEMS CUSTOMER	SHEET 1 OF 1 DRAWING NO. B-30254																	
<table border="1"> <thead> <tr> <th>NO.</th> <th>DATE</th> <th>BY</th> <th>ZONE</th> <th>CHANGE DESCRIPTION</th> </tr> </thead> <tbody> <tr> <td> </td> <td> </td> <td> </td> <td> </td> <td> </td> </tr> </tbody> </table>		NO.	DATE	BY	ZONE		CHANGE DESCRIPTION						<table border="1"> <thead> <tr> <th>NO.</th> <th>DATE</th> <th>BY</th> <th>ZONE</th> <th>CHANGE DESCRIPTION</th> </tr> </thead> <tbody> <tr> <td> </td> <td> </td> <td> </td> <td> </td> <td> </td> </tr> </tbody> </table>		NO.	DATE	BY	ZONE	CHANGE DESCRIPTION						<p>CONFIDENTIAL DOCUMENT, PROPRIETARY INFORMATION NOT TO BE DISCLOSED TO OTHERS WITHOUT THE EXPRESS WRITTEN CONSENT OF TRIAD FLUID POWER INC. THIS DOCUMENT AND OTHER INFORMATION FROM TRIAD FLUID POWER INC. PROVIDE PRODUCT AND/OR SYSTEM OPTIONS FOR FUTURE INVESTIGATION BY USERS HAVING TECHNICAL EXPERTISE. BEFORE YOU SELECT OR USE ANY PRODUCT OR SYSTEM, IT IS IMPORTANT THAT YOU ANALYZE ALL ASPECTS OF YOUR APPLICATION AND REVIEW THE INFORMATION CONCERNING THE PRODUCT OR SYSTEM IN THE CURRENT PRODUCT CATALOG. DO TO THE VARIETY OF OPERATING CONDITIONS AND APPLICATIONS FOR THESE PRODUCTS OR SYSTEMS, THE USER, THROUGH ITS OWN ANALYSIS AND TESTING IS SOLELY RESPONSIBLE FOR MAKING THE FINAL SELECTION OF THE PRODUCTS AND SYSTEMS AND ASSURING THAT ALL PERFORMANCE, SAFETY AND WARNING REQUIREMENTS OF THE APPLICATION ARE MET.</p>
NO.	DATE	BY	ZONE	CHANGE DESCRIPTION																					
NO.	DATE	BY	ZONE	CHANGE DESCRIPTION																					

1100, 1200 and 1300 Master Controller



1. Introduction

The Xcite Master Controller is a compact electronics control package designed to provide all the controls and displays necessary to operate an Xcite exciter system. The latest concepts in electronic design, including plug-in printed circuit boards, flexible systems interface and easy-to-use operator controls, are incorporated in the unit.

The Master Controller represents the heart of the closed loop hydraulic exciter system. It enables two variables to be independently controlled simultaneously via the Static Level and Dynamic Level controls. It incorporates automatic gain control in the dynamic loop which allows a constant amplitude of the dynamic variable to be maintained even as the reference frequency of excitation is changed.

2. Theory of Operation

The major design concept used in the Xcite Master Controller is one of providing accurate feedback control of an exciter head's capability, such as force, displacement, velocity, acceleration, etc.

The Master Controller senses the feedback signals from the appropriate transducers and provides an output drive signal to the exciter head servovalve which will cause the exciter to maintain the desired levels of the static and dynamic variable as determined by the dynamic and static level controls.

2.1. Configurations

The master controller can be operated in either a single- or dual-loop configuration.

2.1.1. Single Loop

Single-loop operation is selected by placing the Frequency Range switch to the *LOW* position. This mode is generally used to control a single variable, usually force or displacement. In this *LOW FREQUENCY* mode of operation, a dynamic signal is generated by summing the reference frequency present at the *PROGRAM INPUT* with the Static Level set point signal.

2.1.2. Dual Loop

Dual-loop operation is selected by placing the *FREQUENCY RANGE* switch to the *HIGH* position. This mode applies the dynamic feedback signal to the dynamic control loop which incorporates an automatic gain control circuit. This allows a desired dynamic amplitude variable to be set and maintained over a broad frequency range and structure stiffnesses.

3. Description

The Xcite Master Controller (Model 1104, 1204 and 1304) has a variety of inputs and switch selectors which allows the various operational modes of the Exciter Head. Listed below is a description of each connector, switch and indicator located on the Master Controller.

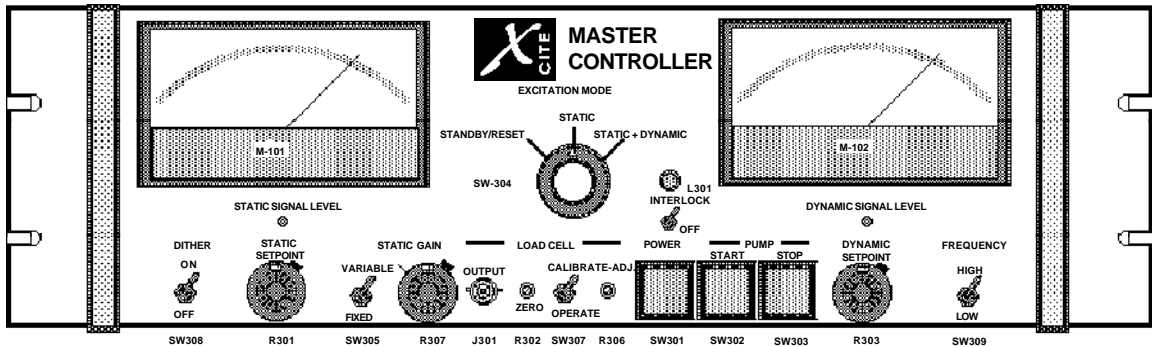

Front Panel

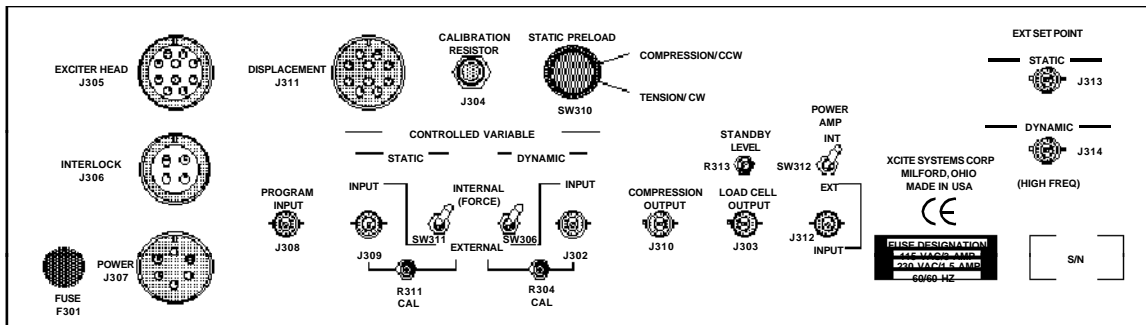

MASTER CONTROLLER REAR PANEL (OUTSIDE VIEW)

Outside Rear Panel

3.1. Front Panel (Left and Right Top Section)

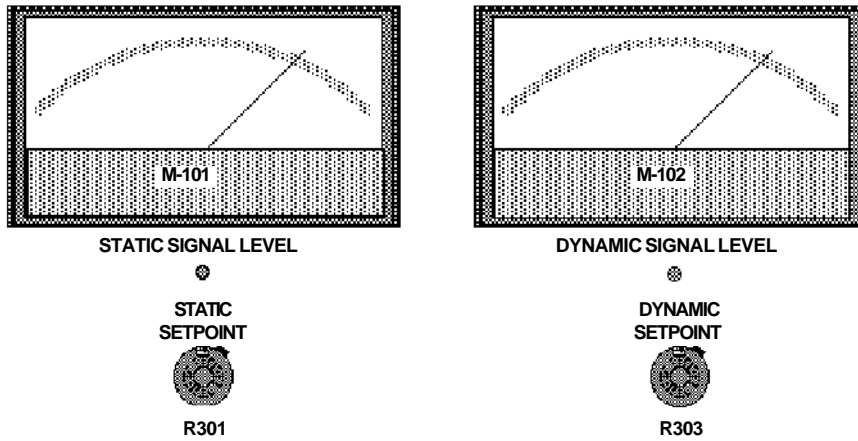

3.1.1. Static Signal Level Meter (M-101)

The Static Signal Level is displayed on this meter in Static Force Pounds or Static Displacement.

3.1.2. Static Set Point (R301)

Potentiometer used to set value of desired static variable. The Static Set Point potentiometer is calibrated in percent full scale.

3.1.3. Dynamic Signal Level Meter (M-102)

The Dynamic Signal Level is displayed on this meter in Peak Dynamic Force Pounds.

3.1.4. Dynamic Set Point (R303)

Potentiometer used to set value of desired dynamic variable. The Dynamic Set Point potentiometer is calibrated in Peak Dynamic Force Pounds.

3.1.5. Excitation Mode (SW304)

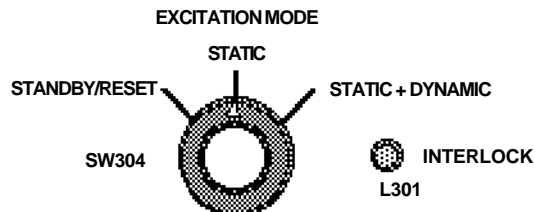

Used to select operating mode of exciter head. Turn the switch so that the arrow points to the mode of interest.

Standby/ Reset

Exciter head is at (or returns to) standby position, as preset by set-screw potentiometer on rear of Master Controller. The interlock circuits are also reset in this mode.

Static

Only the static control loop is activated.

Static + Dynamic

The static and dynamic control loops are activated.

3.1.6. Interlock Selector Switch (Optional) and Light 301

The Interlock Selector Switch (provided only on Master Controllers operating torsional Exciter Heads) located directly below the red Interlock Light is used to disable the Interlock system when in the *STATIC MODE* position. Normal Interlock occurs when the switch is in the *UP* position. Disabled Interlock occurs when the switch is in the *DOWN* position.

The Interlock Light indicates when interlock circuits are activated, causing exciter head to return to standby position. Excitation mode control switch must be moved to Reset position to continue operation.

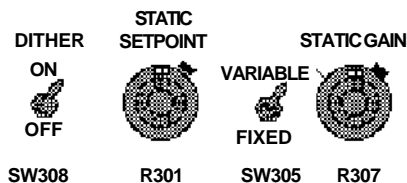
3.1.7. Dither - ON/ OFF (SW308)

Front Panel (Left) - Bottom Section

Toggle switch which, when in *ON* position, provides 400 Hz signal to exciter servovalve. It is used primarily to overcome exciter stiction at low frequencies of operation. (Below 5 Hz)

3.1.8. Static Set Point (R301)

Indicates desired static level. Calibrated in percent full scale. **See 3.1.2.**

3.1.9. Static Gain**Static Gain - Variable/ Fixed (SW305)**

Toggle switch. In *VARIABLE* position actuates loop static gain potentiometer (R307).

Static Gain (R307)

Potentiometer used to set static control loop gain based on the stiffness of the structure under test. Used to eliminate control loop instabilities when using exciter in Static Displacement Mode on a weak structure.

3.1.10. Load Cell

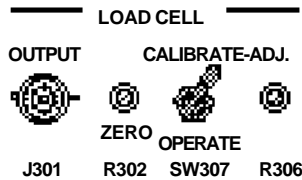

Front Panel (Middle) - Bottom Section

Output (J301)

BNC connector providing load cell output signal for monitoring of the force signal (varies from -10V to +10V depending on the actual value of the force). Duplicated on back of controller.

Zero (R302)

Set screw potentiometer used to zero the load cell output when there is no load applied.

3.1.11. Calibrate/ Operate (SW307)

Adj. (R306)

Set screw potentiometer used to adjust the master controller for the calibration value of the load cell when (SW307) is in the calibrate mode. (See load cell calibration plug for calibration value).

Operate

Select the operate mode of load cell once calibration is complete.

3.1.12. Power (SW301)

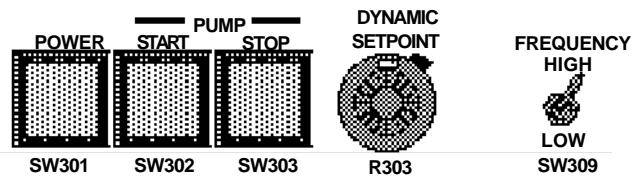

Front Panel (Right) - Bottom Section

Push switch for supplying power to master controller.

3.1.13. Pump**Start (SW302)**

Push switch with internal red indicator light to energize power supply.

Stop (SW303)

Push switch to de-energize hydraulic power supply.

3.1.14. Dynamic Set Point (R303)

Indicates desired peak dynamic level. Calibrated in engineering units. **See 3.1.4.**

3.1.15. Frequency Range - HIGH/ LOW (SW309)

HIGH - Compressor control of dynamic signal at 5 Hz and above.
LOW - Single loop control of force or displacement.

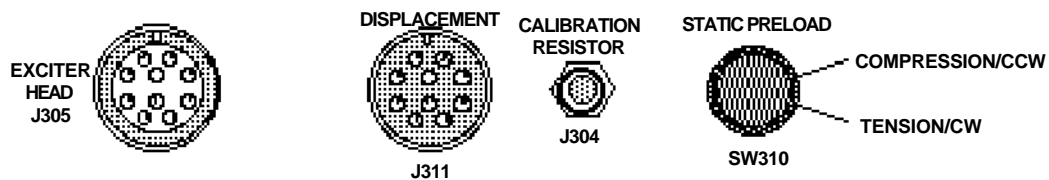
3.2. Rear Panel

Rear Panel - Top Section

3.2.1. Exciter Head (J305)

Input connection for servovalve and load cell cable from exciter head.

3.2.2. Displacement (J311)

Input connection for displacement transducer cable from exciter head.

3.2.3. Calibration Resistor (J304)

Jack input for calibration plug provided with Load Cell Transducer.

3.2.4. Static Preload (SW310)

Dual-position switch establishes sign convention of static preload. When exciter head is operated by “pushing” on the test article, this switch should be in the *COMPRESSION* position. If exciter head is operated by “pulling” on the test structure, this switch should be in the *TENSION* position.

3.2.5. Interlock (J306)

Input connect for interlock function. If external control of this function is not desired, an Xcite supplied mating connector with pins C and D shorted must be used. If user supplied external control is desired, then appropriate contact closure between pins C and D must be supplied. Pins A and B are supplied for interlock of additional external equipment, as required.

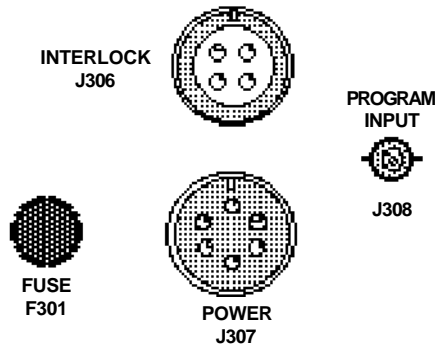

Rear Panel (Left) - Bottom Section

3.2.6. Power (J307)

Input connection for cable from hydraulic power supply. When a non-Xcite hydraulic power supply is used, this is the input connection for the direct 110V AC power cord.

3.2.7. Fuse (F301)

Use 3 amp fuse for 115 VAC. Use 1.5 amp fuse for 230 VAC.

3.2.8. Program Input (J308)

Input connection for signal from reference oscillator.



A 1 volt RMS signal must be provided to ensure system control calibration.

3.2.9. Controlled Variable - Static

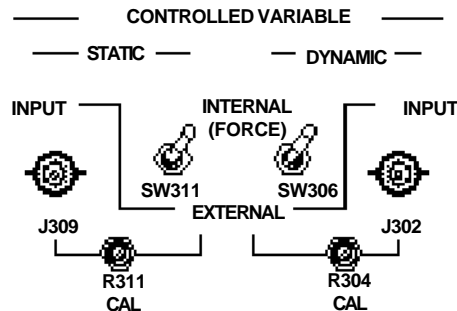

Rear Panel (Middle) - Bottom Section

Input (J309)

Input BNC connection for externally supplied user-specified static feedback variable. Input signal level should be 5 volts minimum full scale. Also used for Displacement Transducer feedback from the Exciter Head.

Internal/ External (SW311)

Toggle switch to select as the static controlled variable either the internally available load cell transducer signal or an externally supplied user-specified static feedback signal.

Cal. (R311)

Set screw potentiometer used to scale externally supplied static feedback variable to 5 volts full scale. Factory set for scaling 10 volts to 5 volts.

3.2.10. Controlled Variable - Dynamic

Input (J302)

BNC connection for externally supplied user-specified dynamic feedback variable. Input signal level should be 5 volts peak (minimum) full scale.

Internal/ External (SW306)

Toggle switch to select as the dynamic controlled variable either the internally available load cell transducer signal or an externally supplied user-specified dynamic feedback signal such as acceleration.

Cal. (R304)

Set screw potentiometer used to scale down externally supplied dynamic feedback variable to 5 volts peak full scale.

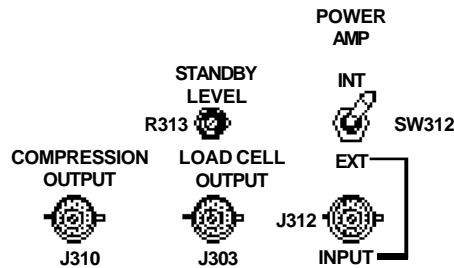

Rear Panel (Left) - Bottom Section

- 3.2.11. Compression Output (J310)**
BNC connection providing an output signal which is proportional to dynamic forward control signal (servovalve drive signal) after multiplication by reference oscillator signal.
- 3.2.12. Standby Level (R313)**
Set screw potentiometer determining static level when Master Controller is in standby or interlock mode.
- 3.2.13. Load Cell Output (J303)**
BNC connector providing load cell output signal for monitoring of the force signal (+/- 10V max). Duplicated on front of controller.
- 3.2.14. Power Amp - INT/ EXT (SW312)**
Toggle switch to select input signal to power amplifier. *INTERNAL* position is used for normal operation and provides dynamic control signal proportional to level requested on the front of the Master Controller at the reference oscillator frequency. *EXTERNAL* position is used for external dynamic control applications such as random or shaped random signals from an FFT Analyzer or random noise generator. In *EXTERNAL* position, the *DYNAMIC SET POINT* (R303) potentiometer on the front panel attenuates the external dynamic control signal and the *DYNAMIC SIGNAL LEVEL METER* (M-102) indicates 1.41 times the true RMS voltage of the dynamic variable feedback level.
- 3.2.15. Power Amp - INPUT (J312)**
BNC connector used to supply external control signal source with *POWER AMP* toggle switch on *EXTERNAL*. Use only J308 *PROGRAM INPUT* with toggle switch on *INTERNAL*.

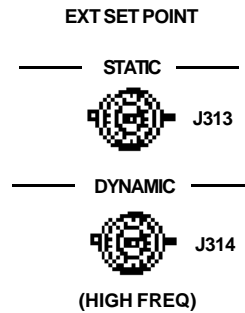

Rear Panel (Right) - Top Section

3.2.16. EXT Set Point - Static (J313)

Allows computer control of the Static Set Point by inputting a voltage from a DAC (Digital to Analog Converter). Typically this function is used when it is desired to have an automatic test sequence from a computer controlled FFT Analyzer.



CAUTION: This input is ALWAYS live and will activate the static control loop whenever a DAC voltage is present.

The EXT Static Set Point has the following characteristics:

- It is **ALWAYS** operable in the Standby, Static and Static + Dynamic modes.
- The input voltage from the DAC should be 0 to +5VDC, +/-5% to achieve full scale control of the Static Controlled Variable.

Note: Always use a positive DC DAC voltage for this function.

- The input voltage from the DAC will add to the Static Set Point. (ie - If the Static Set Point Dial is set to 5.0 (1/2 of full stroke in displacement mode) then the EXT DAC voltage input will add to the Set Point on the Set Point Dial.

3.2.17. EXT Set Point - Dynamic (J314)

Allows computer control of the Dynamic Set Point by inputting a voltage (NOT frequency) from a DAC (Digital to Analog Converter). Typically this function is used when it is desired to have an automatic test sequence from a computer controlled FFT Analyzer.



CAUTION: *This input is live when the Mode Control Switch is in the Static + Dynamic Mode. Dynamic Force output will occur whenever a DAC voltage is present at this input.*

The EXT Dynamic Set Point has the following characteristics:

- It operates in the Static + Dynamic Mode.
- It only operates in the High Frequency Range

Note: Never use in the Low Frequency Range Mode

- The input voltage from the DAC should be 0 to -5VDC, +/-5% to achieve full scale control of the Dynamic Controlled Variable.

Note: Always use a negative DC DAC voltage for this function.

- The input voltage from the DAC will add to the Dynamic Set Point. (ie - If the Dynamic Set Point Dial is set to 5.0, then the EXT DAC voltage input will add to the Set Point value. In this example a DAC voltage of -2.5V will make the Set Point 100%).

4. Operation

4.1. Concept of Operation

The Xcite Master Controller is designed so that the variables to be controlled can be readily selected by the positions of the Controlled Variable switches located on the rear panel of the controller.

When the Controlled Variable switches are in the Internal position, the controlled variable will be force. The force feedback signal is internally routed to the static and dynamic control loops. The composite force signal is separated by a low-pass and high-pass filter, with the DC and AC levels of the composite signal being displayed by the Static and Dynamic meters, respectively.

If a variable(s) other than force is to be controlled, the Controlled Variable switches can be placed in the External position and feedback from the variable to be controlled can be applied to the External Static and/ or External Dynamic inputs. This allows alternate variables such as displacement to be statically and dynamically controlled, or two variables such as static displacement and dynamic force to be controlled.

4.2. System Interconnection

Mount the exciter head to be operated securely in its test configuration and connect the hydraulic pump hoses to the exciter.

- 4.2.1. Exciter head cable (J305 to servovalve and load cell)
- 4.2.2. Displacement kit cable (J311 to exciter displacement kit)
- 4.2.3. Power cord or pump cable (J307 to J501 or 110 VAC)
- 4.2.4. Reference oscillator to Program input J308 (1 V RMS +/- 50 MV)
- 4.2.5. Connect an oscilloscope and/ or D.V.M. to Load Cell outputs J301 or J303.

4.3. Operation - Force Control

To operate the exciter under force control, place the following switches and controls in the positions given.

4.3.1. Set Controls

MODE CONTROL	STANDBY/RESET
DITHER	OFF
LOOP GAIN	FIXED (If test specimen static stiffness is less than 10,000 lbs/inch, place in variable & set variable gain control at 5.00)
FREQUENCY RANGE	HIGH
STATIC SET POINT	0
DYNAMIC SET POINT	0
STATIC CONTROLLED VARIABLE	INTERNAL
DYNAMIC CONTROLLED VARIABLE	INTERNAL
TENSION/ COMPRESSION	COMPRESSION

4.3.2. Depress the Power switch

The controller will energize and a momentary deflection of the meter pointers may occur.

4.3.3. Adjust Load Cell

- Adjust the load cell zero adjust for 0 Volts on a digital volt meter. Refer to the Calibration plug located on the rear of the controller for the load cell calibrate value and the output sensitivity of the controller.
- Place the load cell calibrate switch in the calibrate position. If necessary, adjust the load cell calibrate screw until the voltage measured by the digital volt meter equals the calibration voltage. The calibration voltage equals the calibration value divided by the output sensitivity.

Example:

Cal. Value = 742 lbs

Output Sens. = 250 lbs/v

therefore: $742/250 = 2.968v$ at J301/ J303

- Return the load cell calibrate switch to the operate position.

4.3.4. Depress Pump Start Button

The Hydraulic Power Supply should energize.

- Set the Mode Control switch to the Static position.
- Slowly turn the Static Set Point clockwise until the required static force is obtained, as indicated on the Static Meter. If operating into a "weak" structure, static force instability may occur. If this should happen, adjust the Variable loop gain counterclockwise until static stability is achieved.
- Set the reference oscillator to the desired excitation frequency.
- Set the Mode Control switch to Static + Dynamic position.
- Turn the Dynamic Set Point clockwise until the desired dynamic force is obtained.

Note: Refer to the Exciter Head specifications for maximum peak force versus frequency.

- If swept sine test are to be run, the sweep rate of the oscillator will have to be adjusted so that the dynamic level does not decrease as the frequency is swept upward. If this occurs, lower the sweep rate until the dynamic level is maintained as the oscillator frequency is swept.

4.4. Operation - Displacement Control

If the exciter head is to be operated under displacement control, place the controller switches in the following positions.

4.4.1. Set Controls

MODE CONTROL	STANDBY/RESET
DITHER	OFF
LOOP GAIN	VARIABLE (Variable loop gain control at 5.00)
FREQUENCY RANGE	LOW
STATIC LEVEL	0
DYNAMIC LEVEL	0
STATIC CONTROLLED VARIABLE	EXTERNAL
DYNAMIC CONTROLLED VARIABLE	INTERNAL
TENSION/ COMPRESSION	COMPRESSION

- Energize the controller and the hydraulic power supply.
- Switch the Mode Control to the Static position.
- Turn the Static Set Point potentiometer until the desired static position is reached. The static position can be read on the Static Meter in percent of full stroke. For instance, if the exciter head being used has a 1 inch stroke and the Static meter reads 40%, then the exciter piston is extended 40% of one inch or .4 inch.

The exciter piston position can be dynamically varied by turning the Mode Control switch to the Static + Dynamic position and adjusting the Dynamic Level control for the desired stroke. The Dynamic meter will not indicate the peak displacement in this mode of operation. It will be necessary to monitor the displacement signal at the External Static Variable input jack J309. The input signal at this point will be 0 - 10 VDC. If the exciter has a 1 inch stroke, then full stroke will be equal to 10 VDC. On torsional exciters, 10 VDC represents 100 degrees of rotation.

If compressor control is desired, the Frequency Range should be set to the High position and the displacement input also connected to the Dynamic External Static input J302. At frequencies below approximately 5 Hz full stroke of the exciter may not be obtained in the High Frequency mode. However, the amplitude of the 1 V RMS signal from the reference oscillator may be increased to obtain a slightly larger dynamic stroke.

4.5. Operation - External Variable

Operation using the External Static and Dynamic controlled variable inputs is very similar to the operation using the internal controlled variable. One requirement, however, is that the external variables be scaled to the full scale value of the Static and Dynamic meters. This is accomplished by adjusting the External Cal. potentiometers. A 5 VDC signal is required for full scale deflection of the Static meter and a 5 V peak signal is required for full scale deflection of the Dynamic meter. The Static External Cal. potentiometer is factory adjusted for 10 VDC full scale static signal. The Dynamic Cal. potentiometer is adjusted for a 5 V peak dynamic signal. If signals larger than these are to be used, the Cal. potentiometer should be readjusted so that those signals will cause full scale deflection of the meters.

4.6. Computer Control - External Set Points (Static and Dynamic)

As explained in Section 3.2.16. and Section 3.2.17., it is possible to have a computer controlled FFT Analyzer control the Static and Dynamic Set Points of the Master Controller. Separate DAC output voltages are required for the Static Set Point and Dynamic Set Points. The Static DAC output must be a positive voltage and the Dynamic DAC output must be a negative voltage.

When using an external computer to input the Static and Dynamic Set Points, attention must be paid to the consequences of inputting a DAC voltage when the Hydraulic Power Supply is turned on. The Exciter Head will attempt to operate when these signals are present even with the Mode Control Switch in Standby.

STRUCTURE DAMAGE OR PERSONAL INJURY CAN OCCUR IF THE TEST SEQUENCE IS NOT THOROUGHLY PLANNED.

5. Theory of Operation

The Xcite Master Controller consists of seven major circuits. They are:

- Static control circuitry
- Dynamic control circuitry
- Power amplifier
- Load cell amplifier
- Displacement transducer buffer/ amplifier
- Interlock circuitry
- Pump/ start/ stop

Each section is described in detail as follows.

5.1. Circuit Descriptions

Refer to the Master Controller block diagram and to the appropriate printed circuit board schematics for the following circuit descriptions.

5.1.1. VR101 (Voltage Regulator)

Provides the excitation voltage for the load cell. The regulated voltage is determined by the values of R169 and R170.

$$V_{out} = \frac{1.25V(1 + R170)}{R169}$$

To calibrate the load cell, place a precision shunt resistance (Cal. Plug provided with each load cell) into J304 and place the load cell calibrate/ operate switch SW307 in the calibrate position. This causes an imbalance of the load cell bridge and results in an output of the load cell amplifier A109. The excitation voltage to the load cell is then varied by adjusting R306 until the output of A109 corresponds to the calibration value of the load cell, as given on the calibration plug.

5.1.2. SW310 (Preload Switch)

Allows the outputs of the load cell to be reversed before being applied to A109. This will cause the exciter head to operate in a tension mode, instead of a compression mode.

5.1.3. A109 (Amplifier)

A109 is a precision differential instrumentation amplifier used to amplify the differential voltages from the load cell bridge. R166 and A108 allow the output of A109 to be scaled to a convenient engineering unit for monitoring purposes. The output of A108 is available at BNC jacks on the front and rear of the Master Controller.

The output of A109 is also applied to SW311 and SW306. When these switches are in the *INTERNAL* position, the force signal is applied to the static and dynamic loops as the feedback signal and controlled variable.

5.1.4. **A104 and A105 (Static Control Loop)**

The static control loop consists of A105 and A104. A105 is a dual op-amp. A105B is a low-pass filter which allows the static portion of the feedback signal to be indicated by the static meter. A105A is an inverter/ buffer stage. R137 allows calibration of the dynamic level control when operating in the *LOW FREQUENCY* force control. R135 allows calibration in the *LOW FREQUENCY* displacement control.

The feedback signal from A105A is summed with the static level signal at the summing junction of A104. A104 is a low-pass filter which provides high DC gain which rolls off at 6DB/ octave at a breakpoint determined by R174 and C108. R176, R102 and R113 determine the DC gain of A104. The output of A104 is applied through SW311 and / or K201 and to the appropriate feedback path as determined by the controlled variable.

The output of A104 is also applied to R133 and enables the static loop gain to be adjusted for optimum operation of the exciter head under force control. Further operator adjustment of the static loop gain is provided by R307 when the *GAIN* switch SW305 is in the *VARIABLE* position.

5.1.5. **A401 and A402 (Dynamic Loop)**

The dynamic loop has two main circuits. One circuit, consisting of A401 and A402, demodulates the incoming reference frequency and converts it to a DC reference signal which is applied to the Dynamic Level Control, R303.

The dynamic demodulator circuit consist of a low-pass filter A103, and a true RMS-to-DC converter, U102. The DC portion of the force signal is blocked by C109. The output of U102 is a DC signal. This DC is summed with the dynamic set point signal from the wiper of R303. The resultant error signal is integrated by A012 and C104. This DC error signal is applied to one input of the four-quadrant multiplier, U101. The reference frequency supplied by the reference oscillator is supplied to the other input of U101. The output of U101 is a signal with

a frequency identical to the reference frequency and with an amplitude equal to the product of the two input signals. A101A converts the current output of U101 to a voltage. A101B provides output offset capabilities. C101 and C102 allow the dynamic signal to have two breakpoints at higher frequencies, as required to prevent the servovalve drive signal from clipping.

The output of U101 and A104 are applied to summing amplifier A201. The dither signal is also summed at this point if it is selected by the dither switch. The output of A202 is a composite error signal which is then applied to the power amplifier.

The power amplifier is a voltage-to-current converter circuit. The output current will remain constant for a given input voltage, even though the load impedance (servovalve coils) changes.

5.1.6. A107 (Inverter Buffer)

This circuit allows the displacement transducer to be offset and scaled to convenient engineering units. The scaled displacement signal is fed out through J311/ G into a BNC cable which is then connected to J309. By placing the Static controlled variable switch in the External position, displacement will become the static controlled variable.

5.1.7. A106 and U103 (Peak Detector Circuit)

A106 and U103 form a peak detector circuit which can be adjusted if an absolute value of displacement is exceeded. It is primarily used with inertial mass exciter heads, and only appears in Master Controllers with the MOD2 option.

The interlock circuitry provides a means of insuring that the systems always power up to a preset level, determined by Standby level pot. If power is applied to the Master Controller with the Mode Control switch in either the Static or Static + Dynamic position, the system will interlock. The Mode Control switch must then be placed in the Standby/ Reset position. The Hydraulic Power Supply must also be energized before proceeding to the desired mode of operation.

6. Specifications

Modes:

- | | |
|------------------------------------|---|
| • Standby/ Reset | Continuously variable standby level |
| • Static | Continuously variable static level |
| • Static + Dynamic | Continuously variable static level and dynamic level |
| • External Static Input | 10 K ohms input impedance
Positive polarity 0 - 10V |
| • External Dynamic Input | 10 K ohms input impedance
10 V peak AC |
| • Dither | 400 Hz +/- 10% |
| • Control Accuracy | 40 dB of full scale controlled variable |
| • Program Input Reference Signal | 1.0 VAC RMS +/- 50 MV - sinusoidal
5.0 V peak maximum - random |
| • Power Amp Input Reference Signal | 0 to 5 Volt Peak |
| • EXT Static Set Point | 0 to +5VDC for full scale operation |
| • EXT Dynamic Set Point | 0 to -5VDC for full scale operation |

7. Drawings

Printed Circuit Board Location	_____
Controller Schematic	D-015393
Block Diagram Master Controller (2 sheets)	D-015391
Schematic PCB 110-01 Sheet 3 - Load Cell Amp & Peak-Detector	C-015358
Schematic PCB 110-01 Sheet 1 - Static Loop	C-015358
Schematic PCB 110-01 Sheet 2 - Dynamic Loop	C-015358
PCB 110-01 (Component Location)	D-015384
Schematic PCB 110-02	C-014893
Assy PCB 110-02 (Component Location)	C-014881
Schematic PCB 110-04	C-010660
Assy PCB 110-04 (Component Location)	C-014882

8. Parts List

Xcite reserves the right to substitute parts without notice.

Component Part Number	Description
<u>Chassis</u>	
R301, 303, 307	1K, 10 Turn 5000 Series Pot
R302	50K, Trim Pot 3059J-1-503-M
R304, 311, 313	10K, Trim Pot 3059J-1-103-M
R305	Load Cell Dependent Phone Jack
R306	500 Ohm, Trim Pot 3059J-1-501-M
R308, 309, 310	47K, 1/2W, 5%
R312	110K, 1/4W, 5%
R314	100 Ohms, 1/4W, 5%
C301	50 MFD, 50V 7121L (39D)
T301, 302	Transformer, F-90X
T303	Supply, HAA-15-8
F301	Fuse, AGC 3, 3 amp
SW301	5A DPDT, 520-101G-51-A1H
SW302, 303	5A SPUT, 518-1016-51-A1H
SW304	Rotary 4P3T, 44A60-04-1-3N
SW305, 309, 311	4PDT Locking Toggle, MTL-406N
SW306, 312	DPDT Locking Toggle, MTL-206N
SW307, 308	SPDT Locking Toggle, MTL-106D
SW310	Rotary 5PDT, 71B30, 01-5-02N
M101, 102	100 Microamp, 4.5", 7045-3602-0000 API
J301, 302, 303	BNC Connector, UG-1094A/U
J304	Phone Jack, 12-B
J305	MS3102A-18-1S
J306	MS3102A-18-4S
J307	MS3102A-18-12P
J311	MS3102A-18-1P
KN301	Knob, DS70-2BD-2 (Rear)
KN302	Knob, DS70-3-2 (Front)

Component Part Number	Description
KN303, 304, 305	Dial, Turns Counting, 2606
L301	515-0012, Lamp, 6.5. Lamp Holder
L302	RA877 Crimp Lug
<u>PCB 110-01</u>	
R101, 102, 112, 176	10K, 1/4W, 5%
R103	47K, 1/4W, 5%
R104, 131, 135, 137, 138, 142, 151, 172	50K, Trim Pot, 784 Series
R105	30K, 1/4W, 5%
R106, 121, 122, 123, 126, 140, 141, 144, 145, 146, 147, 173, 177	100K, 1/4W, 5%
R107	1K, Trim Pot, 784 Series
R108	330 Ohm, 1/4W, 5%
R109	50K, Trim Pot
R110, 115, 116	Not used
R111, 134	1K, 1/4W, 5%
R113	470K, 1/4W, 5%
R114, 132	51K, 1/4W, 5%
R117	16K, 1/4W, 5%
R118	62K, 1/4W, 5%
R119, 120, 128, 129	20K, Trim Pot, 784 Series
R124, 133, 166	10K, Trim Pot, 784 Series
R125	24K, 1/4W, 5%
R127, 180	27K, 1/4W, 5%
R130	2.2M, 1/4W, 5%
R136, 143, 171, 175, 178	1M, 1/4W, 5%
R139	39K, 1/4W, 5%
*R148	240K, 1/4W, 5%
*R149	100K, 1/4W, 1%
*R150	510 Ohm, 1/4W, 5%
R152, 170	200 Ohm, 1/4W, 5%
R153	5K, Trim Pot, 784 Series
*R154, 182	10K, 1/4W, 5%
*R155, *158, *159, 160, 179	200K, 1/4W, 5%
R156, 157	20K, 1/4W, 5%
R161	1M, 1/4W, 1%
R162, 163	499 Ohms, 1/4W, 1%
R164, 165	100 Ohms, 1/4W, 5%
R167	100K, Trim Pot, 784 Series

Component Part Number	Description
R168	953K, 1/4W, 1%
R169	2.2K, 1/4W, 5%
R174	1M, 1/4W, 5%, Mod 4, 100K, 1/4W, 5%, Mod 2
*R181	30K, 1/4W, 5%
*R182	10K, 1/4W, 5%
R183	22K, 1/4W, 5%
R184	100K, 1/4W, 5%
R185	147K, 1/4W, 5%
C101	.68 MF Mod 4, .068 MF Mod 2
C102	.001 MF, 160-.015-20-400-C
C103, 110	Not Used
C104, 111, 112, 113	10 MF, 20V Dipped Tant.
C105	15 MF, 20V Dipped Tant.
C106	4.7 MF, 20V Dipped Tant.
C107, 114	1 MF, 20V Dipped Tant.
C108	4.7 MF, 100V 160-4.7-20-100-H (Mod 4 option only) (Not used for Mod 2)
C109	.68 MF, 100V 160-.68-20-100-D
C115	.0022 MF, 160-.0022-400-C
CR101, 102, 107	Not Used
CR103, *105, *106, *108	IN914
CR104	IN4737A
CR109	
U101	MC1494L
U102	AD536AJD
*U103	MC14013B
VR101	LM317LZ
A101, 105, *106	MC1458CP1
A102, 108	MC1741CP
A103, 104, 107	LF13741N
A109	LM308AN
K101	SPST, 360-12-1A
*Q101	MPSA13

Component Part Number**Description****PCB 110-02**

R201, 202	47 Ohm, 1/2W, 5%
R203	Not Used
R204	20K, 1/4W, 5%
R205	470K, 1/4W, 5%
R206, 209	1K, 1/4W, 5%
R207, 219, 222, 225	10K, 1/4W, 5%
R208, 212, 216, 221, 224	100K, 1/4W, 5%
R210	220K, 1/4W, 5%
R211	10K, 2W, 5%
R213, 214	820 Ohm, 1/4W, 5%
R215, 223	Not Used
R217, 218	10 Ohm, 1/2W, 5%
R220	3.6K, 1/4W, 5%
R226	1K, Trim Pot, 784 Series
R227	10K, 1/4W, 5%
R250	Valve Dependent, 1/4W, 5%
C201, 202	50 MF, 75V TVA-1343
C203, 205, 207	Not Used
C204	.047 MF, 160-.015-400-C
C206	.01 MF, 160-.01-630-C
C208	.033 MF, 160-.033-250-C
CR201 thru 211	IN5059
A201, 202	LF356N
K201, 202	Relay, 4PDT 1315-4C-12VDC
Q201	2N697
Q202	2N4036
Q203	2N3440
Q204	2N3441
Q205	2N5632
Q206	2N6229

Component Part Number**Description****PCB 110-04**

R401, 403, 405, 408, 416, 417, 418	Not Used
R402, 411	50K, Trim Pot, 784 Series
R404, 406, 426, 428	20K, 1/4W, 5%
R407	30K, 1/4W, 5%
R409, 413	1M, 1/4W, 5%
R410	100K, 1/4W, 5%
R412	10M, 1/4W, 5%
R414	140K, 1/4W, 5%
R415	47 Ohm, 1/4W, 5%
R419, 427	10K, 1/4w, 5%
R420, 421	39K, 1/4W, 5%
R422	470K, 1/4W, 5%
R423	4.7K, 1/4W, 5%
R424	4.3K, 1/4W, 5%
R425	8.2K, 1/4W, 5%
R429	15K, 1/4W, 5%
R430	6.2K, 1/4W, 5%
C401, 402	10 MF, 20V, Dipped Tant.
C403	68 MF, 20V, Dipped Tant.
C404	15 MF, 20V, Dipped Tant.
C405, 406	.01 MF, 160-.01-10-630-C
C407, 408	.1 MF, 160-.1-10-100-C
CR401, 402	N914
CR403	Not Used
CR404	IN5059
K401	Relay, 1310-4C-210AG
K402	Relay, 1315-4C-T2VDC
A401	MC1458CP
A402, 403, 404	LF356 or LM741

9. Calibration

The Xcite Master Controller is calibrated at the factory. Recalibration is required only if certain active components are replaced, or if a potentiometer is replaced.

Calibration need not be done in the order listed, nor are all adjustments required if one circuit is to be re-calibrated. Individual calibration may be performed as needed.

- Before beginning calibration, disconnect the head cable from J305.
- With power off, zero the static and dynamic meters, using the adjustment screw beneath each meter face.
- With power on but the pump off, check the following adjustments and readjust as described, if necessary. Place the following switches and controls in the positions given:

DITHER	OFF
STATIC SET POINT	0
DYNAMIC SET POINT	0
MODE CONTROL	STATIC
STATIC CONTROLLED VARIABLE	EXTERNAL
DYNAMIC CONTROLLED VARIABLE	EXTERNAL
TENSION/ COMPRESSION	COMPRESSION/ CCW

9.1. Equipment Needed

- 9.1.1. Stiff Test Structure (capable of w/standing the full rated force of the Exciter Head)
- 9.1.2. A 4 ½ digit Digital Multimeter
- 9.1.3. Oscilloscope
- 9.1.4. Signal Generator (audio frequency range)
- 9.1.5. FFT Spectrum Analyzer (if curves are to be run)
- 9.1.6. Trim pot adjustment tool or a small screwdriver

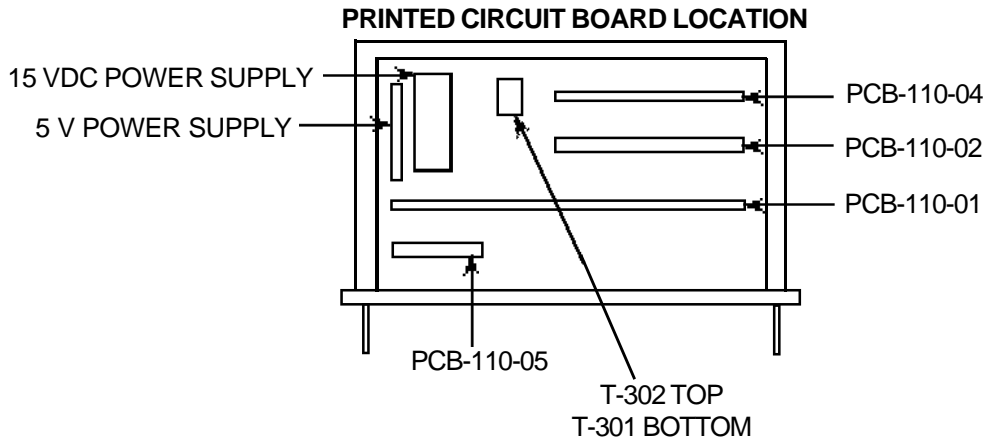

9.2. Master Controller

9.2.1. Meter Zero Adjustments

- Turn the Master Controller off.
- The Static and Dynamic meters should be resting precisely at zero.

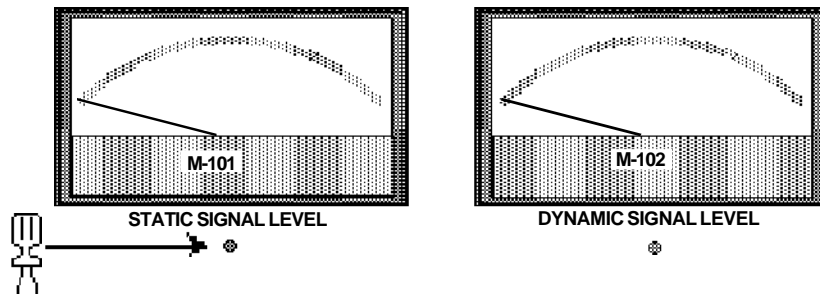

- If necessary, adjust the meters to zero using the small holes centered under each front panel meter.
- Turn the Master Controller on.

9.2.2. +/-15 Volt Supply Check

- Check for +15.00 Volts at 110-01-1 and -15.00 Volts at 110-01-3.
- If necessary adjust the supplies to within +/-10mV using the trim pots located on the power supply (mounted to the left rear of the chassis).

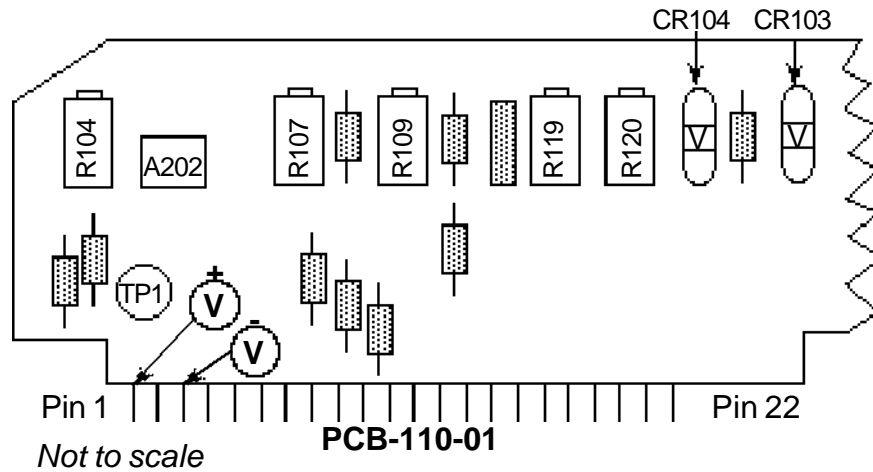

9.2.3. +/-60 Volt Supply Verification

Check for roughly +/-60 Volts at the large capacitors on the upper right corner of the 110-02 board. *No adjustment is possible.*

9.2.4. Load Cell Excitation Voltage Verification

Check for 12.0V +/- .3V at 110-01-44

9.2.5. Master Controller Board 110-04 Calibration Procedure

Initial Setup

Apply a shorted BNC cable or a 50Ω BNC terminator to the Program Input (J308).

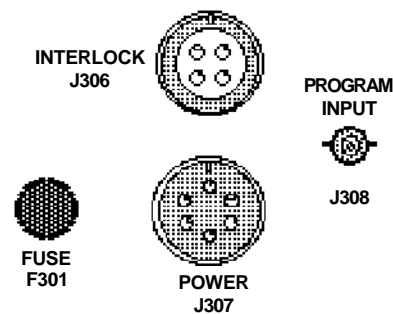

Program Input Offset Adjustment

Adjust R411 for 0mV at TP3.

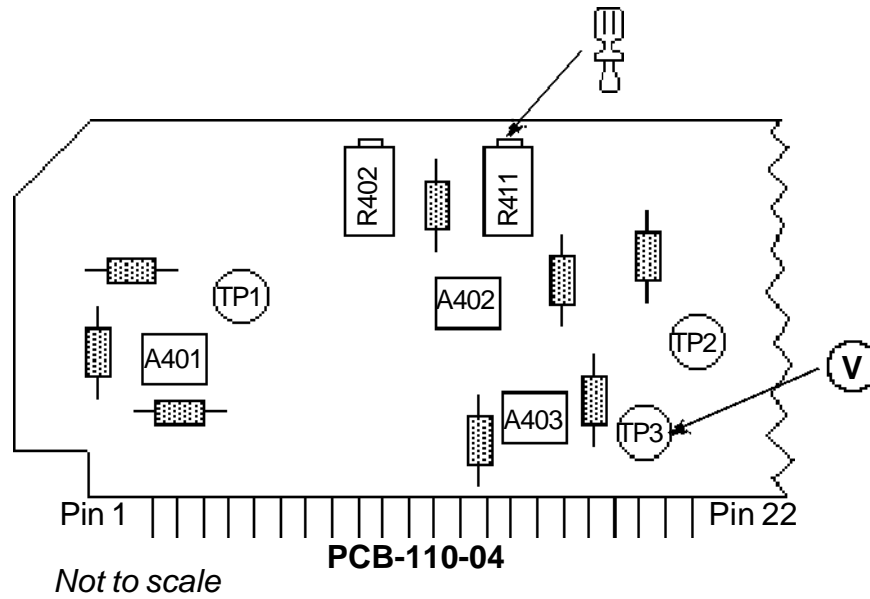

Dynamic Reference Offset Adjustment

Adjust R402 for 0mV at TP2.

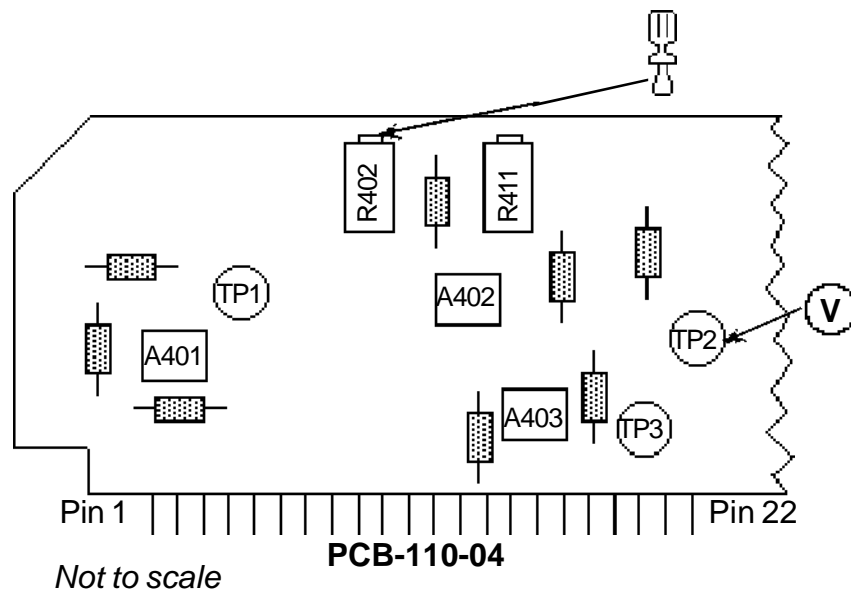

Dynamic Reference AC to DC Level Verification

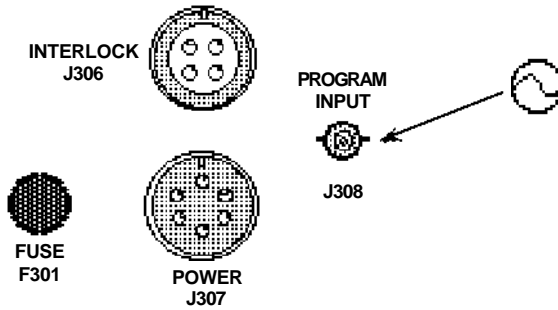

- Apply 1.000V rms to the Program Input (J308).
- Check for roughly -10.8V DC at TP2.
- Remove signal from the Program Input (J308).

Dither Oscillator Verification

Check for a 26V peak to peak, 360 Hz Triangle wave (+/-20 Hz) at TP4.

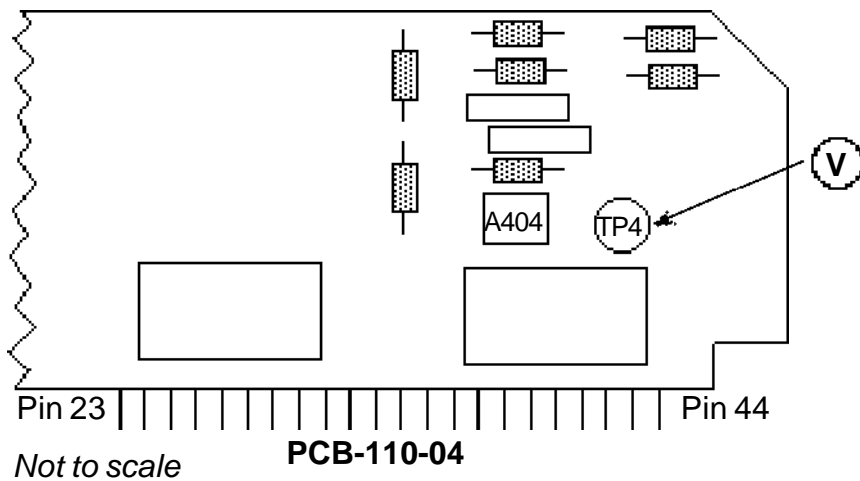

9.2.6. Master Controller Board 110-02 Calibration Procedure

Dither Level Calibration

- Set *DITHER* switch (SW308) to *ON*.
- Adjust R226 for 0.500V rms at 110-02-9.
- Set *DITHER* switch to *OFF*.

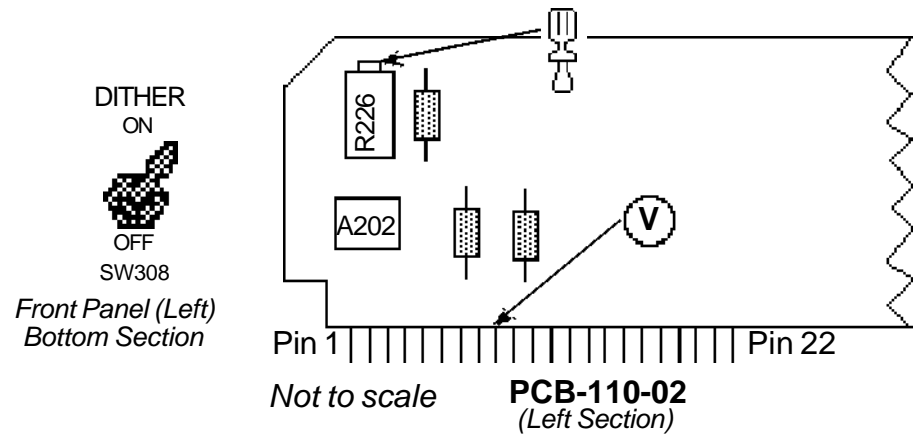

9.2.7. Master Controller Board 110-01 Calibration Procedure

Set front and rear panel switches and adjustments as follows:

Dither	(SW308)	Off
Load Cell Calibrate/ Operate	(SW307)	Operate
Frequency	(SW309)	Low
Power Amp Input	(SW312)	Internal
Static Preload	(SW310)	Compression
Static Controlled Variable	(SW311)	External
Dynamic Controlled Variable	(SW306)	External
Static Gain	(SW305)	Fixed
Standby Level	(R313)	Full CCW
Static Set Point Level	(R301)	0.0
Dynamic Set Point Level	(R303)	0.0
Static Gain Level	(R307)	5.0

External Static and Dynamic Variable Input Calibration

- Apply a 1.000V rms, 100 Hz sine wave to the External Static Variable Input (J309).
- Adjust External Static Cal (R311) for .500V rms at 110-01-28 (WHT/ RED wire).
- Apply a 1.000V rms, 100 Hz sine wave to the External Dynamic Variable Input (J302).
- Adjust External Dynamic Cal (R304) for .500V rms at 110-01-25 (WHT/ BLK wire).
- Remove signal

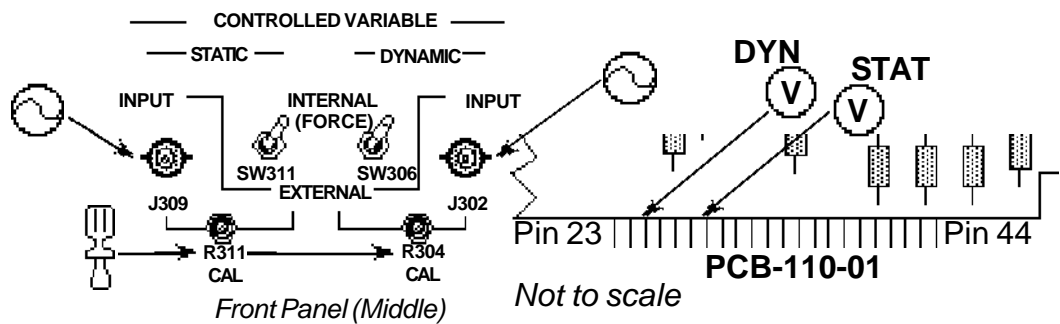

Load Cell Amplifier Common Mode Null Adjustment

- Apply a 1.000V rms, 100 Hz sine wave to 110-01-39 (BLK wire) and 110-01-41(SILVER wire).
- Adjust R167 for minimum 100 Hz signal at TP9.
- Remove signal from 110-01-39 and 110-01-41.

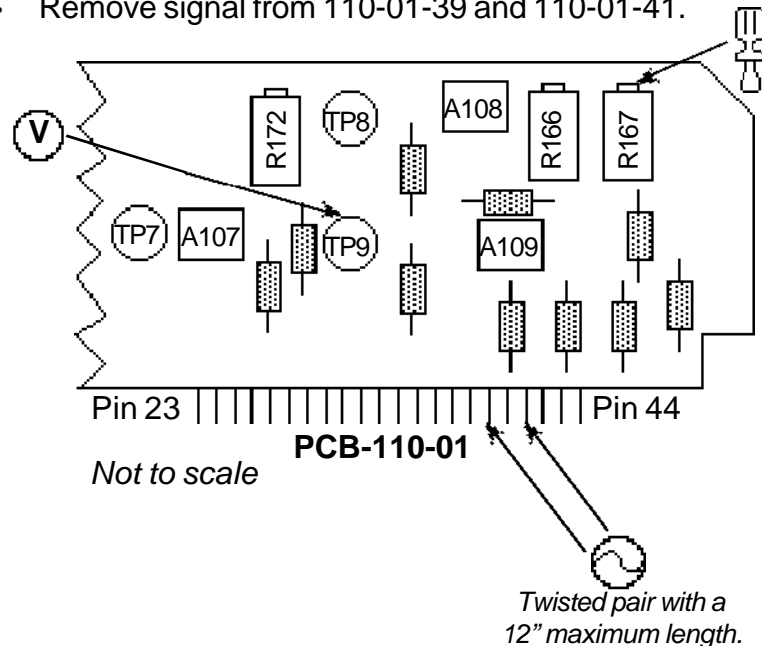

Meter Amplifier Zero Offset Adjustments

With no signals applied, make the following settings:

Static Set Point Level	(R301)	0.0
Dynamic Set Point Level	(R303)	0.0
Static Controlled Variable	(SW311)	External
Dynamic Controlled Variable	(SW306)	External

- Adjust (Static Offset) R142 for 0mV at TP6.
- Adjust (Dynamic Offset) R131 for 0mV at TP3.

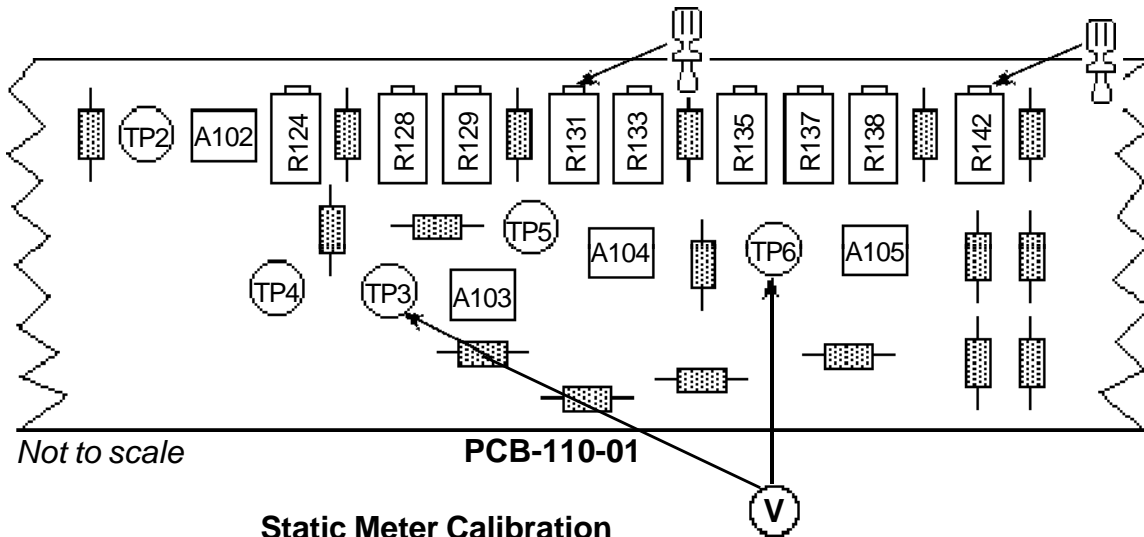

Static Meter Calibration

- Apply 5.000V DC at 110-01-28 (WHT/ RED wire).
- Adjust R138 to set Static Meter deflection at 100%.
- Remove signal from 110-01-28.

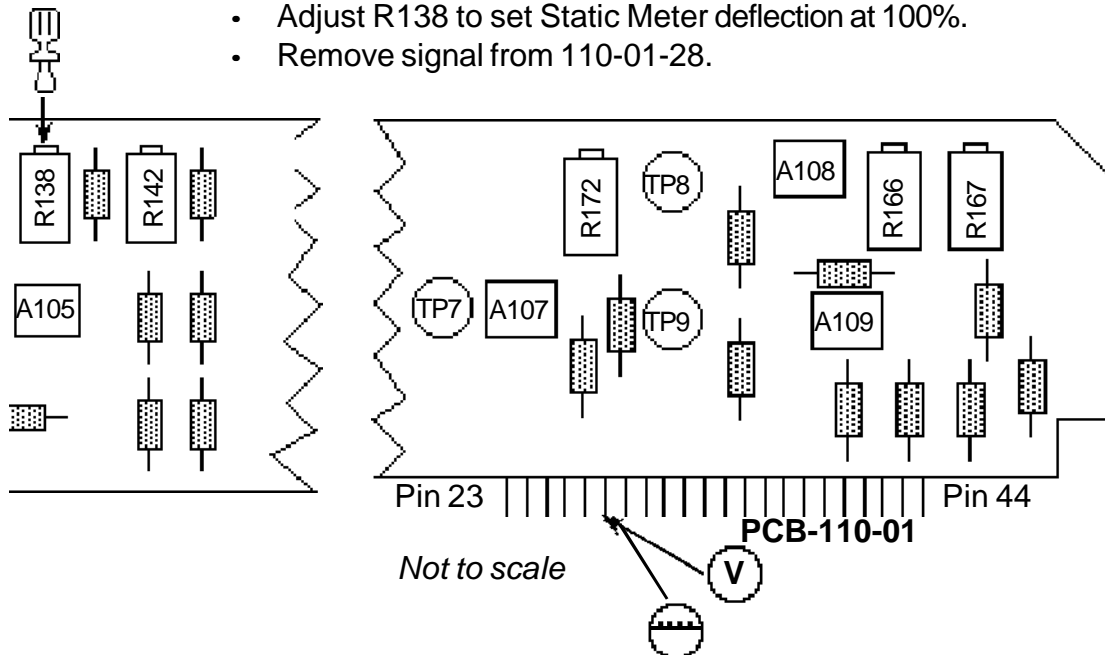

Dynamic Meter Calibration

Pre RMS Converter Check

- Set the Dynamic Control Variable (SW306) to External.
- Apply a 100 Hz sine wave to the Dynamic Variable Input (J302).
- Adjust Signal level for 1.000V rms at 110-01-25 (WHT/ BLK wire).
- Check for an inverted 1.0V rms +/-5% signal at TP3.

RMS Converter Check

Check for 1.00V DC at TP4.

Dynamic Meter Calibration Adjustment

- Adjust the signal level for 1.77V rms at 110-01-25 (WHT/BLK wire).
- Adjust R129 for 50% full scale deflection of Dynamic Meter.
- Remove signal from Dynamic Variable Input (J302).

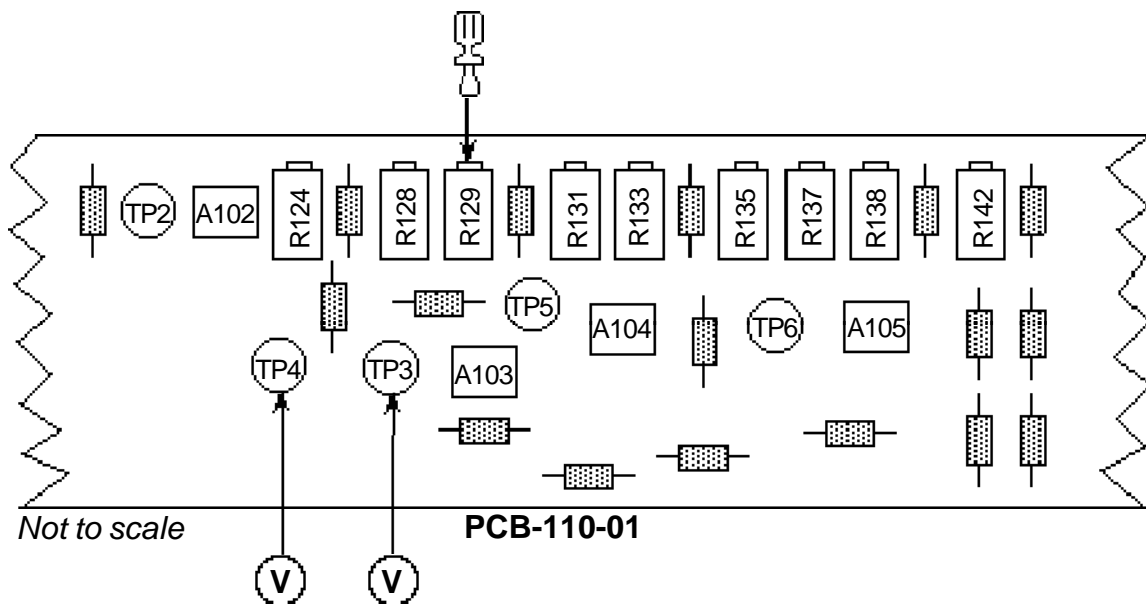
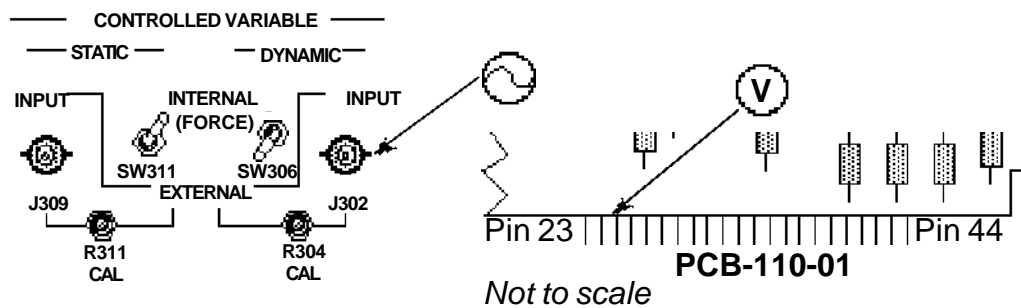

Dynamic Multiplier Calibration

Integrator Bias Calibration

Adjust R124 for -10mV DC at TP2.

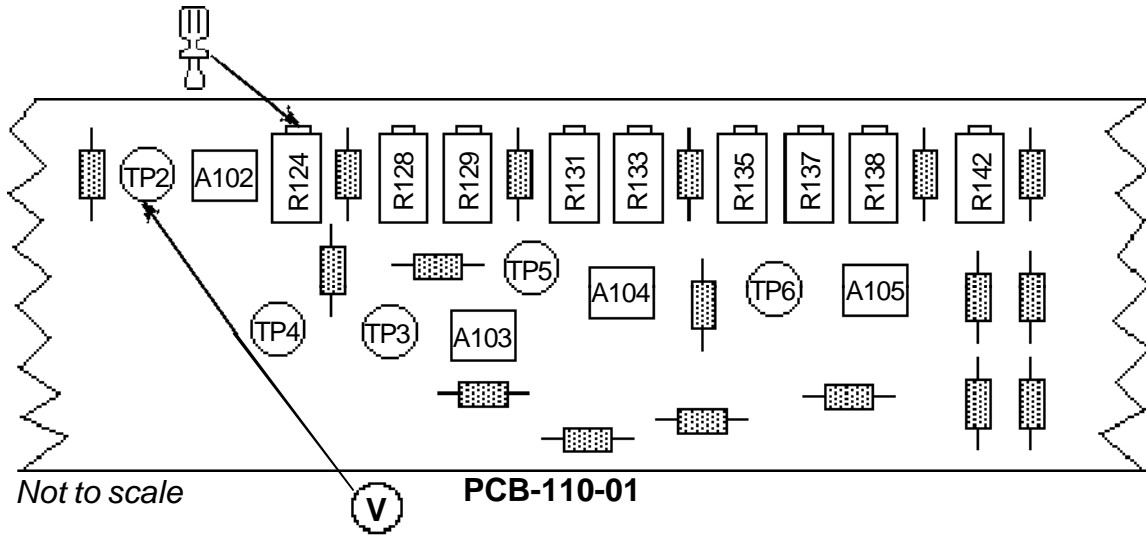

P-Clip Adjustment

Adjust R109 fully clockwise (to Maximum).

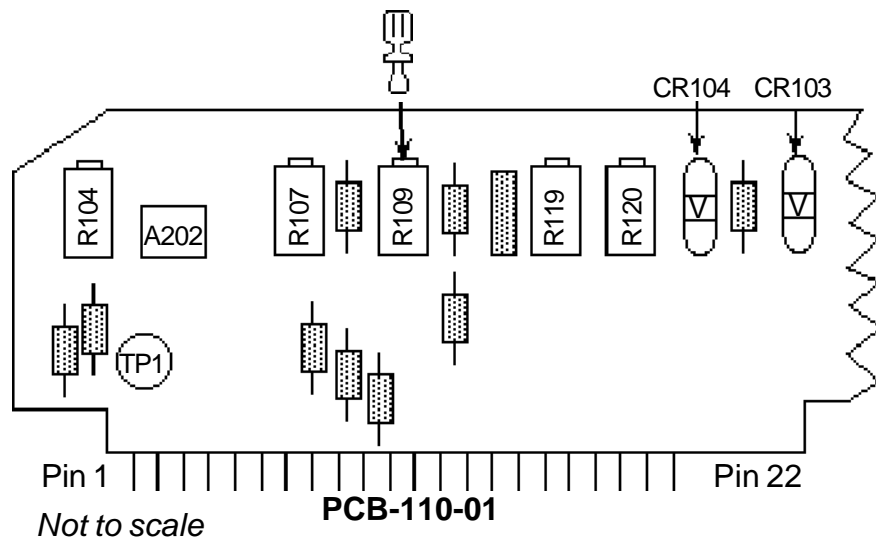

Initial Multiplier Offset Adjustment

Adjust R104 for 0mV DC +/-100mV at TP1.

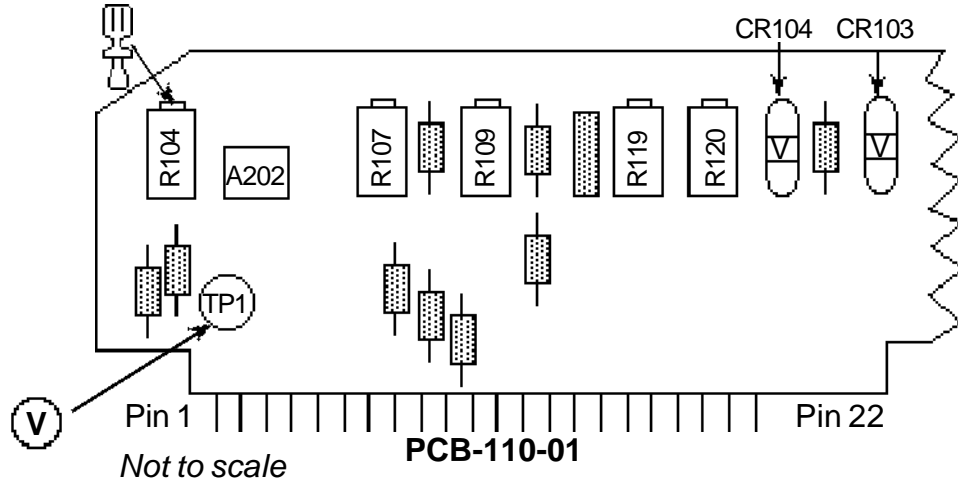

Multiplier X Input Null

- Apply a 1.0V rms, 120 Hz sine wave to the Cathode side of CR104.
- Adjust R119 for minimum 120 Hz signal at TP1.

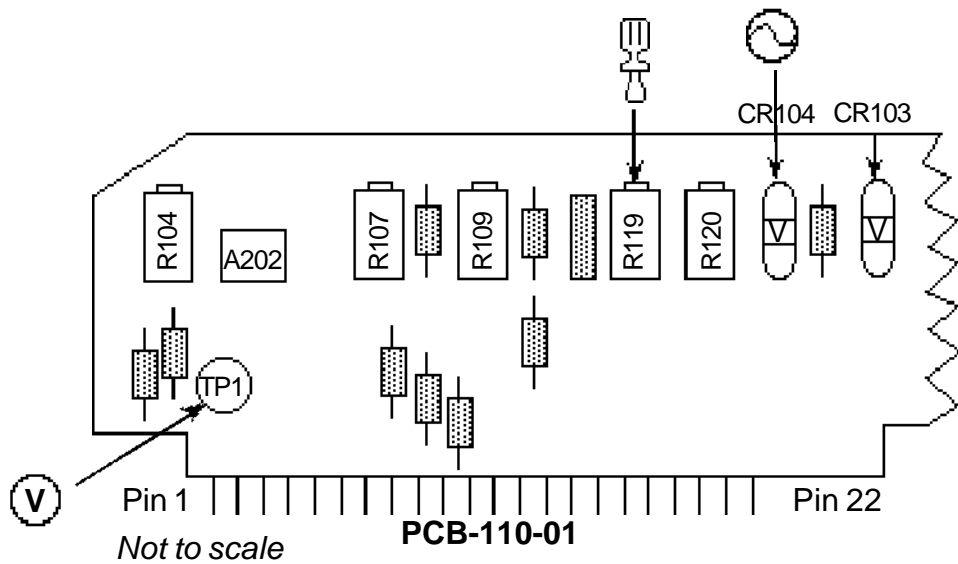

Multiplier Y Input Null

- Remove the signal from CR104.
- Apply a 1.0V rms, 120 Hz sine wave to the Program Input (J308).
- Adjust R120 for minimum 120 Hz signal at TP1.

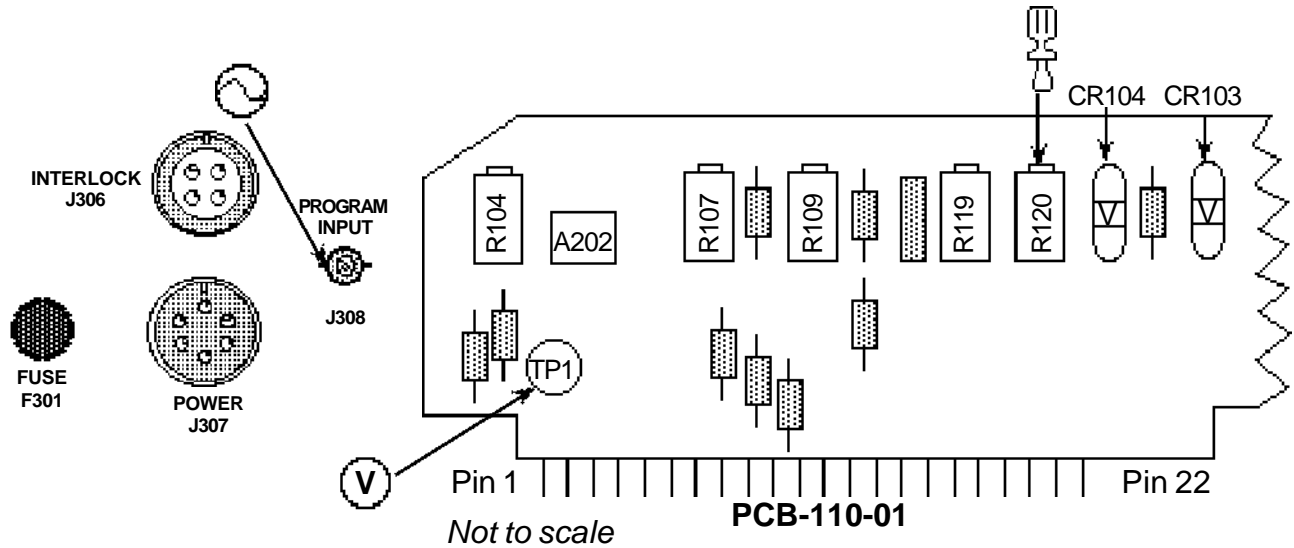

NOTE: Steps 2.4.7.4. and 2.4.7.5. may be slightly interactive. Repeat both adjustments until both inputs are nulled.

Final Multiplier Offset Adjustment

- Remove signal generator.
- Adjust R104 for 0mV +/-10mV at TP1.

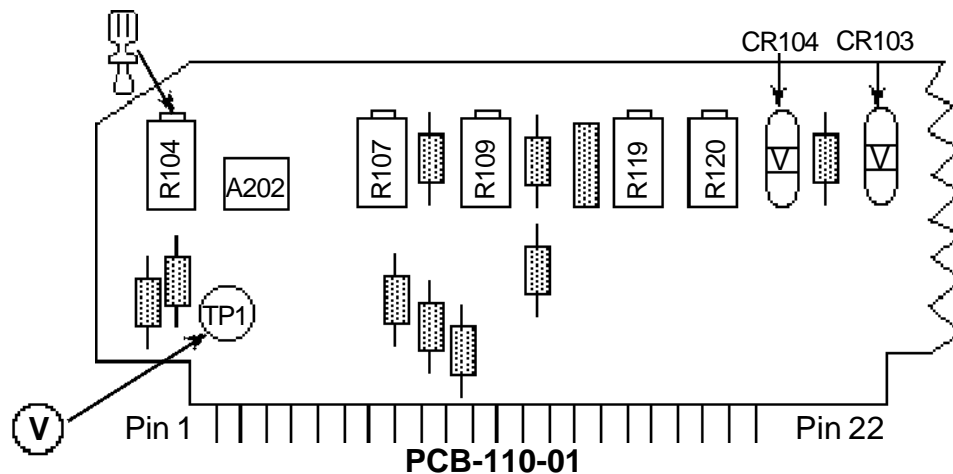

9.3. Exciter Head Calibration Procedure

Set front and rear panel switches and adjustments as follows:

Dither	(SW308)	Off
Load Cell Calibrate/ Operate	(SW307)	Operate
Frequency	(SW309)	Low
Power Amp Input	(SW312)	Internal
Static Preload	(SW310)	Compression
Static Controlled Variable	(SW311)	Internal
Dynamic Controlled Variable	(SW306)	Internal
Static Gain	(SW305)	Variable
Standby Level	(R313)	Full CCW
Static Set Point Level	(R301)	8.0
Dynamic Set Point Level	(R303)	5.0
Static Gain Level	(R307)	5.0

9.3.1. Load Cell Amplifier Calibration

Initial Setup

- Connect P305 end of the Controller Cable to J305 (Rear Panel).
- Connect the 4-pin cable to the load cell.
- Insert the Cal Plug into J304.

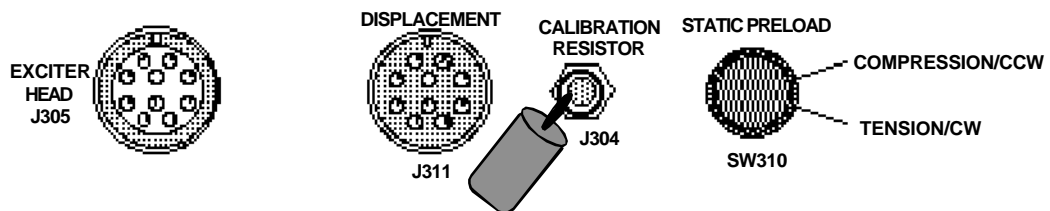

NOTE: The following two adjustments are very interactive; it will be necessary to repeat both adjustments until an acceptable balance is achieved.

Adjust Load Cell Zero Calibration

- Set the Load Cell Operate/ Calibrate Switch (SW307) to *OPERATE*.
- Adjust the Load Cell Zero (R302) for 0mV at TP8 or *LOAD CELL* outputs on Front or Rear Panel (J301 or J303).

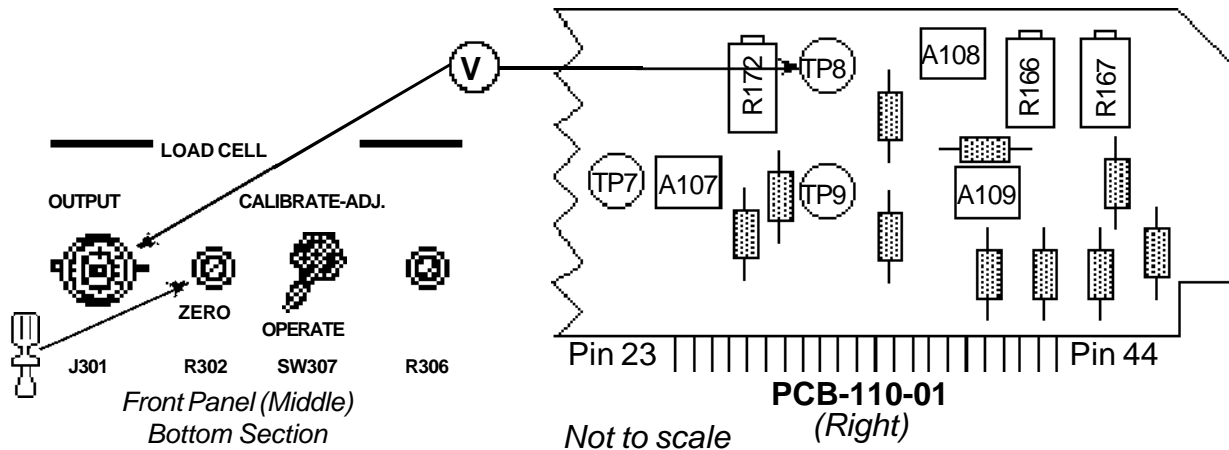

Load Cell Meter Calibration

- Set Load Cell Operate/ Calibrate Switch (SW307) to *CALIBRATE*.
- Adjust the Load Cell Calibration (R306) until the Static Meter reads the Force value (expressed in lbs or Kg) that is supplied on the Load Cell Cal Plug.

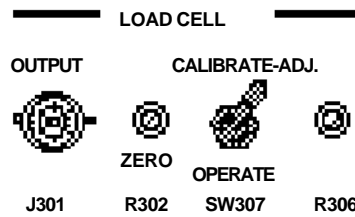

- Repeat Load Cell Zero and Load Cell Meter Calibration until calibration and zero balance is achieved.
- When finished leave the Load Cell Operate/ Calibrate Switch in the *OPERATE* position.

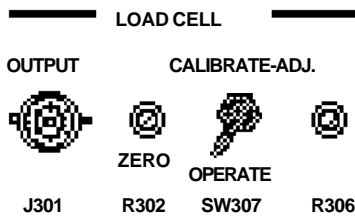

Load Cell Amplifier Scaling

Adjust R166 for Load Cell Calibration voltage at TP8 or *LOAD CELL OUT* using the following formula to determine values:

$$[\text{Calibration Force (on Cal Plug)}/\text{Sens (on Cal Plug)}]$$

Examples:

$$[357\text{lbs per } 300\Omega / 250\text{lbs per Volt}]$$

$$= 1.428 \text{ Volts per } 300 \text{ K}\Omega$$

$$\frac{2558 \text{ Kg}}{1000 \text{ Kg/V}} = 2.558\text{V}$$

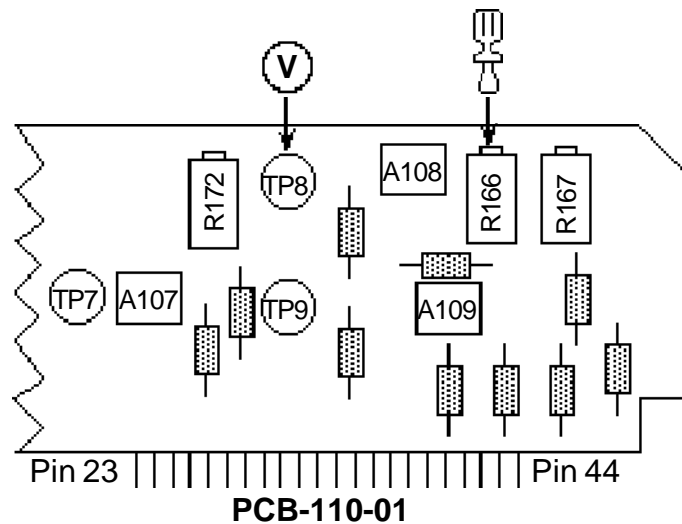

Not to scale

9.3.2. Static Loop Gain Calibration

Set the front and rear panel switches and adjustments as follows:

Excitation Mode Switch	(SW304)	Standby
Load Cell Calibrate/ Operate	(SW307)	Operate
Frequency	(SW309)	Low
Static Preload	(SW310)	Compression
Static Controlled Variable	(SW311)	Internal
Dynamic Controlled Variable	(SW306)	Internal
Static Gain	(SW305)	Variable
Static Set Point Level	(R301)	8.0
Dynamic Set Point Level	(R303)	5.0
Static Gain Level	(R307)	5.0

- Fixture the exciter head for compression into a rigid structure.
- Connect J305, J311, J309 (with BNC Pigtail to static variable input).
- Connect cables to the exciter head.
- Apply a 1.00V peak-peak, 5 Hz square wave to the Program Input (J308).

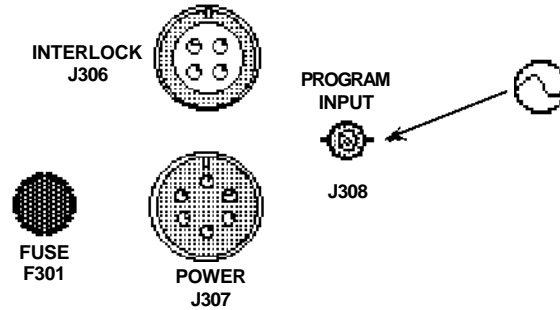

- Start the Hydraulic Supply.
- Set the Excitation Mode Switch (SW304) at *STATIC + DYNAMIC*.
- Adjust Dynamic Setpoint for 1 Volt Plateau to Plateau then adjust (R133) for 20% overshoot (1.2 volts Peak to Peak - as illustrated below). Measure at Load Cell output BNC on Front Panel.

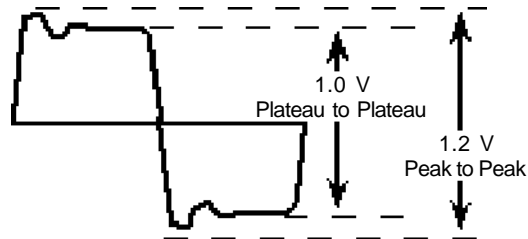

20% overshoot Square wave response for optimum Static Gain Setting.

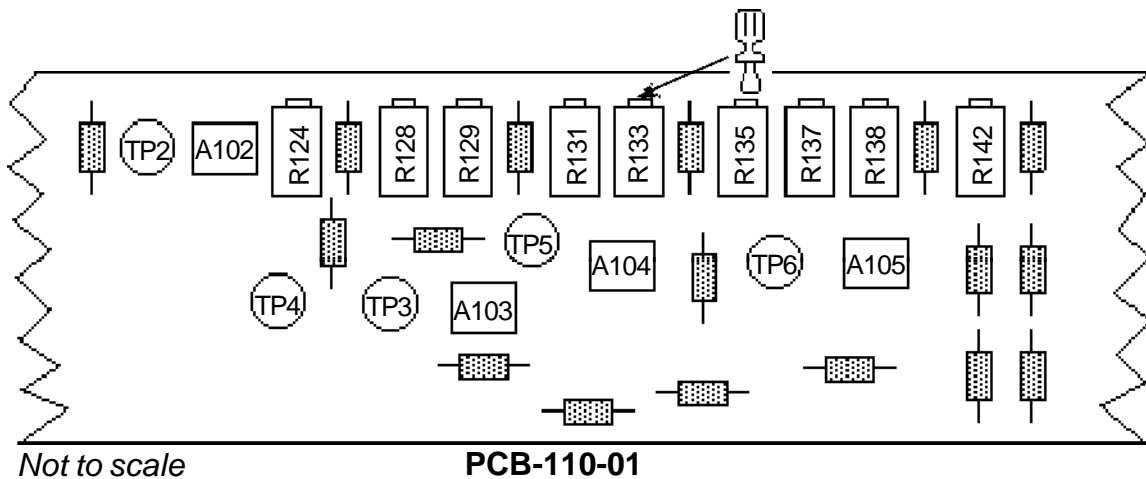

9.3.3. Static Set Point Level Calibration

Set front and rear panel switches and adjustments as follows:

Excitation Mode Switch	(SW304)	Static
Static Gain	(SW305)	Fixed
Static Gain Level	(R307)	5.0
Static Set Point Level	(R301)	5.0

- Adjust R107 (Static Cal) for a 50% Static Meter Reading.

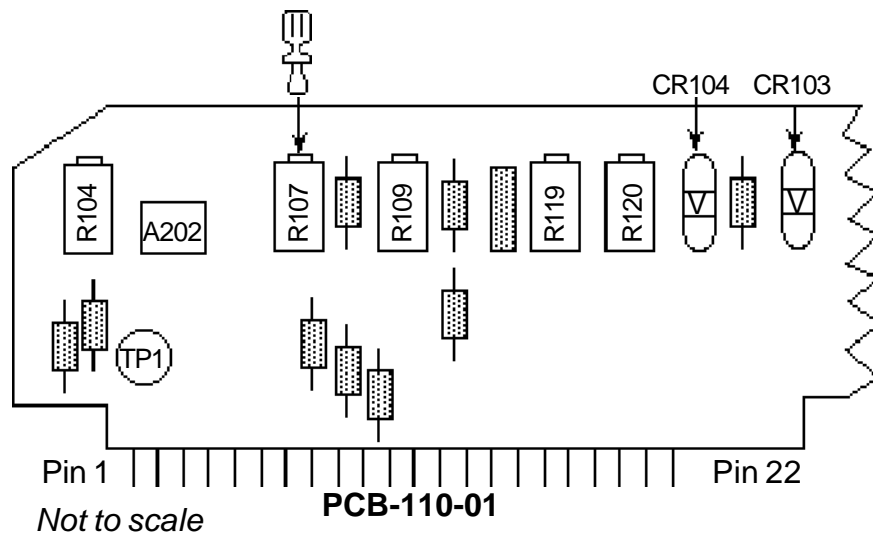
**9.3.4. High Frequency Dynamic Level Calibration**

Set front and rear panel switches and adjustments as follows:

Load Cell Calibrate/ Operate	(SW307)	Operate
Frequency	(SW309)	High
Static Gain	(SW305)	Fixed
Static Set Point Level	(R301)	8.0
Dynamic Set Point Level	(R303)	5.0

- Apply a 1.000V rms, 60 Hz sine wave to the Program Input (J308).
- Set the Excitation Mode Switch (SW304) to the *STATIC + DYNAMIC* position.
- Adjust R128 for a 50% Dynamic Meter reading (1.77V rms at 110-01-25).

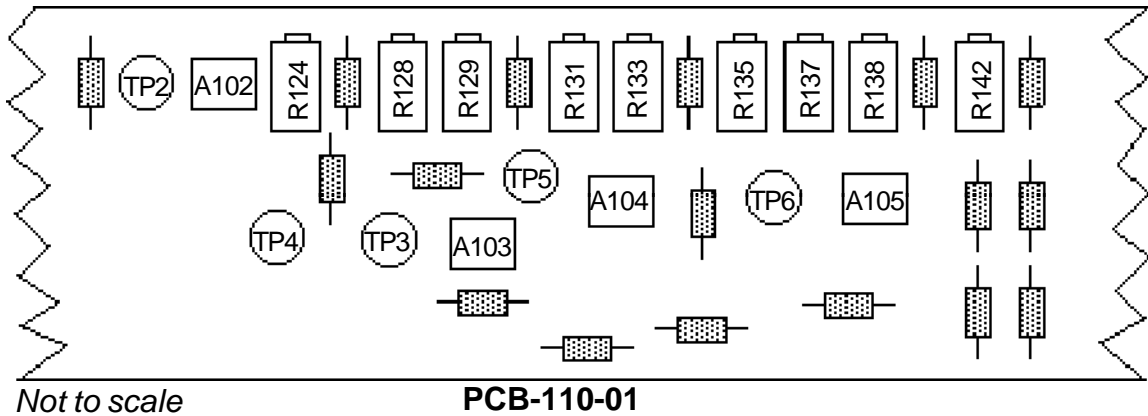

9.3.5. Low Frequency Dynamic Calibration

Set front and rear panel switches and adjustments as follows:

Load Cell Calibrate/ Operate	(SW307)	Operate
Frequency	(SW309)	Low
Static Gain	(SW305)	Fixed
Static Set Point Level	(R301)	8.0
Dynamic Set Point Level	(R303)	5.0

- Apply a 1.000V rms, 10 Hz sine wave to the Program Input (J308).
- Set the Excitation Mode Switch (SW304) to the *STATIC + DYNAMIC* position.
- Adjust R137 for a 50% Dynamic Meter reading (1.77V rms at 110-01-25).

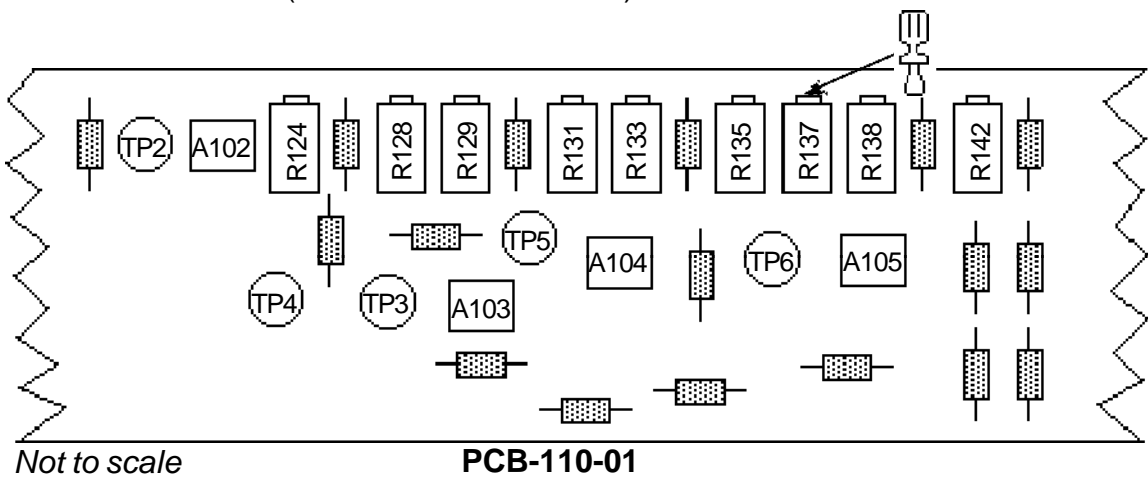

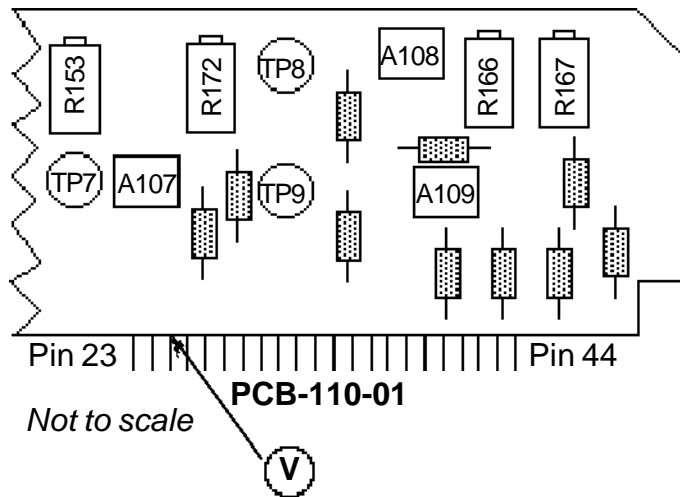

9.4. Displacement Calibration Procedure

Note: Fixture Exciter head for full Stroke.

9.4.1. LVDT Symmetry Verification and Adjustment

Set front and rear panel switches and adjustments as follows:

Excitation Mode	(SW304)	Standby/ Reset
Load Cell Calibrate/ Operate	(SW307)	Operate
Frequency	(SW309)	Low
Static Preload	(SW310)	Compression
Static Controlled Variable (Disconnect Displacement		
Feedback Signal for this set up)	(SW311)	External
Static Gain	(SW305)	Variable
Static Set Point Level	(R301)	10.0
Static Gain Level	(R307)	5.0

- Set the Static Preload Switch (SW310) to *TENSION* (CW). The head should fully extend.
- Set the Static Preload Switch to *COMPRESSION* (CCW). The head should fully retract.
- While monitoring 110-01-38 (WHT/ YEL wire) with a DC volt meter, you should observe a **NEGATIVE** voltage when the head is fully extended and a **POSITIVE** voltage when the head is retracted. These two voltages should be equal and opposite in magnitude.

NOTE: The importance is in the equality of the numerical values not in their values. (i.e. +3 and -3 are just as good as +6 and -6)

- If the balance is off by more than 10%, the LVDT Rod or the position of the LVDT on the Exciter Head should be adjusted.

WARNING

Do not make mechanical adjustments to an exciter head while the hydraulic power supply is active. Serious personal injury could result.

9.4.2. Displacement Zero Calibration

- Set the Static Setpoint (R301) to 10.0.
- Set the Excitation Mode switch (SW304) to *STATIC*.
- Set the Static Preload switch (SW310) to *TENSION*. The head should fully retract.
- Adjust R172 for 0mV at TP7.

9.4.3. Displacement Scaling Calibration

- Set the STATIC PRELOAD SWITCH (SW310) to *COMPRESSION*. The head should be fully extended.
- Adjust R153 for 10.000V at TP7.
- The static meter should read 100% full scale deflection.
- Repeat steps 4.2. and 4.3. until balance is achieved.

9.4.4. Final External Static Control Variable Calibration

- Verify 10.000V DC at TP7 (accurate to within 1.0mV)
- If necessary, adjust the Static Variable Cal (R311) for 0.5V DC at 110-01-28

9.4.5. Dynamic Displacement Calibration

Set front and rear panel switches and adjustments as follows:

Frequency	(SW309)	Low
Power Amp Input	(SW312)	Internal
Static Preload	(SW310)	Compression
Static Controlled Variable	(SW311)	External
Dynamic Controlled Variable	(SW306)	Internal
Static Gain	(SW305)	Variable
Static Set Point Level	(R301)	5.0
Dynamic Set Point Level	(R303)	5.0
Static Gain Level	(R307)	5.0

- Set the Excitation Mode Switch (SW304) to the *STATIC + DYNAMIC* position.
- Apply a 1V rms, 5 Hz sine wave to the Program Input (J308).
- Adjust R135 for a 5V peak-peak at TP7.

9.4.6. External Static and Dynamic Set Point Calibration

There are no adjustments or calibrations for the External Static and Dynamic Set Point inputs. Verify that the static controlled variable achieves full scale output with a +5VDC, +/-5% signal and that the dynamic controlled variable achieves full scale output with a -5VDC, +/-5% signal.