

GLASS TYPE 'A'
7/16" OVERALL LAM. GLASS

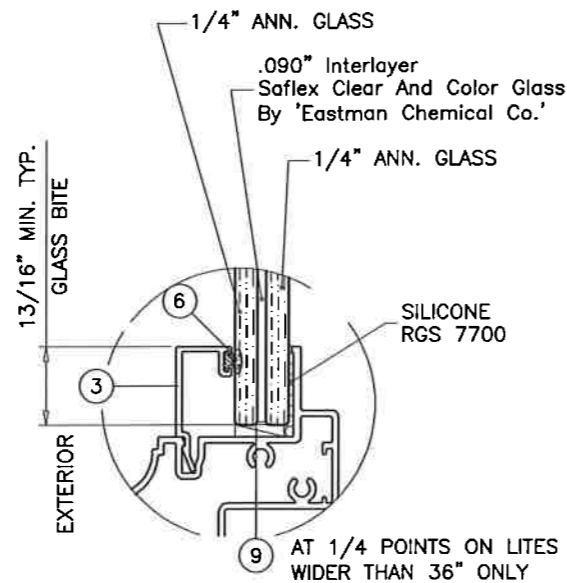

GLASS TYPE 'B'
9/16" OVERALL LAM. GLASS

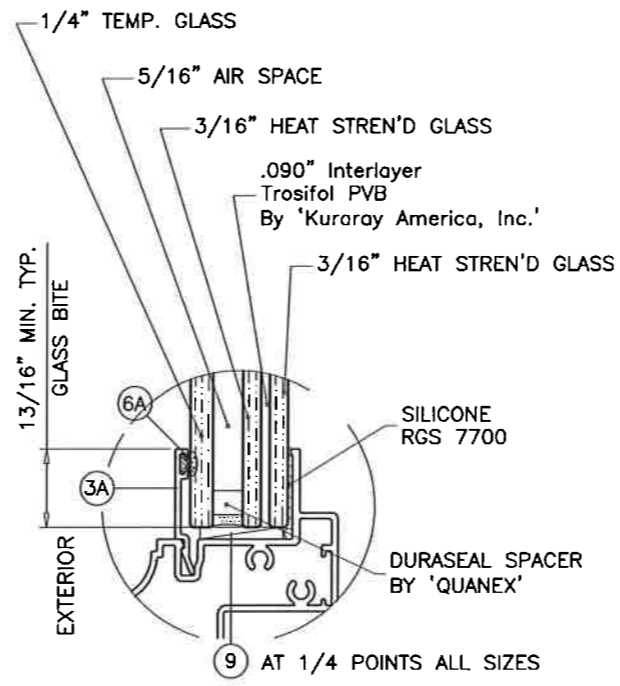

GLASS TYPE 'C'
1" OVERALL INSUL. LAM. GLASS

GLAZING OPTIONS

THESE WINDOWS ARE RATED FOR LARGE & SMALL MISSILE IMPACT. SHUTTERS ARE NOT REQUIRED.

**SERIES 525
ALUMINUM CASEMENT WINDOW**

APPROVAL APPLIES TO SINGLE UNITS OR SIDE BY SIDE COMBINATIONS OF CASMT/CASMT OR CASEMENT WITH OTHER F.B.C. APPR'D WINDOWS USING F.B.C. APPROVED MULLIONS IN BETWEEN. LOWER DESIGN PRESSURE FROM WINDOWS OR MULLION APPROVAL WILL APPLY TO ENTIRE SYSTEM.

THIS PRODUCT HAS BEEN DESIGNED AND TESTED TO COMPLY WITH THE REQUIREMENTS OF THE 2014 (5TH EDITION)/2017 (6TH EDITION) FLORIDA BUILDING CODE INCLUDING HIGH VELOCITY HURRICANE ZONE (HVHZ).

1BY OR 2BY WOOD BUCKS & BUCK FASTENERS BY OTHERS, MUST BE DESIGNED AND INSTALLED ADEQUATELY TO TRANSFER APPLIED PRODUCT LOADS TO THE BUILDING STRUCTURE.

ANCHORS SHALL BE CORROSION RESISTANT, SPACED AS SHOWN ON DETAILS AND INSTALLED PER MANUF'S INSTRUCTIONS. SPECIFIED EMBEDMENT TO BASE MATERIAL SHALL BE BEYOND WALL DRESSING OR STUCCO.

A LOAD DURATION INCREASE IS USED IN DESIGN OF ANCHORS INTO WOOD ONLY.

ALL SHIMS TO BE HIGH IMPACT, NON-METALLIC AND NON-COMPRESSIBLE.

MATERIALS INCLUDING BUT NOT LIMITED TO STEEL/METAL SCREWS, THAT COME INTO CONTACT WITH OTHER DISSIMILAR MATERIALS SHALL MEET THE REQUIREMENTS OF THE 2014/2017 FLORIDA BLDG. CODE & ADOPTED STANDARDS.

THIS PRODUCT APPROVAL IS GENERIC AND DOES NOT PROVIDE INFORMATION FOR A SITE SPECIFIC PROJECT, I.E. LIFE SAFETY OF THIS PRODUCT, ADEQUACY OF STRUCTURE RECEIVING THIS PRODUCT AND SEALING AROUND OPENING FOR WATER INFILTRATION RESISTANCE ETC. CONDITIONS NOT SHOWN IN THIS DRAWING ARE TO BE ANALYZED SEPARATELY, AND TO BE REVIEWED BY BUILDING OFFICIAL.

MANUFACTURER'S LABEL SHALL BE LOCATED ON A READILY VISIBLE LOCATION IN ACCORDANCE WITH SECTION 1709.9.3 OF FLORIDA BUILDING CODE. LABELING TO COMPLY WITH SECTION 1709.9.2.

NOTE:
GLASS CAPACITIES ON THIS SHEET ARE BASED ON ASTM E1300-09 (3 SEC. GUSTS) AND FLORIDA BUILDING COMMISSION DECLARATORY STATEMENT DCA05-DEC-219

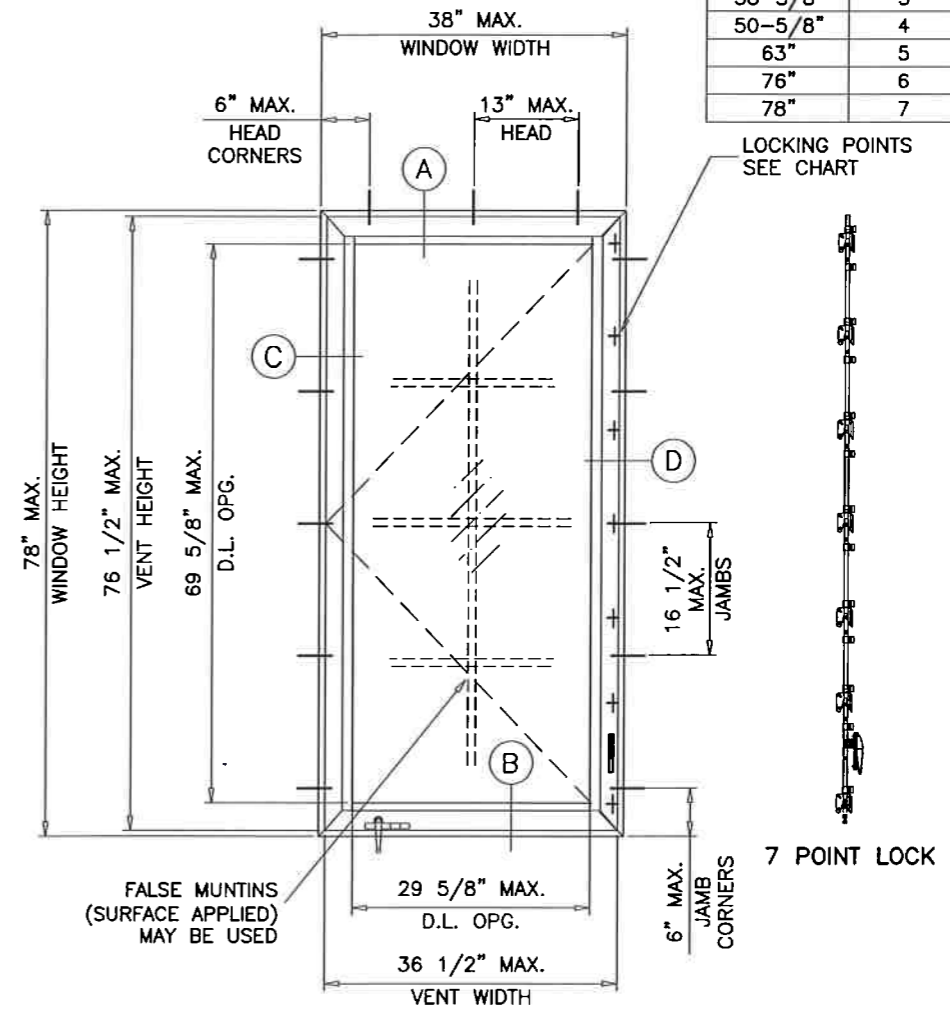

TYPICAL ELEVATION

GLASS TYPES 'A', 'B' OR 'C'
MAXIMUM DESIGN LOAD RATING = + 70.0 PSF
(FOR SIZES SHOWN ABOVE OR SMALLER) - 75.0 PSF

DAYLITE OPENINGS:
D.L.O. HEIGHT = WINDOW HEIGHT - 8.375"
D.L.O. WIDTH = WINDOW WIDTH - 8.375"
VENT HEIGHT = WINDOW HEIGHT - 1.50"
VENT WIDTH = WINDOW WIDTH - 1.50"

WDW. HEIGHT UPTO	NO. OF KEEPERS AT SASH
26"	2
38-3/8"	3
50-5/8"	4
63"	5
76"	6
78"	7

LOCKING POINTS SEE CHART

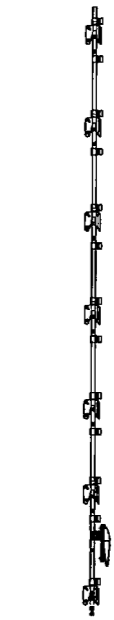

7 POINT LOCK

A- CONTRACTOR TO BE RESPONSIBLE FOR THE SELECTION, PURCHASE AND INSTALLATION OF THIS PRODUCT BASED ON THIS PRODUCT EVALUATION PROVIDED HE/SHE DOES NOT DEVIATE FROM THE CONDITIONS DETAILED ON THIS DOCUMENT.
B- THIS PRODUCT EVALUATION DOCUMENT WILL BE CONSIDERED INVALID IF ALTERED BY ANY MEANS.
C- SITE SPECIFIC PROJECTS SHALL BE PREPARED BY A FLORIDA REGISTERED ENGINEER OR ARCHITECT WHICH WILL BECOME THE ENGINEER OF RECORD (E.O.R.) FOR THE PROJECT AND WHO WILL BE RESPONSIBLE FOR THE PROPER USE OF THE P.E.D. ENGINEER OF RECORD, ACTING AS A DELEGATED ENGINEER TO THE P.E.D. ENGINEER SHALL SUBMIT TO THIS LATTER THE SITE SPECIFIC DRAWINGS FOR REVIEW.
D- THIS P.E.D. SHALL BEAR THE DATE AND ORIGINAL SEAL AND SIGNATURE OF THE PROFESSIONAL ENGINEER OF RECORD THAT PREPARED IT.

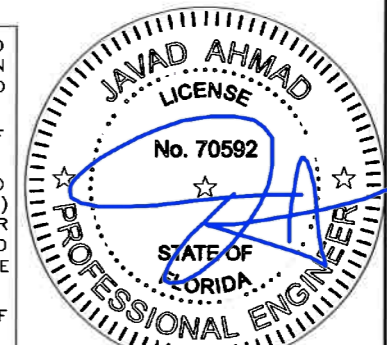

FL #21898

AL-FAROOQ CORPORATION
ENGINEERS & PRODUCT DEVELOPMENT
9360 SUNSET DRIVE, SUITE 220
MIAMI, FLORIDA 33173
TEL. (305) 264-8100 FAX. (305) 262-6978

SERIES 525 ALUMINUM CASEMENT WDW. (L.M.I.)
Assura Windows & Doors, LLC.
1543 N. Powerline Road
Pompano Beach, Fl. 33069
Tel. (305) 887-2646 Fax. (-)

revisions:	no.	date	by	description
	A	10.09.17		UPDATED TO 2017 FBC

date: 02-10-17
scale: 1/2" = 1'-0"
dr. by: TARIQ
chk. by:

drawing no.
W17-20
sheet 1 of 5

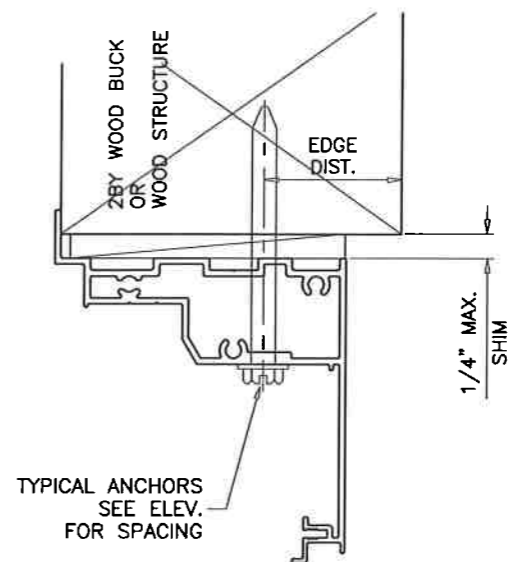
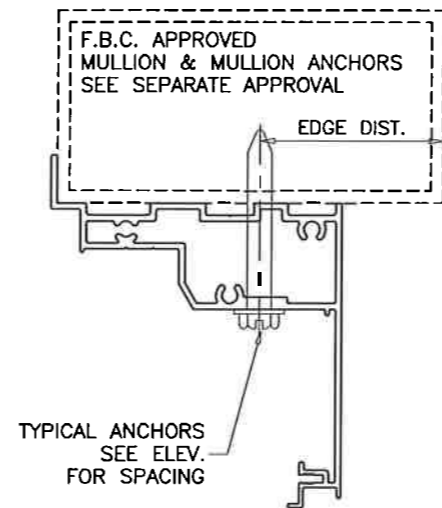
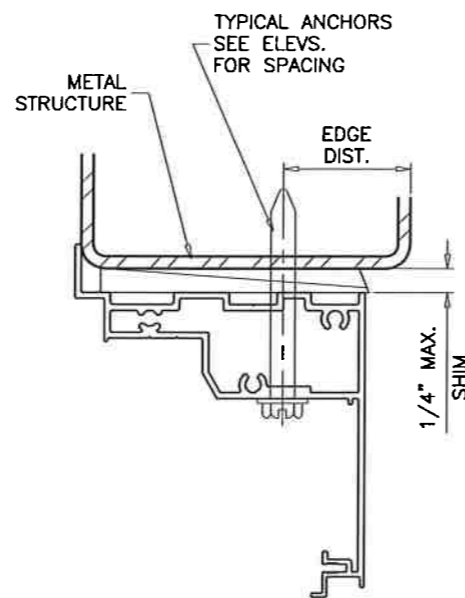
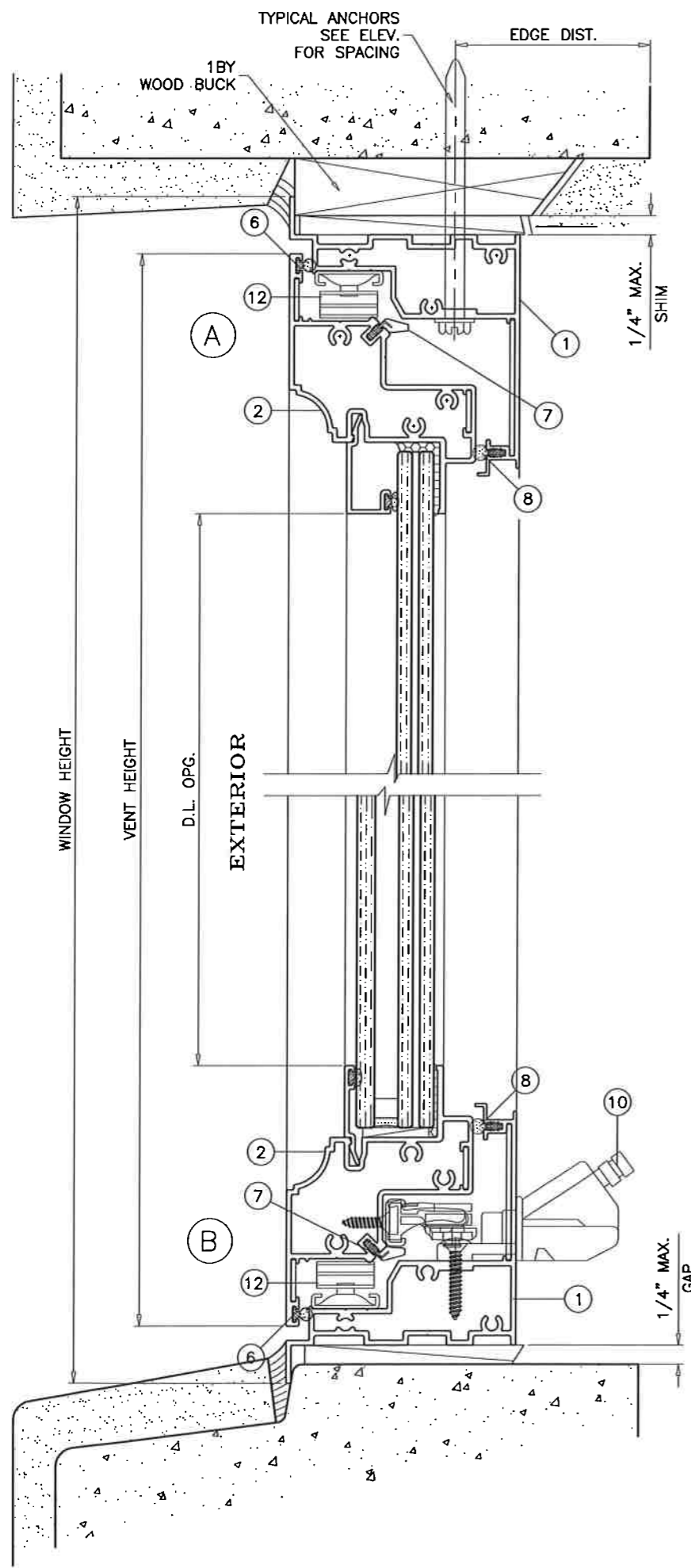

WOOD BUCKS AND METAL STRUCTURE NOT BY ASSURA WDWS. MUST SUSTAIN LOADS IMPOSED BY GLAZING SYSTEM AND TRANSFER THEM TO THE BUILDING STRUCTURE.

TYPICAL ANCHORS: SEE ELEV. FOR SPACING
1/4" DIA. ULTRACON BY 'ELCO' (Fu=177 KSI, Fy=155 KSI)
 INTO 2BY WOOD BUCKS OR WOOD STRUCTURES
 1-1/2" MIN. PENETRATION INTO WOOD (HEAD/JAMBS)
 THRU 1BY BUCKS INTO CONC. OR BLOCKS
 1-1/4" MIN. EMBED INTO CONCRETE (HEAD/JAMBS)
 1-1/4" MIN. EMBED INTO BLOCKS (JAMBS)
 DIRECTLY INTO CONCRETE OR BLOCKS
 1-1/4" MIN. EMBED INTO CONCRETE (HEAD/JAMBS)
 1-1/4" MIN. EMBED INTO BLOCKS (JAMBS)

#14 SMS OR SELF DRILLING SCREWS (GRADE 2 CRS)
 INTO METAL STRUCTURES (HEAD/JAMBS)
 (3) THREADS MIN. PENETRATION BEYOND SUBSTRATE
 ALUMINUM: 1/8" THK. MIN. (6063-T5 MIN.)
 STEEL: 1/8" THK. MIN. (Fy = 36 KSI MIN.)
 (STEEL IN CONTACT WITH ALUMINUM TO BE PLATED OR PAINTED)

#12 SMS OR SELF DRILLING SCREWS (GRADE 2 CRS)
 INTO F.B.C. APPROVED MULLIONS
 (3) THREADS MIN. PENETRATION BEYOND SUBSTRATE
 ALUMINUM: 1/8" THK. MIN. (6063-T5 MIN.)
 STEEL: 1/8" THK. MIN. (Fy = 36 KSI MIN.)
 (STEEL IN CONTACT WITH ALUMINUM TO BE PLATED OR PAINTED)

TYPICAL EDGE DISTANCE
 INTO CONCRETE AND MASONRY = 2-1/2" MIN.
 INTO WOOD STRUCTURE = 1" MIN.
 INTO METAL STRUCTURE = 3/4" MIN.

WOOD AT HEAD, SILL OR JAMBS SG = 0.55 MIN.
 CONCRETE AT HEAD, SILL OR JAMBS f'c = 3000 PSI MIN.
 C-90 HOLLOW/FILLED BLOCK AT JAMBS f'm = 2000 PSI MIN.

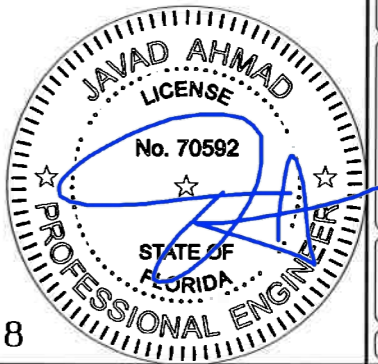

FL #21898

af c
AL-FAROOQ CORPORATION
 ENGINEERS & PRODUCT DEVELOPMENT
 9360 SUNSET DRIVE, SUITE 220
 MIAMI, FLORIDA 33173 (C.A.N. 3538)
 TEL (305) 264-8100 FAX (305) 262-6978
 COMP-ANL\W17-20AW

SERIES 525 ALUMINUM CASEMENT WDW. (L.M.I.)
Assura Windows & Doors, LLC.
 1543 N. Powerline Road
 Pompano Beach, FL 33069
 Tel. (305) 887-2646 Fax. (-)

revisions:	no	date	description

date: 02-10-17
 scale: 1/2" = 1"
 dr. by: TARIQ
 chk. by:

drawing no.
W17-20
 sheet 2 of 5

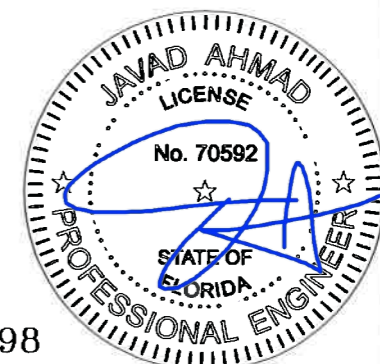
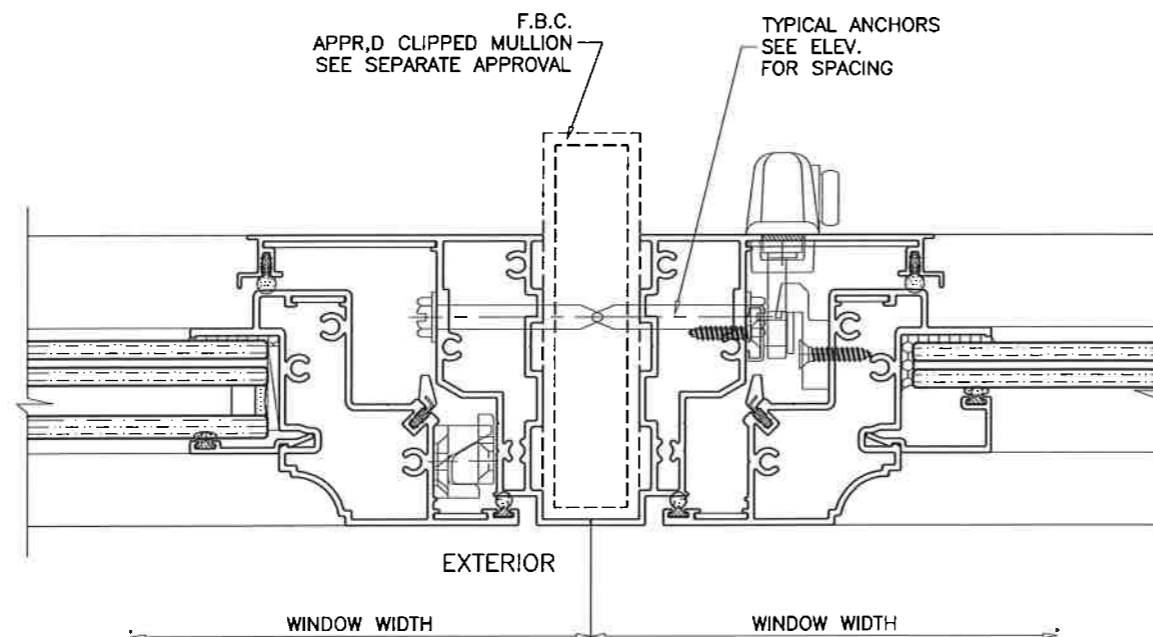
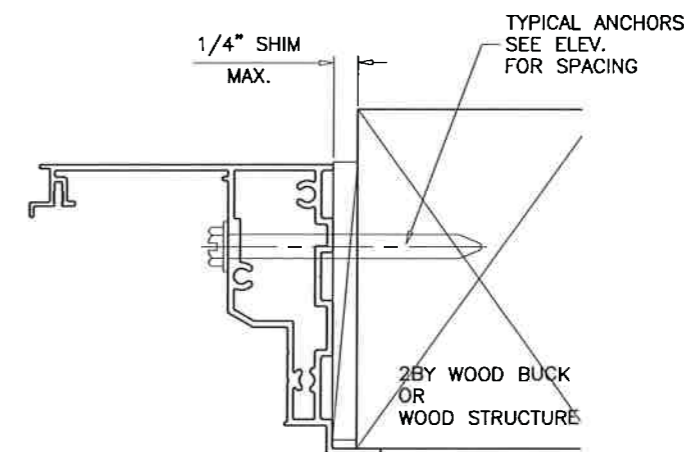
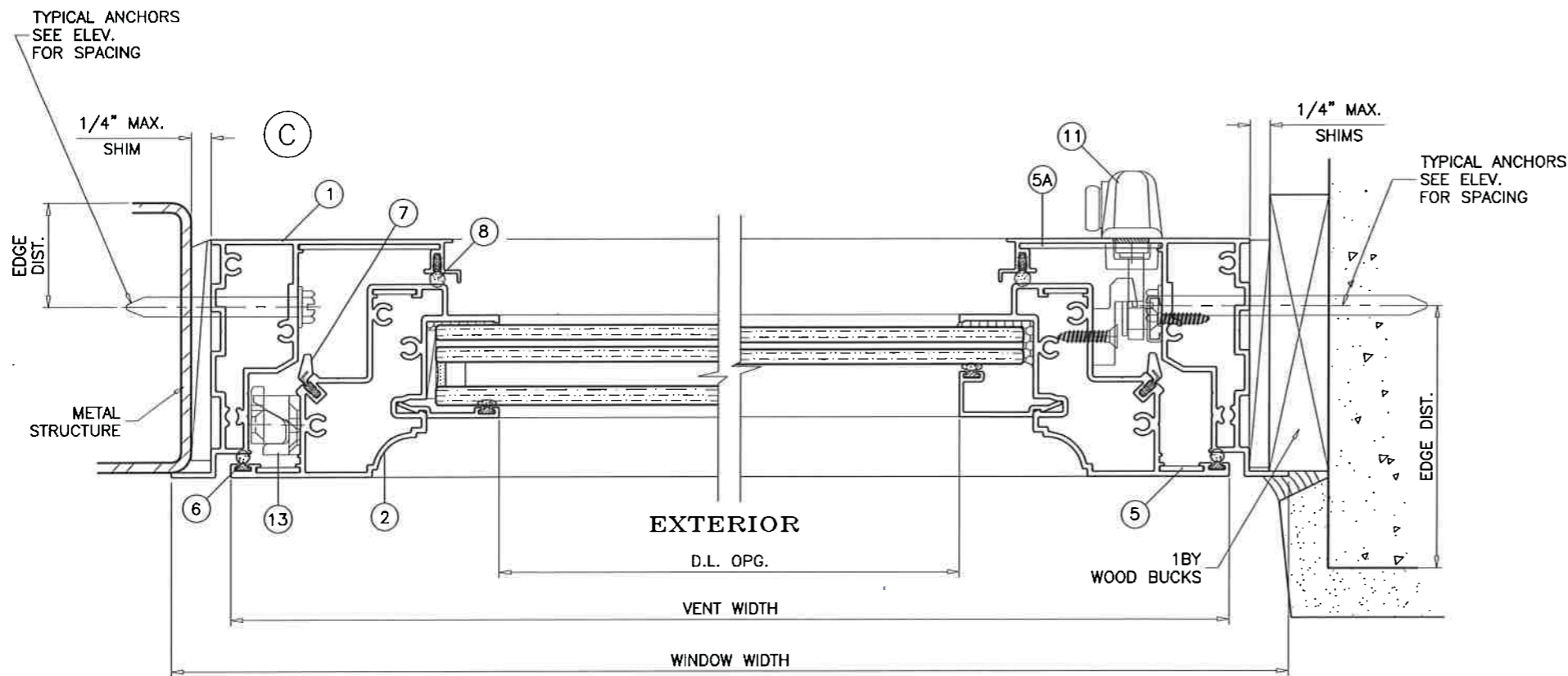

FL #21898

Sealed: 10/13/2017

afc

AL-FAROOQ CORPORATION
 ENGINEERS & PRODUCT DEVELOPMENT
 9360 SUNSET DRIVE, SUITE 220
 MIAMI, FLORIDA 33173 (C.A.N. 3538)
 TEL. (305) 264-8100 FAX. (305) 262-6978

SERIES 525 ALUMINUM CASEMENT WDW. (L.M.I.)
Assura Windows & Doors, LLC.
 1543 N. Powerline Road
 Pompano Beach, Fl. 33069
 Tel. (305) 887-2646 Fax. (-)

revisions:	
no	date by description

date: 02-10-17	scale: 1/2" = 1"
dr. by: TARIQ	chk. by:
drawing no. W17-20	sheet 3 of 5

COMP-ANL\W17-20AW

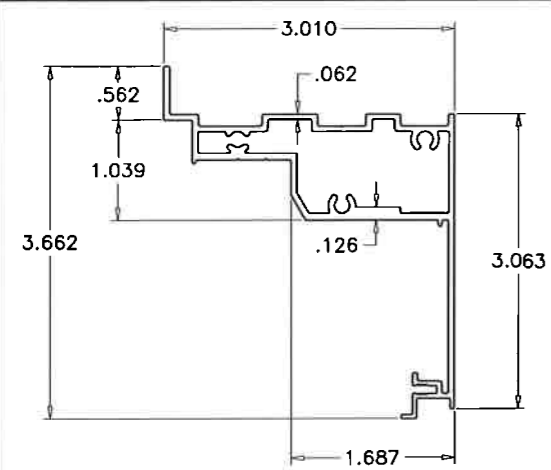

① FRAME

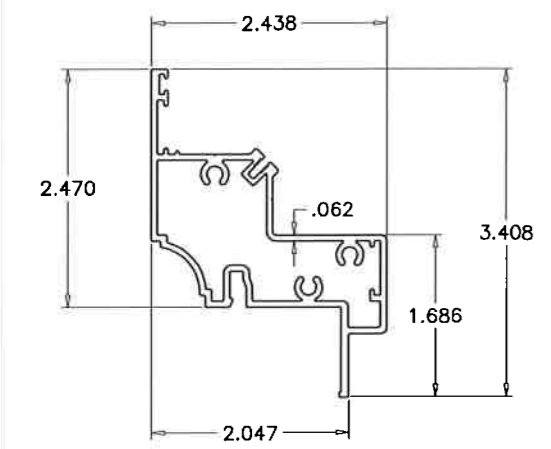

② VENT

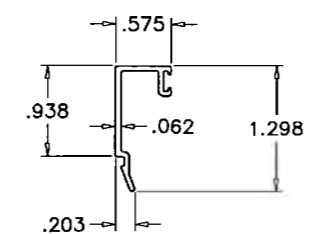

③ GLAZING BEAD (LAM. GLASS)

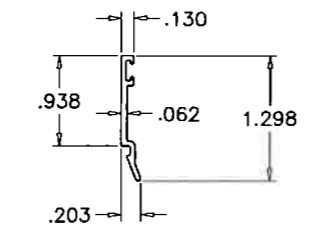

③A GLAZING BEAD (INSUL. LAM. GLASS)

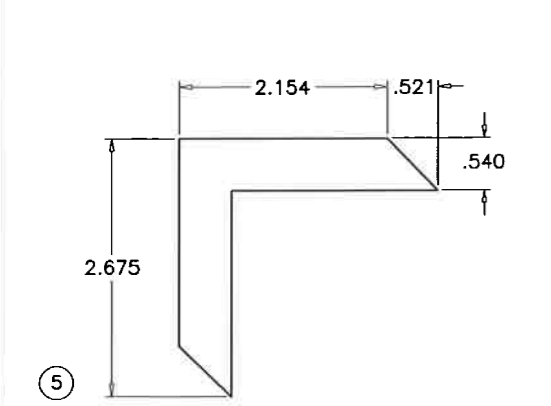

⑤

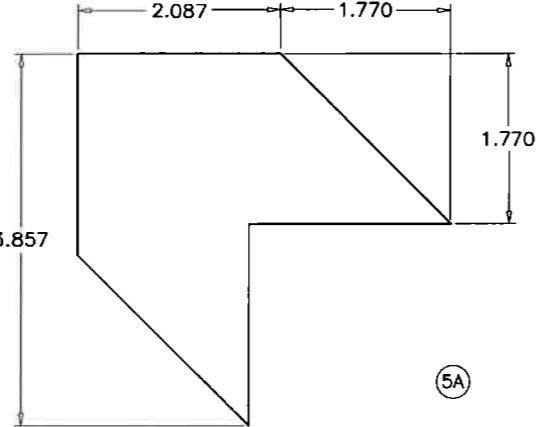

⑤A

CORNER KEYS

SCALE 1:1

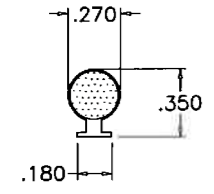

⑥

VENT EXTERIOR W'STRIPPING
GLAZING SPACER (LAM. GLASS)

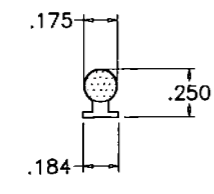

⑥A

GLAZING SPACER (INSUL. LAM. GLASS)

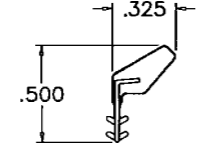

⑦

VENT INTERIOR W'STRIPPING

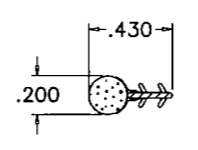

⑧

FRAME W'STRIPPING

ITEM	PART #	QUANTITY	DESCRIPTION	MATERIAL	MANF./SUPPLIER/REMARKS
1	TM-358	4	WINDOW FRAME	6063-T6	-
2	TM-359	4	WINDOW VENT	6063-T6	-
3	TM-327	4	GLAZING BEAD (LAM. GLASS)	6063-T6	-
3A	TM-326	4	GLAZING BEAD (INSUL. LAM. GLASS)	6063-T6	-
4	#10 X 1"	2/ CORNER	ASSEMBLY FASTENERS	CRS	PH SMS
5	-	1/ CORNER	CORNER KEY, .060" THK.	ALUMINUM	-
5A	-	1/ CORNER	CORNER KEY, .060" THK.	ALUMINUM	-
6	32001	AS REQD.	GLAZING SPACER (FOAM FILLED BULB) (LAM. GLASS)	TPE POLYPROPYLENE	DUROMETER 70±5 SHORE A
6A	32011	AS REQD.	GLAZING SPACER (FOAM FILLED BULB) (INSUL. LAM. GLASS)	TPE POLYPROPYLENE	DUROMETER 70±5 SHORE A
7	QEZD 250	AS REQD.	VENT INTERIOR W'STRIPPING	-	AMESBURY
8	12298	AS REQD.	FRAME W'STRIPPING	-	AMESBURY
9	-	2/ LITE	SETTING BLOCK, AT 1/4 POINTS	EPDM	DUROMETER 85±5 SHORE A
10	OP10603G	1	DUAL ARM OPERATOR	-	RADISSON IND.
11	PO-2301	1	MULTIPOINT LOCKING HANDLE	-	RADISSON IND.
12	316	2	3000 SERIES 4-BAR PROJECTION HINGES	-	ADVANTAGE MANUF. CORP.
13	1549-3	-	SNUBBER	-	ADVANTAGE MANUF. CORP.

SEALANT:

ALL JOINTS AND FRAME CONNECTIONS SEALED WITH CRL SMALL JOINT SEAM SEALER.

HINGES:

SERIES 3000 MAGNUM 4 BAR OFFSET HINGES BY 'ADVANTAGE MANUF. CORP.' LOCATED AT TOP AND BOTTOM CORNERS FASTENED TO FRAME WITH (3) #10 X 3/8" PH SMS FASTENED TO VENT WITH (5) #10 X 1/2" PH SMS

LOCKS:

7 POINT LOCK SYSTEM BY 'RADISSON IND.' AT FRAME JAMB LOCK OPERATOR AT 6-3/4" FROM SILL HANDLE SECURED TO FRAME WITH (2) #10 X 1/2" PH MS LOCK BAR SECURED TO FRAME WITH (9) UNIFORMLY SPACED LOCK GUIDES, EACH ATTACHED WITH (2) #8 X 3/4" FH TEKS

STRIKERS FACING LOCKING POINTS ATTACHED TO VENT WITH (5) #10 X 1/2" FH SCREWS

OPERATOR:

DUAL ARM OPERATOR OP10603G BY 'RADISSON IND.' LOCATED AT SILL END SECURED TO FRAME SILL WITH (2) #10 X 5/8" FH SMS OPERATOR ARM SECURED TO VENT WITH (3) #8 X 3/4" FH SMS PIVOT ARM SECURED TO VENT WITH (3) #8 X 3/4" FH SMS

SNUBBERS:

SERIES 6000 ALUMINUM SNUBBERS BY 'ADVANTAGE MANUF. CORP.' AT 6" FROM ENDS AND 39" O.C. (3) DRIVERS AT VENT EACH SECURED WITH (3) #10 X 5/8" FH SMS (3) RECIEVERS AT FRAME EACH SECURED WITH (2) #10 X 5/8" FH SMS

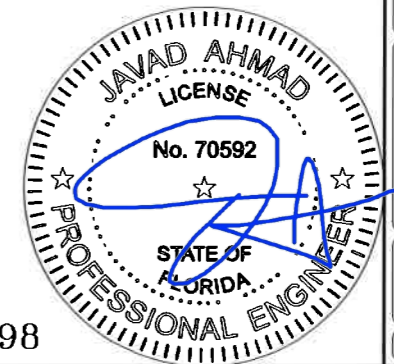

FL #21898

Sealed: 10/13/2017

af c
AL-FAROOQ CORPORATION
 ENGINEERS & PRODUCT DEVELOPMENT
 9360 SUNSET DRIVE, SUITE 220 (C.A.N. 3538)
 MIAMI, FLORIDA 33173 FAX. (305) 262-6978
 TEL. (305) 264-8100

SERIES 525 ALUMINUM CASEMENT WDW. (L.M.I.)
Assura Windows & Doors, LLC.
 1543 N. Powerline Road
 Pompano Beach, FL. 33069
 Tel. (305) 887-2646 Fax. (-)

revisions:	no	date	by	description
date	02-10-17	scale:	1/2" = 1"	
dr. by:	TARIQ	chk. by:		
drawing no.	W17-20			
sheet	4 of 5			

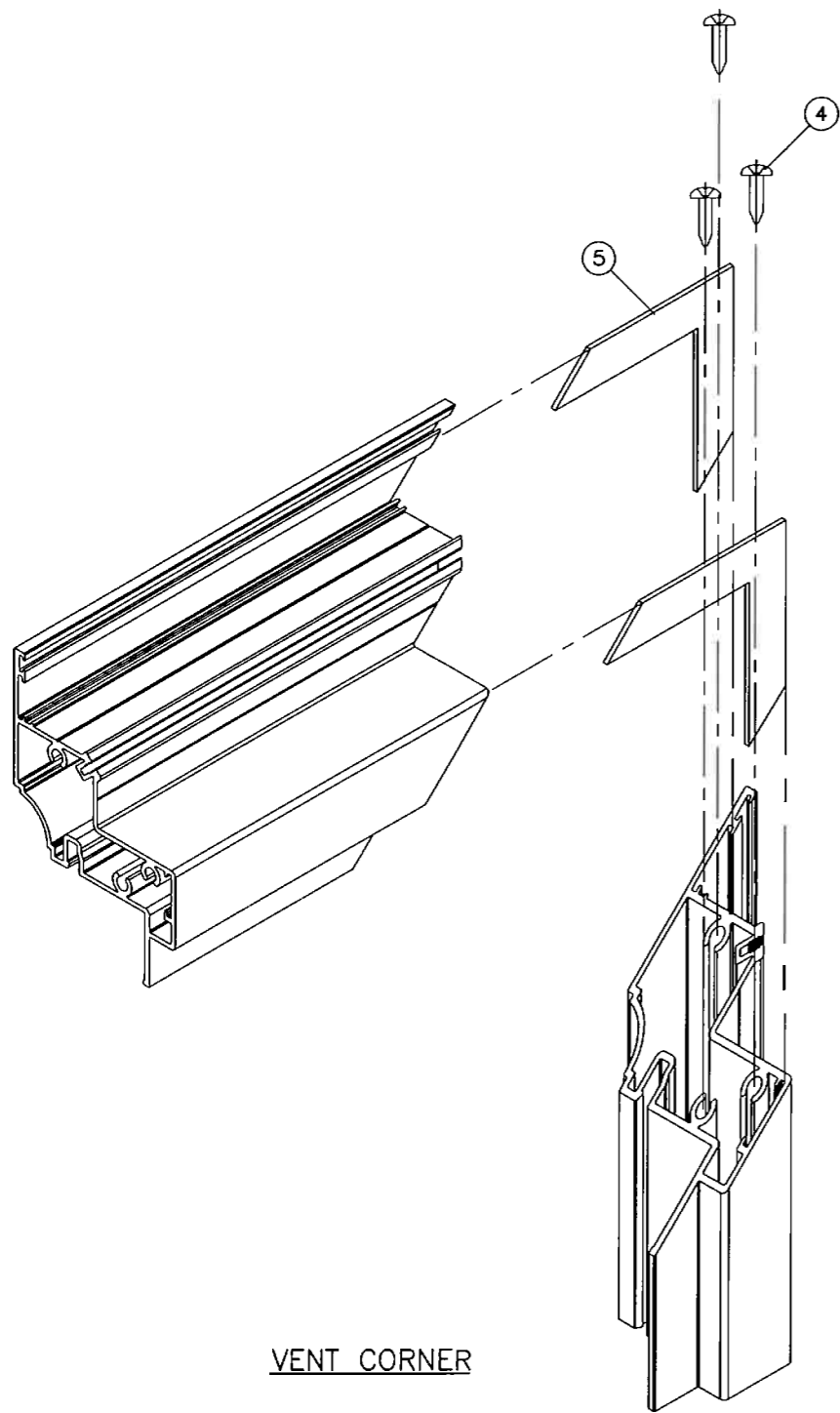

VENT CORNER

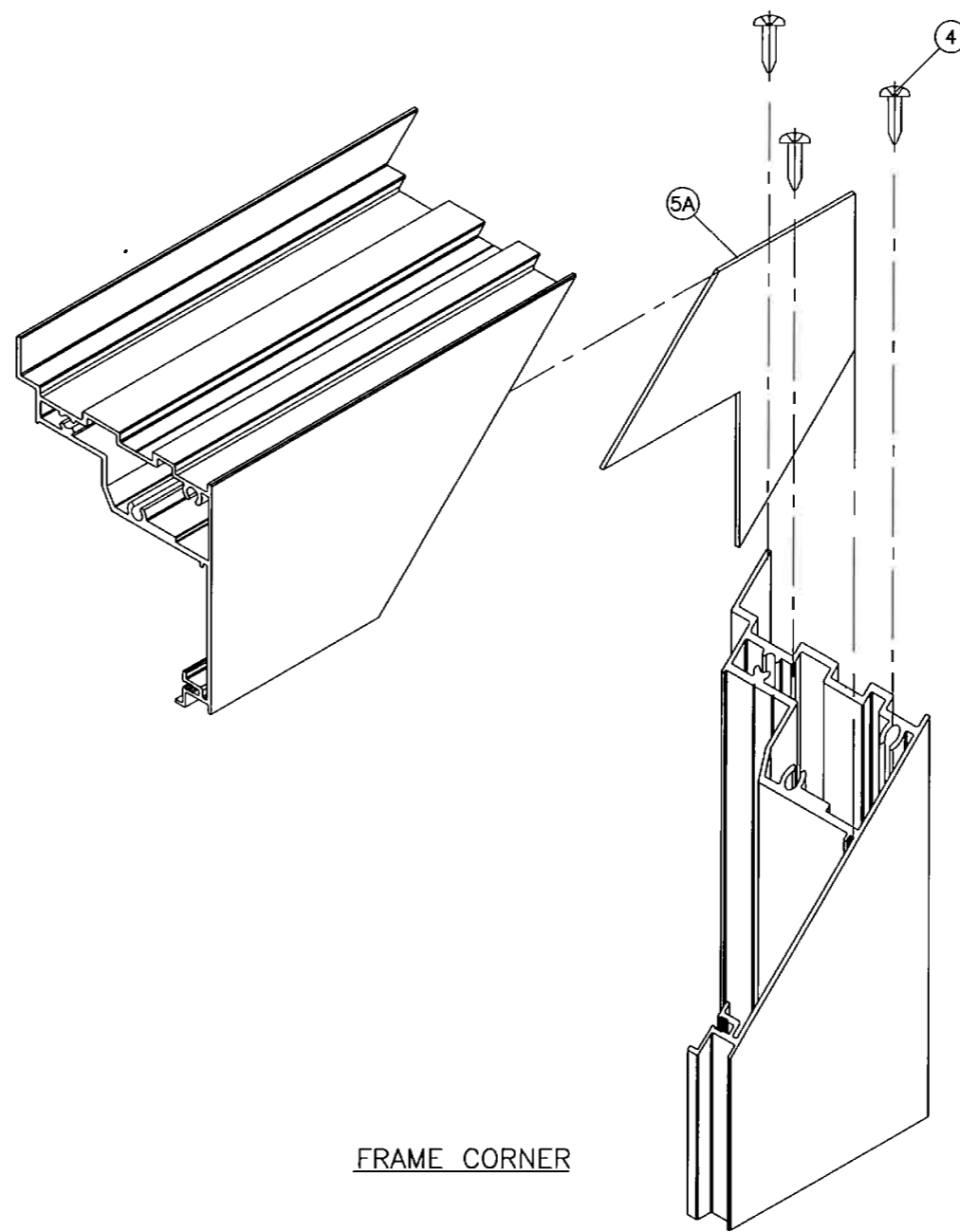

FRAME CORNER

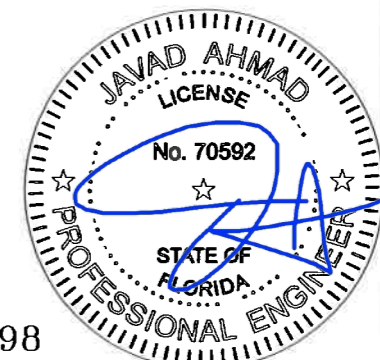

FL #21898

a f c

AL-FAROOQ CORPORATION
 ENGINEERS & PRODUCT DEVELOPMENT
 9360 SUNSET DRIVE, SUITE 220
 MIAMI, FLORIDA 33173 (C.A.N. 3538)
 TEL. (305) 264-8100 FAX. (305) 262-6978

COMP-ANL\W17-20AW

SERIES 525 ALUMINUM CASEMENT WDW. (L.M.I.)

Assura Windows & Doors, LLC.
 1543 N. Powerline Road
 Pompano Beach, Fl. 33069
 Tel. (305) 887-2646 Fax. (-)

revisions:	no	date	by	description
date:	02-10-17			
scale:	1/2" = 1"			
dr. by:	TARIQ			
chk. by:				
drawing no.	W17-20			
sheet	5 of 5			