

Modular Semi-Auto Filler

Imagined

Develop a modular, semi-automated, net weigh fill platform to satisfy a broad spectrum of applications with minimal changeover, while protecting the investment towards a fully automated system.

Engineered Solution

A single station filler expandable to multi heads, with interchangeable scale platforms sized for various container profiles and weights. Expandable platform to accommodate customers growing needs into full automation.

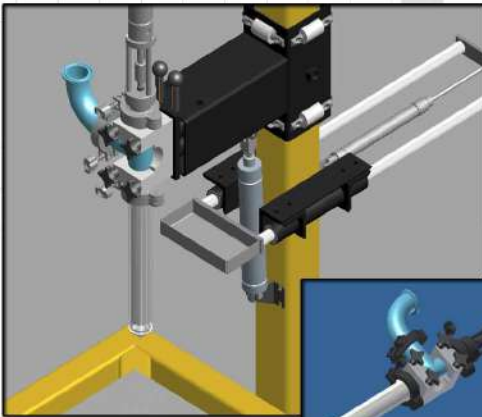

Subsurface Filler

Primarily used for filling 'foamy' products. Nozzle remains submerged throughout the cycle to minimize the potential for air entrapment during filling.

Drip pan is included to prevent product drippings from landing on the container.



Consideration must be given to incorporating a VFD for pump control to prevent product from splashing at the start of the fill cycle and to eliminate dead heading the pump between cycles.

Plug Valve Filler

Ideal for thixotropic products that may require a blow off for a cleaner cutoff.

Valves are available in a range of sizes and are interchangeable through a common interface.

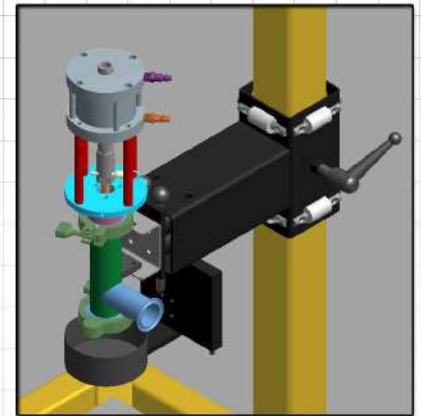

Ball Valve Filler

Suitable for applications requiring dedicated valves as a means for preventing cross contamination.

Filler style optionally available with either interchangeable individual ball valves, or ball valves and actuator assemblies.

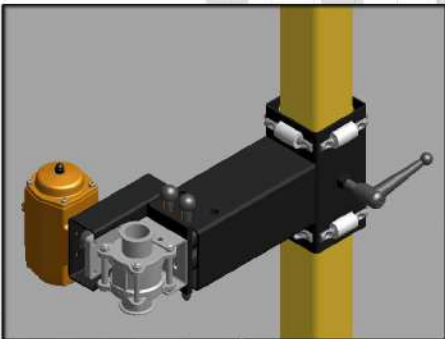

Ball valves are available in a range of sizes and feature sanitary connections, and stainless steel construction with Teflon filled cavities.

Quick and tool-less changeover.

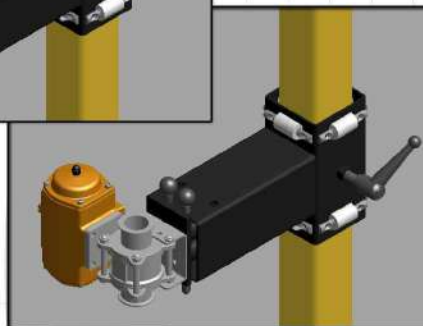

Scale Option

System can be equipped with multiple scales including a 12" or 24" bench scale, or a custom lifter scale for raising the container off of a conveyor surface during the weighing portion of the fill cycle.

Scales are interchangeable and are

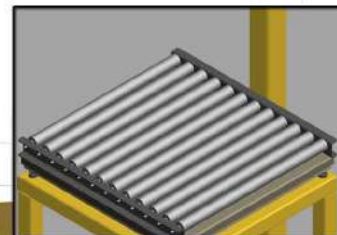

calibrated by the touch of a button on the HMI.

Automated Filler

All systems can be expanded to a fully automated unit when equipped with a tabletop conveyor and indexing stop cylinders.

Preserves customer investment as this can be added at a future date.

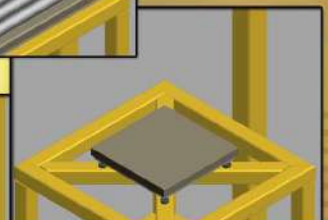
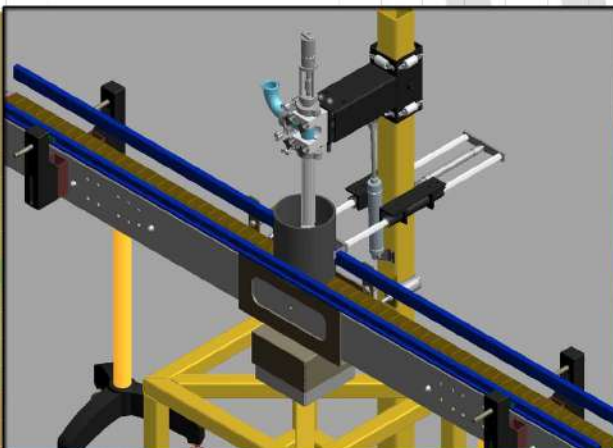

Available with integrated conveyor surface.

Build your own custom filler . . .

- **STEP 1: Select filler style**
 - Subsurface Fill
 - Ball Valve/Actuator
 - Ball Valve
 - Plug Valve
- **STEP 2: Select respective valve size and quantity**
- **STEP 3: Select scale type and size**
- **STEP 4: Select desired options**

. . . It's that easy!

● Subsurface Fill System with Drip Pan

Valve Sizes: ● 2" ● 1-1/2" ● 1" ● 5/8"

● Replaceable Ball Valve/Actuator System

Valve Sizes: ● 2" ● 1-1/2" ● 1" ● 1/2"

● Replaceable Valve System

Valve Sizes: ● 2" ● 1-1/2" ● 1" ● 1/2"

● Plug Valve System

Valve Sizes: ● 2" ● 1-1/2" ● 1"

● Scale Type:

● 12" Bench Scale ● 24" Bench Scale ● Lifter Scale

● Options:

- Pivot Drip Tray Adder*
- 12" Conveyor Adder
- 24" Conveyor Adder
- Container Alignment Jig
- Pump VFD (230VAC 1-Phase IN, 230VAC 3-Phase OUT, 1HP)**

* Not applicable for 'Subsurface Fill System.

** Other ratings available upon request.

When having difficulties in your assembly or manufacturing process, contact Kinesys Automation for more information about a field proven solution.



Kinesys Automation, Inc.

5 Fir Court, Unit 3

Oakland, New Jersey 07436

Phone: (201) 337-5000 Fax: (201) 337-5200

sales@KinesysAutomation.com

www.KinesysAutomation.com