

Neighborhood 1 7000 Schedule

Zoning/Use Residential-Farm  
 Topography Level  
 Utilities Drilled WellSeptic System  
 Street Paved

Reference 1  
 Reference 2  
 Tran/Land/Bldg 3 1 9  
 FLOOD MAP & 0 SHORELAND ZONE 0  
 Exemption(s) 9 0 0 Land Schedule 1

**Land Description**

Units	Method - Description	Price/Unit	Total	Fctr	Influence	Value
1.00	Acres-Homesite	8,400.00	8,400	100%		8,400
0.18	Acres-Secondary 1	1,500.00	270	100%		270
1.00	# -Lot Improvements	7,500.00	7,500	100%		7,500
Total Acres 1.18			Land Total			16,170

**Outbuildings/Additions/Improvements**

Description	Year	Units	Grade	RCN	Cond	Percent Good			Value Rcnld
						Phy	Func	Econ	
Marlette M/H	1985	14X70	A 100	32,501	Ava.	40%	100%	100%	13,000
Concrete slab	1987	980	C 100	3,104	Ava.	81%	100%	100%	2,514
One Story Frame	1990	480	C 100	25,890	Ava.	82%	75%	100%	15,922
Concrete slab	1990	480	C 100	1,520	Ava.	82%	100%	100%	1,246
Fin Garage	1988	1120	C 100	21,695	Ava.	81%	100%	100%	17,573
Concrete slab	1988	1120	C 100	3,548	Ava.	81%	100%	100%	2,874
Wood Deck	1990	60	C 100	326	Ava.	82%	100%	100%	267
Wood Deck	1985	140	C 100	760	Ava+	84%	100%	100%	638
Frame Shed	1985	96	D 100	1,229	Ava-	63%	75%	100%	580
Frame Shed	1985	216	C 100	3,128	Ava.	80%	100%	100%	2,502
1,460 SFLA		Field1				Outbuilding Total			57,116
<b>Acpt Land</b>		16,200	<b>Accepted Bldg</b>		57,100	<b>Total</b>			73,300

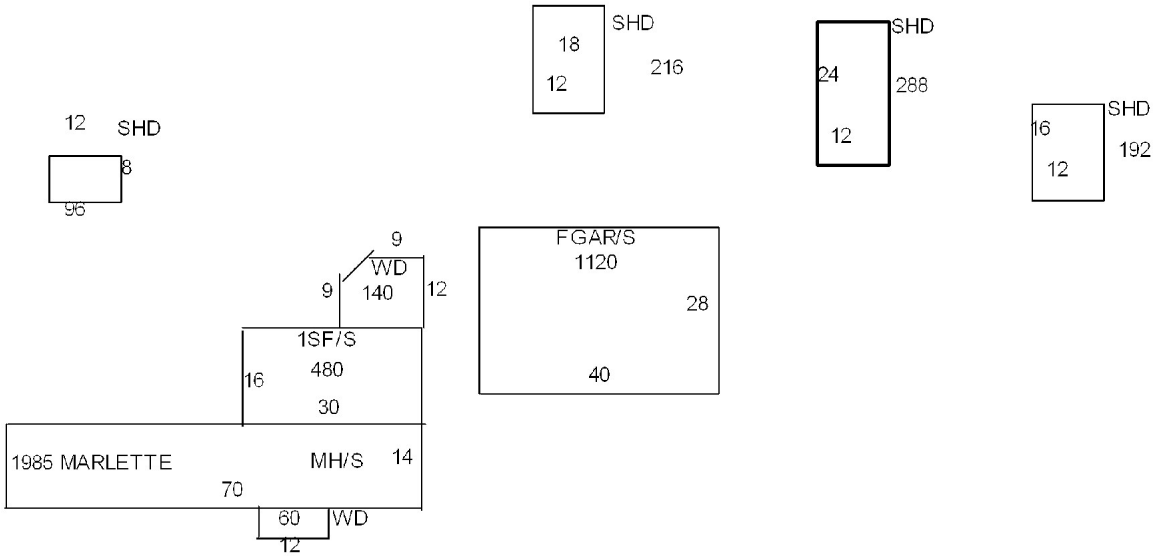

Mapleton  
 Name: MOSHER, FRANCINE L. BUCK

**Valuation Report**

08/01/2019

Page 3

Map/Lot:

009-003-002

Account: 2332 Card: 2 of 2

Location:

1716 CHAPMAN RD

Neighborhood 1 7000 Schedule

Zoning/Use Residential-Farm  
 Topography Level  
 Utilities Drilled WellSeptic System  
 Street Paved

Reference 1  
 Reference 2  
 Tran/Land/Bldg 3 0 0  
 FLOOD MAP & 0 SHORELAND ZONE 0  
 Exemption(s) 9 0 0 Land Schedule 1

<b>Outbuildings/Additions/Improvements</b>							Percent Good			Value
Description	Year	Units	Grade	RCN	Cond	Phy	Func	Econ	Rcnld	
Frame Shed	2012	288	C 100	4,170	Avq.	92%	90%	100%	3,452	
Frame Shed	2013	192	C 100	2,780	Avq.	92%	100%	100%	2,558	
1,460 SFLA		Field1								
						<b>Outbuilding Total</b>			<b>6,010</b>	
<b>Acpt Land</b>			0	<b>Accepted Bldg</b>			6,000	<b>Total</b>		6,000

Mapleton  
Name: MOSHER, FRANCINE L. BUCK

**Valuation Report**

08/01/2019

Page 4

Map/Lot:

009-003-002

Account: 2332

Location:

1716 CHAPMAN RD

---

<b>Card</b>	<b>Land</b>	<b>Calculated Building</b>	<b>Calc. Total</b>	<b>Land</b>	<b>Correlated Building</b>	<b>Total</b>
1	16,200	57,100	73,300	16,200	57,100	73,300
2	0	6,000	6,000	0	6,000	6,000
<b>TOTAL</b>	16,200	63,100	79,300	16,200	63,100	79,300

---