

Sulfur-Modified Zero-Valent Iron for Remediation Applications at DOE Sites – 13600

Thomas W. Fogwell, Ph.D., P.E.*, Pete Santana**

*Fogwell Consulting; P.O. Box 20221, Piedmont, CA 94620; TWF01@sbcglobal.net

** SMI-PS, Inc.; 2073 Prado Vista, Lincoln, CA 95648; Pete@smiwater.com

ABSTRACT

Many DOE remediation sites have chemicals of concern that are compounds in higher oxidation states, which make them both more mobile and more toxic. The chemical reduction of these compounds both prevents the migration of these chemicals and in some cases reduces the toxicity. It has also been shown that zero-valent iron is a very effective substance to use in reducing oxygenated compounds in various treatment processes. These have included the treatment of halogenated hydrocarbons in the form volatile organic compounds used as solvents and pesticides. Zero-valent iron has also been used to reduce various oxidized metals such as chromium, arsenic, and mercury in order to immobilize them, decrease their toxicity, and prevent further transport. In addition, it has been used to immobilize or break down other non-metallic species such as selenium compounds and nitrates. Of particular interest at several DOE remediation sites is the fact that zero-valent iron is very effective in immobilizing several radioactive metals which are mobile in their oxidized states. These include both technetium and uranium.

The main difficulty in using zero-valent iron has been its tendency to become inactive after relatively short periods of time. While it is advantageous to have the zero-valent iron particles as porous as possible in order to provide maximum surface area for reactions to take place, these pores can become clogged when the iron is oxidized. This is due to the fact that ferric oxide has a greater volume for a given mass than metallic iron. When the surfaces of the iron particles oxidize to ferric oxide, the pores become narrower and will eventually shut. In order to minimize the degradation of the chemical activity of the iron due to this process, a modification of zero-valent iron has been developed which prevents or slows this process, which decreases its effectiveness. It is called sulfur-modified iron, and it has been produced in high purity for applications in municipal water treatment applications.

Sulfur-modified iron has been found to not only be an extremely economical treatment technology for municipal water supplies, where very large quantities of water must be treated economically, but it has also been demonstrated to immobilize technetium. It has the added benefit of eliminating several other harmful chemicals in water supplies. These include arsenic and selenium. In one large-scale evaluation study an integrated system implemented chemical reduction of nitrate with sulfur-modified iron followed by filtration for arsenic removal. The sulfur-modified iron that was used was an iron-based granular medium that has been commercially developed for the removal of nitrate, co-contaminants including uranium, vanadium and chromium, and other compounds from water. The independent study concluded that "It is foreseen that the greatest benefit of this technology (sulfur-modified iron) is that it does not produce a costly brine stream as do the currently accepted nitrate removal technologies

of ion exchange and reverse osmosis. This investigation confirmed that nitrate reduction via sulfur-modified iron is independent of the hydraulic loading rate. Future sulfur-modified iron treatment systems can be designed without restriction of the reactor vessel dimensions. Future vessels can be adapted to existing site constraints without being limited to height-to-width ratios that would exist if nitrate reduction were to depend on hydraulic loading rate."

Sulfur-modified iron was studied by the Pacific Northwest National Laboratory (PNNL) for its effectiveness in the reduction and permanent sequestration of technetium. The testing was done using Hanford Site groundwater together with sediment. The report stated, "Under reducing conditions, TcO_4 is readily reduced to TcIV, which forms highly insoluble oxides such as $TcO_2 \cdot nH_2O$. However, (re)oxidation of TcIV oxides can lead to remobilization. Under sulfidogenic conditions, most TcIV will be reduced and immobilized as Tc_2S_7 , which is less readily remobilized, even under oxic conditions. This process should be favored by stimulation of sulfidogenic conditions." The sulfur-modified iron provides the sulfur, together with the iron, to maintain this stable sequestration of technetium. As a result of these and other studies demonstrating the cost-effectiveness of sulfur-modified iron in treating technetium and other hazardous compounds in Hanford Site groundwater and its cost-effectiveness in reducing nitrate, the Richland Operations Office of the Department of Energy issued a change order to the Central Plateau Contractor providing for the testing of sulfur-modified iron in a mobile pilot unit at the Hanford Site. Further testing is anticipated to produce refinements in operating conditions and further optimization of the existing process.

INTRODUCTION

Many DOE remediation sites have concentrated liquid wastes that contain oxidized compounds that need to be treated in order to render them suitable for final sequestration. Many also have oxidized compounds in the groundwater, both radioactive and chemically toxic, that need to be treated and concentrated in order for them to be disposed in a safe manner. Sulfur-modified zero-valent iron has the potential of being a very economical solution to these treatment needs.

COCs AT DOE SITES

Many of DOE's major sites have extremely large quantities of waste that needs to be disposed of in a safe manner. The following table gives a summary of the quantities at the Hanford Site, as a prime example [1].

Table I. Hanford Waste Summary for 2011

Activity	Waste Type	Amount
Solid waste generated during onsite cleanup activities	Solid mixed waste	522 tons (474,000 kilograms)
	Radioactive waste	4022 tons (3,649,000 kilograms)
Solid waste received at the Hanford Site from offsite (includes Hanford Site generated waste treated by an offsite contractor and returned to the site as newly generated waste)	Solid mixed waste	195 tons (177,000 kilograms)
	Radioactive waste	185 tons (168,000 kilograms)
Dangerous waste shipped off the Hanford Site	See Table 5.4	242 tons (219,000 kilograms)
Waste volume pumped from underground single-shell waste storage tanks to double-shell waste storage tanks (Includes flush/dilution water)	Liquid waste	560,000 gallons (2,120,000 liters)
Waste volume in underground single-shell waste storage tanks at the end of 2011	Liquid waste	29.5 million gallons (112 million liters)
Waste added to underground double-shell waste storage tanks	Liquid waste	1,560,000 liters (412,000 gallons)
Waste volume in underground double-shell waste storage tanks at the end of 2011	Liquid waste	26 million gallons (98 million liters)
Waste dispositioned and shipped offsite from the Waste Receiving and Processing Facility	Solid waste	50 cubic yards (713 cubic meters)
Waste disposed of in Trenches 31 and 34	Mixed low-level solid waste	62,960 cubic feet (1,783 cubic meters)
Waste disposed of at the Environmental Restoration Disposal Facility	Solid waste	1,500,200 tons 1,360,895 metric tons)
Aqueous waste volume received at the Liquid Effluent Retention Facility	Wastewater containing low levels of organic compounds and tritium	16.8 million gallons (63.6 million liters)
Volume of waste water treated and disposed at the 200 Area Effluent Treatment Facility	Wastewater containing toxic metals, radionuclides, ammonia, and organic compounds	19.9 million gallons (75.3 million liters)
Wastewater volume treated (evaporated) at the 242-A Evaporator	Liquid waste from single-shell tanks	0 gallons (0 liters)
Effluent volume disposed of at the 200 Area Treated Effluent Disposal Facility	Uncontaminated, treated liquid waste	14.2 million gallons (53.8 million liters)

It can be seen from the table above that much of the waste is in liquid or mixed form, which makes it suitable for processing by zero-valent iron.

For groundwater seeps at the Hanford Site along the Columbia the following Table II gives the concentrations in the various 100 Areas [1].

Table II. Columbia River Riverbank Seeps Concentration Ranges for Selected Chemicals in Water

Monitoring Samples, Hanford Site (2006 through 2011)
Ambient-Water
Quality Criterion

	Level ^(a)	100-BC Area	100-K Area	100-N Area	100-D Area	100-H Area
Dissolved Metals (µg/L)						
Number of Samples		2	2	2	2	2
Antimony ^(b)	NA	3.5	3.5	3.5	3.5	3.5
Arsenic	190	5 ^(b)	6.2 - 7.1	6.5 - 7.6	7.2 - 7.4	5.0 - 5.5
Cadmium ^(b)	0.59	1.0	1.0	1.0	1.0	1.0
Chromium	10	4.9 - 24.2	31.4 - 31.9	1 - 3.5	22.4 - 23.2	5.7 - 5.8
Copper	6.0	3.0 - 7.7	3.0 - 3.84	3.0 - 3.8	3.0 ^(b)	3.0 ^(b)
Lead	1.1	3.3 - 3.6	3.3 ^(h)	3.3 ^(h)	3.3 ^(h)	3.3 ^(h)
Nickel	83	1.5 - 7.9	1.5 ^(b)	1.5 - 2.5	1.5 - 1.8	1.5 ^(b)
Silver ^(b)	0.94 ^(c)	1.0	1.0	1.0	1.0	1.0
Thallium ^(b)	NA	5.0	5.0	5.0	5.0	5.0
Zinc	55	6.6 - 35.1	3.3 - 6.8	3.3 - 20.4	3.3 - 10.7	3.3 ^(b)
Total Recoverable Metals (µg/L)						
Number of Samples		2	2	2	2	2
Chromium	96	4.9 - 24.2	31.4 - 31.9	1.0 - 3.5	22.4 - 23.2	5.7 - 5.8
Mercury ^(b)	0.012	0.066	0.066	0.066	0.066	0.066
Selenium	5.0	6.0 ^(h)	6.0 ^(h)	6.0 ^(h)	6.0 - 6.51	6.0 ^(h)
Anions (mg/L)						
Number of Samples		1	2	1	1	1
Nitrate ^(d)	10	3.3	3.3 - 10.5	2.4	13.8	3.8

(a) Ambient water quality criteria values (WAC 173 201A 240) for chronic toxicity unless otherwise noted.

(b) Not detected at laboratory reporting limit.

(c) Value for acute toxicity; chronic value not available.

(d) Nitrate as NO₃⁻ ion. Drinking water standard (WAC 246-290).

NA = Not available.

Several of these, notably chromium, mercury, selenium and nitrate, are found at levels that are above the Ambient Water-Quality Criterion. Sulfur-modified iron has shown to be effective for the treatment of these chemicals.

The picture for groundwater at the Hanford is particularly dramatic with respect to levels of contamination above the applicable groundwater standards. This is illustrated in the following Figure 1 showing the concentrations as multiples of the applicable groundwater standard at various locations on the Hanford Site [1].

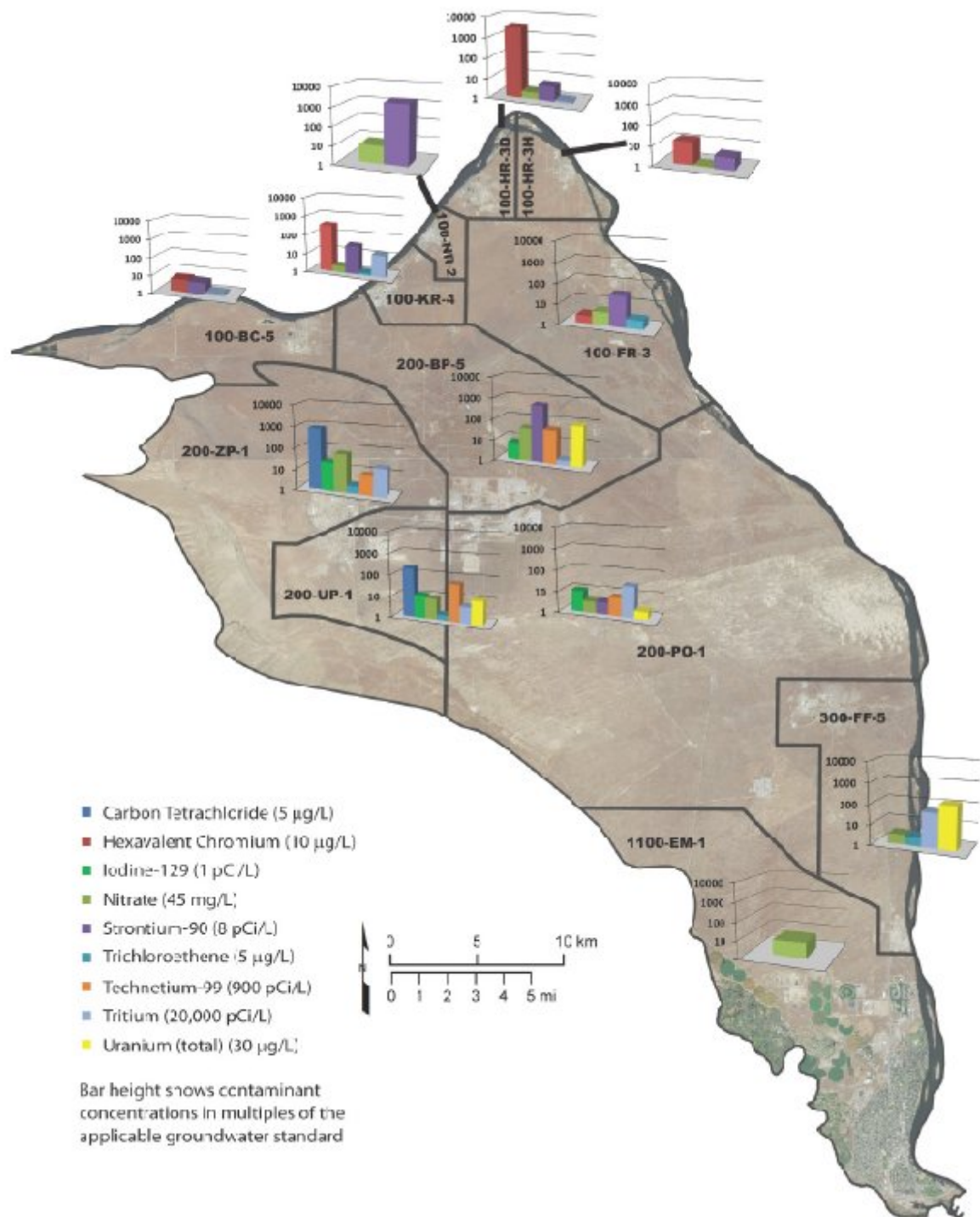

Figure 1. Maximum Concentrations of Groundwater Contaminants in each Groundwater Interest Area (2011)

ZERO-VALENT IRON TREATMENT FOR COCs

In the above list of chemicals of concern for the Hanford Site, carbon tetrachloride stands out as a particularly persistent contaminant on the Central Plateau. In a 2005 article comparing different forms of zero-valent iron for the reduction of carbon tetrachloride the authors found [2], “The distribution of products from reduction of carbon tetrachloride is more favorable with $\text{Fe}^{\text{H}2}$, which produces less chloroform than reaction with Fe^{BH} .” The $\text{Fe}^{\text{H}2}$ is a two-phase material consisting of 40 nm $\alpha\text{-Fe}^0$ (made up of crystals approximately the size of the particles) and Fe_3O_4 particles of similar size or larger containing reduced sulfur.” This indicates that sulfur-containing zero-valent iron has superior treatment properties to other forms of zero-valent iron.

Hexavalent chromium is already being treated in situ by reduction using iron in the In Situ Redox Manipulation (ISRM) zones at the Hanford Site. In a 2012 article the authors state [3], “Permeable reactive barriers (PRB) made of Fe^0 and in situ redox manipulation (ISRM) zones effectively remediate Cr-contaminated aquifers.” They used an isotope ratio method to determine the extent of reduction of the hexavalent chromium (Cr), as indicated in the following Figure 2 from their article.

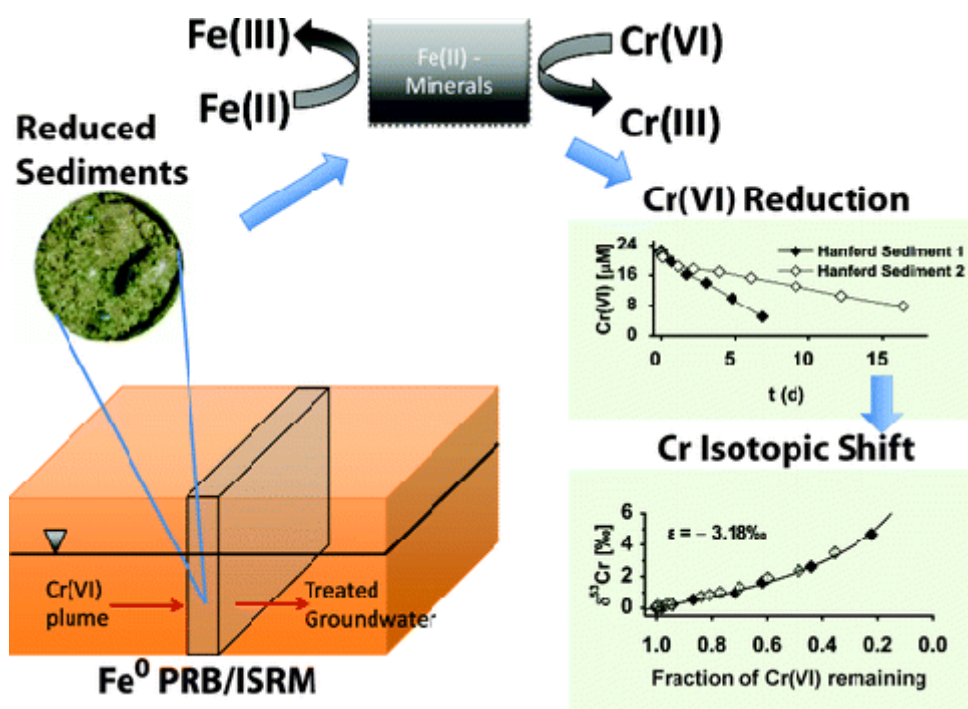

Figure 2. Chromium Isotopic Shift and Cr(VI) Reduction

Even the treatment of iodine by zero-valent iron is a feasible option. It can be sequestered in the reduced form as was shown in the work reported in a 2009 scientific article [4]. The authors state, “This study investigated reductive transformation of iodine by zero-valent iron (ZVI), and the subsequent detoxification of iodine-laden wastewater. ZVI completely reduced aqueous iodine to non-toxic iodide. Respirometric bioassay with real iodine-laden LCD manufacturing

wastewater demonstrated that ZVI was effective for detoxifying iodine and consequently enhancing biodegradability of wastewater. This result suggested that ZVI pretreatment may be a feasible option for the removal of iodine in LCD processing wastewater, instead of more costly processes such as adsorption and chemical oxidation, which are commonly in the iodine-laden LCD wastewater treatment facility.” Their conclusion indicates that not only is zero-valent iron effective, but its use can greatly reduce the cost of treatment.

Sulfur-modified zero-valent iron was originally developed to treat nitrate contaminated groundwater. As such, the very large quantities of nitrated groundwater at the Hanford Site would make a particularly attractive application of sulfur-modified zero-valent iron. A large-scale study was performed by the City of Rippon for determining the economic and technical feasibility of using sulfur-modified zero-valent iron to reduce nitrate concentrations in the municipal water supply to acceptable levels [5]. A schematic diagram of the process is presented in the following Figure 3 below.

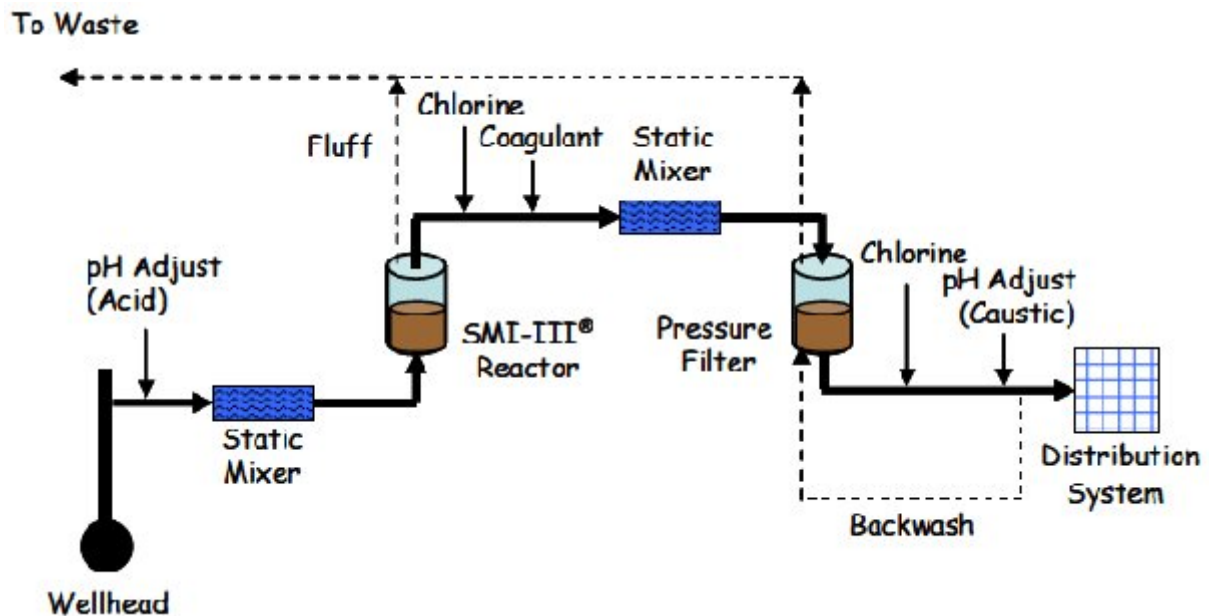

Figure 3. Conceptual schematic of an integrated SMI-III[®] /coagulation/filtration treatment system

The following Figure 4 shows some of the equipment in place for the purpose of gathering the appropriate data.



Figure 4: SMI-III[®] media column investigation photographs

The report concluded that sulfur-modified zero-valent iron was an economical method for a municipal water supply to reduce nitrate concentrations to acceptable levels [5]. The report concluded, "It is foreseen that the greatest benefit of this technology (sulfur-modified iron) is that

it does not produce a costly brine stream as do the currently accepted nitrate removal technologies of ion exchange and reverse osmosis. This investigation confirmed that nitrate reduction via sulfur-modified iron is independent of the HLR (hydraulic loading rate). Future sulfur-modified iron treatment systems can be designed without restriction of the reactor vessel dimensions. Future vessels can be adapted to existing site constraints without being limited to height-to-width ratios that would exist if nitrate reduction were to depend on hydraulic loading rate."

While strontium-90 is a less mobile constituent at the Hanford Site, it has been successfully sequestered along the Columbia River by in situ barriers that used apatite as the main ingredient. If it would occur in groundwater that was pumped from the subsurface, it would be automatically treated by any system that used sulfur-modified zero-valent iron as part of the treatment process. This is because of the strong reduction reaction conditions produced by the zero-valent iron.

For uranium, a number of conventional ZVI barriers have been demonstrated, including [6]:

- Bodo Canyon Disposal Site, La Plata County, Colorado—a number of PRBs (permeable reactive barriers, composed of ZVI, copper wool, and steel wool) were used to treat arsenic, molybdenum, selenium, uranium, vanadium, and zinc. The barrier containing ZVI operated from August 1999 until June 2004 (when flow ceased from the seep and remediation was no longer needed). It maintained effluent uranium concentrations of less than 0.01 mg/L, and was highly effective in treating contaminants.
- Cotter Corporation Uranium Mill, Cañon City, Colorado—a ZVI PRB was used to treat molybdenum and uranium. Though the barrier eventually failed for molybdenum, uranium concentrations remained at less than 0.006 mg/L. It was found that the ZVI was clogged by mineral precipitants. Modifications, including a pretreatment zone composed of coarse gravel and ZVI, were suggested.
- Fry Canyon Site, Fry Canyon, Utah—a PRB of ZVI, amorphous ferric oxide (AFO), and phosphate rock was used to treat uranium. The ZVI barrier has been the most effective, removing 99.9% of uranium.
- Mecsek Ore Site, Pecs, Hungary—a PRB composed of ZVI and shredded cast iron was used to treat uranium, and concentrations within the groundwater in 2003 were reduced to less than 1% of the influent value after passing through the barrier.
- Monticello Mill Tailings Site, Monticello, Utah—a ZVI PRB was used to treat uranium, arsenic, manganese, molybdenum, selenium, vanadium, and nitrates. Results show that the barrier was effective in treating the contaminants. Nearly all of the uranium, arsenic, manganese, molybdenum, selenium, and vanadium were removed from the groundwater, and nitrate, molybdenum, and manganese were greatly reduced. Since 2000, contaminants have been reduced to below detectable levels.
- Rocky Flats Environmental Technology Site (Solar Ponds Plume), Golden, Colorado—a barrier composed of ZVI and wood chips was used to treat nitrate and uranium.

Remediation goals required a reduction of uranium from 20-28 pCi/L to 10 pCi/L. Surface stream samples below 10 pCi/L for uranium indicate that the PRB is working properly.

- Y-12 Site, Oak Ridge, Tennessee—a barrier composed of ZVI and peat materials is being used to treat uranium, technetium, and nitric acid. A funnel and gate barrier failed due to leaking. A continuous trench was subsequently installed and has shown that uranium and technetium concentrations have decreased, but because of reactions with groundwater constituents, the lifespan of the ZVI wall may be significantly shorter than expected.

Overall, these results strongly support the case for using conventional ZVI as an effective reductant for radionuclides, such as uranium. This also includes technetium. In a kinetic study of sulfur-modified zero-valent iron for the reduction and sequestration of technetium, Pacific Northwest National Laboratory (PNNL) concluded that, "Under reducing conditions, TcO_4 is readily reduced to TcIV, which forms highly insoluble oxides such as $\text{TcO}_2 \cdot n\text{H}_2\text{O}$. However, (re)oxidation of TcIV oxides can lead to remobilization. Under sulfidogenic conditions, most TcIV will be reduced and immobilized as Tc_2S_7 , which is less readily remobilized, even under oxic conditions. This process should be favored by stimulation of sulfidogenic conditions." The sulfur-modified iron provides the sulfur, together with the iron, to maintain this stable sequestration of technetium.

CONCLUSIONS

Many DOE remediation sites have chemicals of concern that are compounds in higher oxidation states, which makes them both more mobile and more toxic. The chemical reduction of these compounds both prevents the migration of these chemicals and in some cases reduces the toxicity. It has also been shown that zero-valent iron is a very effective substance to use in reducing oxygenated compounds in various treatment processes. These have included the treatment of halogenated hydrocarbons in the form volatile organic compounds used as solvents and pesticides. Zero-valent iron has also been used to reduce various oxidized metals such as chromium, arsenic, and mercury in order to immobilize them, decrease their toxicity, and prevent further transport. In addition, it has been used to immobilize or break down other non-metallic species such as selenium compounds and nitrates.

Of particular interest at several DOE remediation sites is the fact that zero-valent iron is very effective in immobilizing several radioactive metals which are mobile in their oxidized states. These include both technetium and uranium. Also of concern to DOE at the Hanford Site are certain chlorinated hydrocarbons, particularly carbon tetrachloride, and hexavalent chromium. As a result of these and other studies demonstrating the cost-effectiveness of sulfur-modified iron in treating technetium and other hazardous compounds in Hanford Site groundwater and its cost-effectiveness in reducing nitrate, the Richland Operations Office of the Department of Energy issued a change order to the Central Plateau Contractor providing for the testing of sulfur-modified iron in a mobile pilot unit at the Hanford Site. Further testing is anticipated to produce refinements in operating conditions and further optimization of the existing process.

REFERENCES

1. DOE/RL-2011-119 Revision 0, *Hanford Site Environmental Report for Calendar Year 2011*, September 2012, U.S. Department of Energy, Assistant Secretary for Environmental Management.
2. James T. Nurmi, Paul G. Tratnyek, Vaishnavi Sarathy, Donald R. Baer, James E. Amonette, Klaus Pecher, Chongmin Wang, John C. Linehan, Dean W. Matson, R. Lee Penn, and Michelle D. Driessen, *Characterization and Properties of Metallic Iron Nanoparticles: Spectroscopy, Electrochemistry, and Kinetics*, *Environ. Sci. Technol.*, 2005, 39 (5), pp 1221–1230.
3. Anirban Basu and Thomas M. Johnson, *Determination of Hexavalent Chromium Reduction Using Cr Stable Isotopes: Isotopic Fractionation Factors for Permeable Reactive Barrier Materials*, *Environ. Sci. Technol.*, 2012, 46 (10), pp 5353–5360.
4. Lee JW, Cha DK, Oh YK, Ko KB, Song JS; *Zero-valent Iron Pretreatment for Detoxifying Iodine in Liquid Crystal Display (LCD) Manufacturing Wastewater*; *J Hazard Mater.* 2009 May 15;164(1):67-72. Epub 2008 Aug 9.
5. City of Ripon, California, *Proposition 50 Project: Integrated Nitrate and Arsenic Treatment Demonstration FINAL REPORT*, ID No. P50-3910007-055, February 2010.
6. Bronstein, Kate. 2005. *Permeable Reactive Barriers for Inorganic and Radionuclide Contamination*. Prepared for U.S. EPA, Washington DC.
7. Paul Tratnyek, Brad Tebo, Jim Szecsody, and Jim McKinley; *Techneium Reduction and Permanent Sequestration by Abiotic and Biotic Formation of Low-Solubility Sulfide Mineral Phases*; Pacific Northwest National Laboratory New Start Project (ERSP 109640), 2009.