

Multimode 155Mbps 850nm LED Optical Transceiver

Features

- 850nm LED Transmitter / GaAs PIN receiver
- Industrial standard 1x9 pin footprint
- Duplex SC/ST/FC single mode connector interface
- Receiver signal detect function
- PECL/LVPECL logic interface, DC or AC coupling
- Single supply 5V/3.3V
- RoHS available

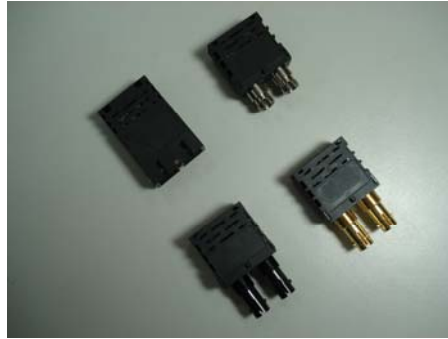

Specifications

Parameter		Symbol	Min.	Typ.	Max.	Unit
Transmitter						
Data Rate (NRZ)		B	2	100	190	Mb/s
Optical Output Power (avg.) ^{(1) (2) (4)}		P _o	-18	-	-	dBm
Extinction Ratio		ER	8.3	-	-	dB
Optical Wavelength		λ _c	820	850	880	nm
Spectral Width		Δλ	-	-	60	nm
Output Rise Time (10-90%)		t _r	-	-	8	ns
Output Fall Time (10-90%)		t _f	-	-	10	ns
Data Input ⁽⁵⁾	DC Coupled	V _{IL} V _{IH}	V _{CC} -1.810 V _{CC} -1.165	- -	V _{CC} -1.475 V _{CC} -0.880	V V
	AC Coupled (Differential)	V _I	0.25	-	1.6	V
Supply Voltage		V _{CC}	3.10 4.75	3.3 5.0	3.50 5.25	V
Supply Current		I _{CC}	-	-	110	mA
Receiver						
Data Rate (NRZ)		B	2	100	190	Mb/s
Optical Input (avg.) Sensitivity ^{(1) (4)}		P _{IN}	-29 (2M)	-35 (100M)	-22(190M)	dBm
Optical Wavelength		λ	8200	850	880	nm
Output Rise Time (10-90%)		t _r	-	1.3	2.5	ns
Output Fall Time (10-90%)		t _f	-	1.6	2.5	ns
Data Output ⁽⁵⁾	DC Coupled	V _{OL} V _{OH}	V _{CC} -1.840 V _{CC} -1.045	- -	V _{CC} -1.62 V _{CC} -0.88	V V
	AC Coupled (Differential)	V _I	0.6	-	1.8	V
Signal Detect Asserted (avg.)		P _A	-	-	-29	dBm
Signal Detect Deasserted (avg.)		P _D	-37	-	-	dBm
Hysteresis		P _{HYS}	-	3	-	dB
Supply Voltage		V _{CC}	3.10 4.75	3.3 5.0	3.50 5.25	V
Supply Current		I _{CC}	-	-	100	mA

Notes :

- (1) With 0.275 NA, 62.5/125μm fiber.
- (2) Driven with a differential signal.
- (3) Eye mask diagram is compliant to ITU-T G.957 Eye Diagram.
- (4) 2²³ -1 PRBS, BER= 10⁻¹⁰.
- (5) Compatible with LVPECL and PECL logic levels.
- (6) The transmitter output should not be viewed directly.

Absolute Maximum Ratings

Parameter		Min.	Max.	Unit
Operating Temperature	-1	0	70	°C
	-2	-40	85	°C
Storage Temperature		-40	100	°C
Lead Soldering Limits		-	240/10	°C /sec
Supply Voltage	5V	-0.2	7	V
	3.3V	-0.2	4	V

Ordering Information

SNS-TR85MM1 - 1 S □ □ □ 9 R 1 □ □ □ -- G for RoHS

Operating Temperature Range :

1 : 0 ~ 70°C

2 : -40 ~ 85°C

Data Coupling & SD Output Level :

Symbol	Tx Coupling	Rx Coupling	SD
C	AC	DC	PECL
D	AC	DC	TTL
E	AC	AC	PECL
F	AC	AC	TTL
G	DC	DC	PECL
H	DC	DC	TTL
I	DC	AC	PECL
J	DC	AC	TTL

Supply Voltage :

5 : 5V

3 : 3.3V

Connector Type :

SC : SC Connector

FC : FC Connector

ST : ST Connector

Multimode 155Mbps 850nm LED Optical Transceiver

Outline Drawing

UNIT : mm

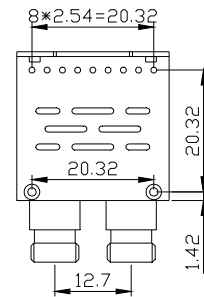
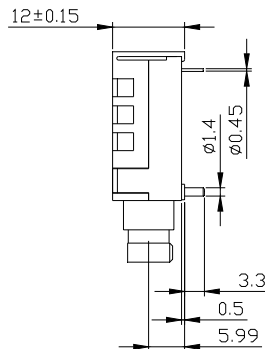
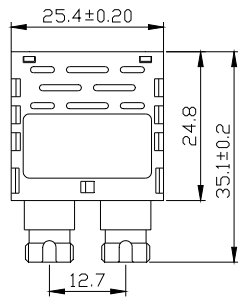
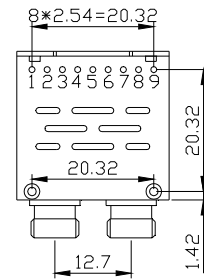
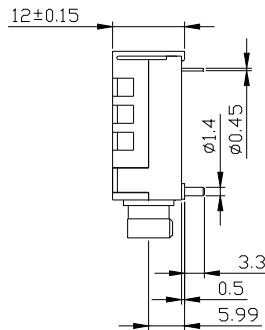
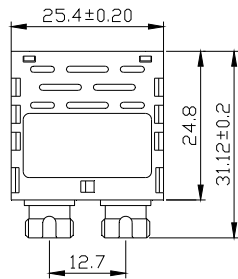
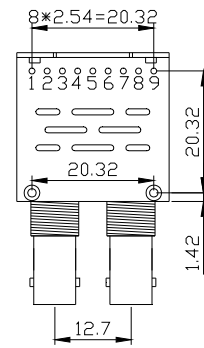
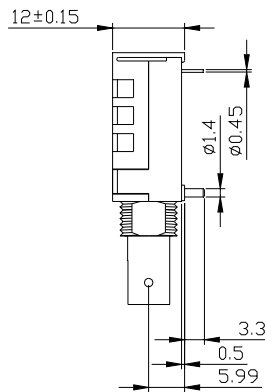
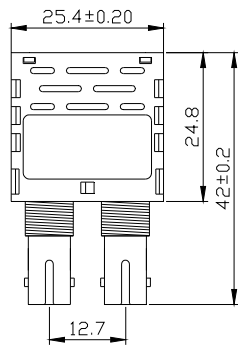
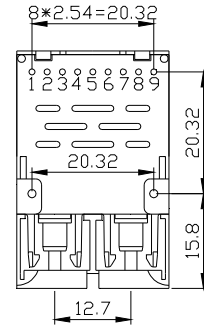
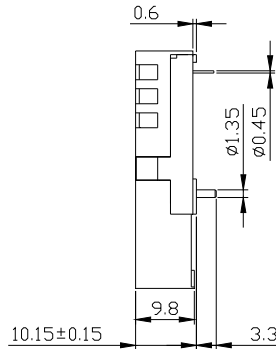
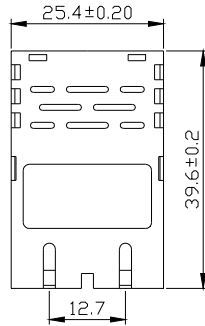

Pinout Description

Pin No.	Symbol	Description
1	V _{EER}	Receiver Ground
2	RD+	Receiver Data Out
3	RD-	Receiver Data Out (Inverted)
4	SD	Receiver Signal Detect
5	V _{CCR}	Receiver Power Supply (5V/3.3V)
6	V _{CCT}	Transmitter Power Supply (5V/3.3V)
7	TD-	Transmitter Data In (Inverted)
8	TD+	Transmitter Data in
9	V _{EET}	Transmitter Ground

Application Notes

Recommended AC Coupling Interface Circuit :

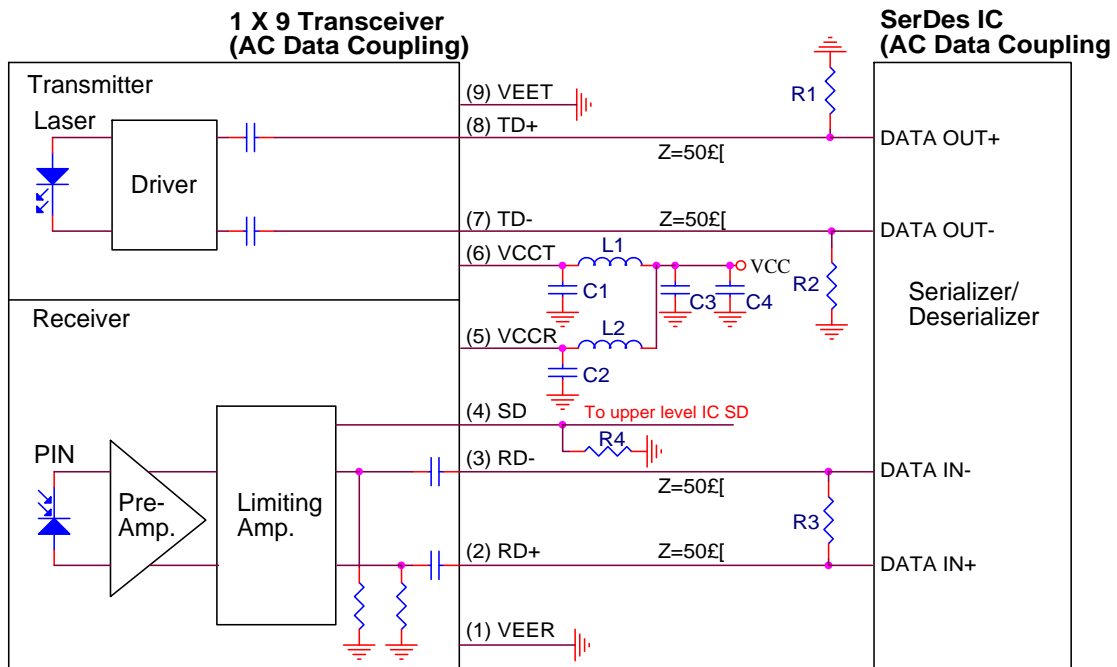

L1=L2=1 μ H or ferrite bead
 C1=C2=C3=0.1 μ F
 C4=10 μ F
 R1, R2, R3 depends on SerDes IC specification.
 (Consult the SerDes IC application information)
 R4=510 Ω

NOTE;G
 1. Transmission line characteristic impedance Z=50 Ω .
 2. R1, R2, R3 as close to SerDes IC as possible.

Multimode 155Mbps 850nm LED Optical Transceiver

Recommended DC Coupling Interface Circuit :

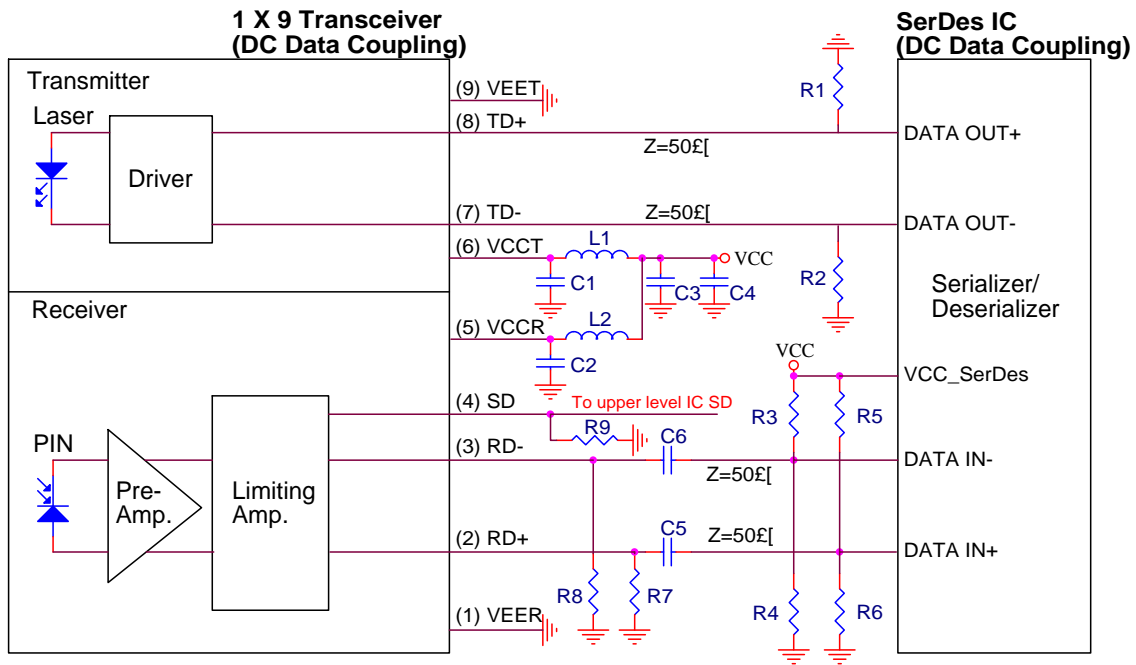

- L1=L2=1£gH or ferrite bead
- C1=C2=C3=C5=C6=0.1£gF
- C4=10£gF
- R1, R2, R3, R4, R5, R6 depends on SerDes IC specification.
(Consult the SerDes IC application information)
- R7=R8=270£[(VCC=3.3V)
=510£[(VCC=5V)
- R9=510£[

- NOTE;G
1. Transmission line characteristic impedance Z=50£[.
 2. R1, R2, R3, R4, R5, R6 as close to SerDes IC as possibl
 3. R7, R8 as close to 1X9 Transceiver as possible.