

D/ Cross Slicer serie



D/ Cross Slicer Automatic Automatic bread slicer for bakery shops

The D/ Cross Slicer series of Daub offer the perfect slicing option for any retail, small wholesale, large retail or in-store bakery. Equipped with Daub's patented unique and proven Cross slice system that cuts bread under an angle with a longer stroke of the blades resulting in faster slicing operations (even of fresh bread) and a long durability of blades. Combination of a solid base frame and light weight components create stability and silence, even after many years in operation.

Many years of operational experience have clearly proven that slicing blades in Daub's patented Cross Slice System last up to three times longer compared to vertical placed blades in standard slicing equipment; while replacement of blades takes the same time as with standard slicing equipment.

All Cross Slicers are equipped for breads of up to 44 cm long and 16 cm height. An optional user-friendly bag blowing system for plastic bags can be placed on left, right or both sides of the machine.

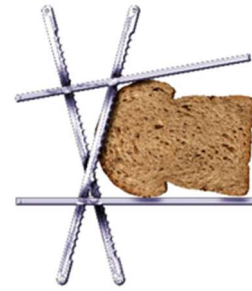

This innovative slicer is equipped with Daub's unique and proven Cross-Slice system. The bread is cut under an angle with a longer stroke of the blades, which results in faster slicing (even fresh bread).



Excellent cleaning, service and maintenance access by hinged front table.



Transparent in-feed cover with automatic on-off switch for maximum safety.



Optional bag blowing device which can be placed on the right or left side of the machine.

D/ Cross Slicer Automatic

Automatic bread slicer for bakery shops

- Automatic slicing with variable pressure regulation
- Equipped with Daub's unique and proven Cross-Slice System
- Up to three times longer life span of cross slicer blades compared to conventional slicing systems
- Accurate slicing through all kinds of bread (even fresh bread)
- Stable steel frame structure with lightweight moving parts for silent operation, even after many years of use
- Choice of cutting height 12 or 16 cm
- Hinged front table for easy cleaning, maintenance and replacement of blades
- Easy accessible crumb tray collector at the front side
- Simple removing or positioning of optional bag blowing device
- Max. bread size (WxDxH) 44 x 26 x 16 cm
- Slice thickness 10, 11, 12 or 14 mm (other on request)
- Transparent infeed safety cover

Options

- Teflon coated blades for fruit bread
- Stainless steel blades for maximum hygiene
- Electronic oil lubrication for rye bread
- Single phase electric components
- Safety outfeed curtain
- Transparent outfeed safety cover *
- Bag blowing device on left or right side
- Continuously pressed-on button
- Emergency safety button
- Special slice thickness
- Lockable swivel wheels for effortless positioning
- Not in combination with bag blowing device

Power 0.6 kw, 1- or 3-phase, net weight 165 kg
WxDxH 57 x 93 x 112 cm

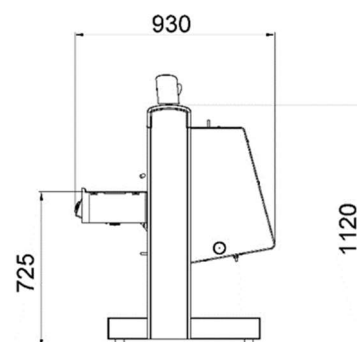
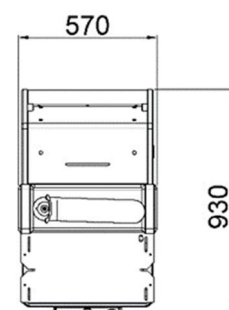
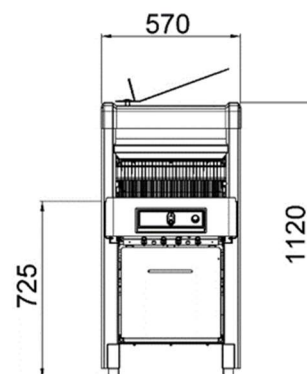

Voltage	Hz	Phase	Ampere	Wattage
400 - 460 V	50 - 60 Hz	3 phase / ground / neutral	2A	0.4 kW
200 - 270 V	50 - 60 Hz	3 phase / ground	3A	0.4 kW
200 - 270 V	50 - 60 Hz	3 phase / ground	5A	0.6 kW
400 - 460 V	50 - 60 Hz	3 phase / ground	2A	0.4 kW