



*International J70 Class Association*

**EQUIPMENT REGULATIONS**

[ Version: 2019-11 ]

**1. STATUS OF THESE REGULATIONS**

- 1.1. These Equipment Regulations are intended to be binding on all boats except as otherwise indicated herein.
- 1.2. Provisions of these Regulations may be altered with approval of the IJ70CA Executive Committee; any such changes should be specified in the Notice of Race and/or the Sailing Instructions.

**2. EVENT EQUIPMENT RULES**

All **boats, sails, portable equipment,** and mandatory **personal equipment** must be in compliance with the following from the time described in ER 4.1 below until the conclusion of the event:

- 2.1. The Equipment Rules of Sailing (ERS) (published at <https://www.sailing.org/documents/equipmentrules/>);
- 2.2. The current International J/70 Class Rules (CR) (published at <http://j70ica.org/class-office-rules/>);
- 2.3. The current J/70 Building Specification (published at <http://j70ica.org/class-office-rules/>);
- 2.4. These Equipment Regulations (ER) (published at <http://j70ica.org/class-office-rules/>).

**3. PERSON IN CHARGE**

Each owner/charterer shall designate one person in charge pursuant to RRS 46. The person in charge is responsible for providing all relevant documents and other information, completing all required inspection forms, making inspection appointments, representing the boat during the inspection process, and responding to requests by the Event Technical Committee.

#### 4. COMPLIANCE

- 4.1. At all times after inspection, the owner and any other person in charge shall ensure that the **boat, sails**, and all items of required equipment are maintained to comply with the Event Equipment Rules, and that the boat's Manufacturer's Declaration remains valid. This modifies RRS 78.1.
- 4.2. **Boats, sails**, and all items of required equipment are subject to inspection for compliance with the Event Equipment Rules at any time after ER 4.1 above. Inspections may occur with or without prior notice.
- 4.3. The boat's required equipment used and carried while *racing*, the **sails**, the **rig**, and **appendages** shall not be removed from boats after inspection until the end of the event, except pursuant to ER 10. Keels and rudders shall not be removed from the water except pursuant to ER 10.

#### 5. REQUIREMENTS PRIOR TO EVENT CHECK-IN

Prior to check-in at the event, the person in charge shall:

- 5.1. Provide the Event Technical Committee with a current and valid copy of the boat's IJ70CA Manufacturer's Declaration (see CR A.10-A.12);
- 5.2. Ensure that any bow numbers and any other OA-provided markings are affixed to the boat (see ER 6);
- 5.3. Submit a J/70 Class Rules Compliance Declaration Form (see ER 7);
- 5.4. If required in the NOR and/or SI, make arrangements for the **boat** to be inspected (see ER 8).
- 5.5. If required in the NOR and/or SI, make arrangements for the **sails** to be inspected (see ER 9);

#### 6. BOW NUMBERS & OTHER OA-PROVIDED MARKINGS

- 6.1. If specified in the NOR and/or SIs, event bow numbers shall be provided by the OA and will be at least 381mm (approximately 15 inches) in height.
- 6.2. Bow numbers shall be affixed so that the leading edge of the number is no more than 216mm from the of the bow and the top edge of the number(s) is within 127mm of the **sheerline**. See Appendix A for details.
- 6.3. If specified in the NOR and/or SIs, sprit numbers shall be affixed on each side of the sprit within 50mm/2in of the end of the pole.
- 6.4. Event limitation marks, stickers, or stamps may be applied to the **boat, sails** or **equipment** during the inspection process by the inspection team.

- 6.5. Boats may be required to display advertising chosen and supplied by the OA from the close of check-in through the end of the event.
- 6.6. Any accidental removal of the items described in this ER 6 shall be promptly reported to the Event Technical Committee.

## 7. J/70 CLASS RULES COMPLIANCE DECLARATION FORM

- 7.1. The person in charge shall complete and submit a signed J/70 Class Rules Compliance Declaration Form prior to check-in for the event.
- 7.2. The IJ70CA, the OA, and/or the Event Technical Committee will determine the format and content of the Compliance Declaration Form. The OA will notify competitors whether the Compliance Declaration Form may be completed online or in hard copy. The OA will distribute the form (or a link to the form) shortly before the event. Competitors having trouble accessing the Compliance Declaration Form should contact the OA or a member of the Event Technical Committee for assistance.
- 7.3. Equipment Inspectors will be available during the inspection period designated in the NOR to answer questions about the Compliance Declaration Form or the required items.
- 7.4. Competitors are reminded that Event Equipment Rules requirements or regulations not listed on the Compliance Declaration Form may be the basis for inspection and/or protest in the event of non-compliance. Pursuant to ER 4, boats are subject to inspection at any time throughout the event.

## 8. BOAT INSPECTION

- 8.1. If required in the NOR and/or SI, the person in charge shall arrange for an inspection time for the **boat** using the scheduling tools provided by the OA.
- 8.2. The NOR and/or the SI may specify that boat inspection must occur with the boat out of the water.
- 8.3. At least two crew from each boat shall attend the inspection appointment.
- 8.4. All equipment and **corrector weights** shall be made accessible to inspectors.
- 8.5. **Boat** inspection may include but is not limited to: checking conformance with a prior Manufacturer's Declaration; inspecting standing and/or running rigging and associated fittings; testing lifeline tension; checking deck layout, required equipment, personal flotation devices, hull shape compliance, and keel and rudder shape compliance; and boat weighing.
- 8.6. Boat weighing:

- 8.6.1. Any boat not having a current Manufacturer's Declaration should contact a Class Measurer for weighing and inspection prior to the event. It may not be possible to complete the process for obtaining a Manufacturer's Declaration at the event.
- 8.6.2. The NOR and/or SI may specify that all boats must be weighed.
- 8.6.3. Any boat may be requested to be weighed by an Equipment Inspector, the Event Technical Committee, or the OA at any time during the event.
- 8.6.4. Boats will be weighed dry according to the provisions of CR C.6.1.
- 8.6.5. In general, only one weighing attempt shall be permitted; no optimization attempts are allowed.
- 8.6.6. In cases where **corrector weights** need to be installed: (a) the **corrector weights** will be weighed separately on a suitable scale; and (b) the installation of the **corrector weights** shall be according to CR Appendix H-2 and confirmed by the Measurer or Equipment Inspector in charge.
- 8.7. Prior to checking in each boat must either submit or have submitted on its behalf a signed and completed boat inspection checklist according to procedures established by the OA or the Event Technical Committee.

## 9. SAIL INSPECTION

- 9.1. If required in the NOR and/or SI, the person in charge shall arrange for an inspection time for the **sails** using the scheduling tools provided by the OA.
- 9.2. **Sails** to be carried while *racing* shall arrive at the sail inspection area 5 minutes before each scheduled appointment, with at least two crew members to assist the inspections.
- 9.3. **Sails** shall be presented for inspection in dry condition with leech, luff and foot cords untied and with battens removed.
- 9.4. After inspection, **sails** shall be immediately returned to the boat and kept on the boat until the end of the event pursuant to ER 4.
- 9.5. Prior to checking in each boat must either submit or have submitted on its behalf a signed and completed sail inspection checklist according to procedures established by the OA or the Event Technical Committee.

## 10. REPAIR, REPLACEMENT AND ALTERATION OF EQUIPMENT

- 10.1. Any repair, replacement or alteration of the **boat, sails**, or required equipment after inspection and until the end of the event shall require the prior approval of the Event

- Technical Committee before *racing* and may be subject to re-inspection before further *racing*.
- 10.2. Repairs, replacement, or alterations required on the water may be approved each day after *racing* provided the Event Technical Committee or Race Committee is notified before *racing*.
  - 10.3. Procedures (including any forms) for requesting the approval required under this ER 10 may be determined by the OA and/or the Event Technical Committee.

## 11. PROTESTS

- 11.1. The Event Technical Committee may protest a boat for violations of these Equipment Regulations. This adds to RRS 60.4.
- 11.2. Violations of the Equipment Regulations and/or the Event Equipment Rules prior to the start of *racing* may be reported and protested by the Event Technical Committee after the end of the check-in time specified in the NOR and/or SI, as if it were discovered after *racing* on the first day on which races are completed.
- 11.3. The protest committee or international jury may impose suitable penalties, other than disqualification, for violations of these Equipment Regulations or the Event Equipment Rules listed in ER 2.

## APPENDIX A: BOW NUMBER POSITIONING

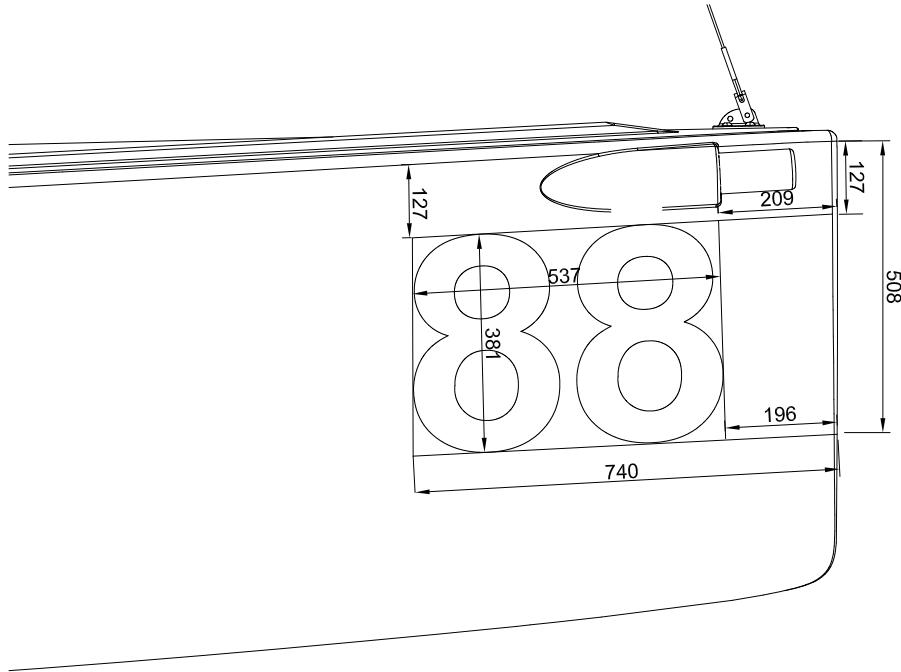

**381mm / 15 inch**

J/70 Class Bow Number Location & Size #1

Standard number - height = 381mm (15")  
 Dimensions in mm  
 6-11-2018

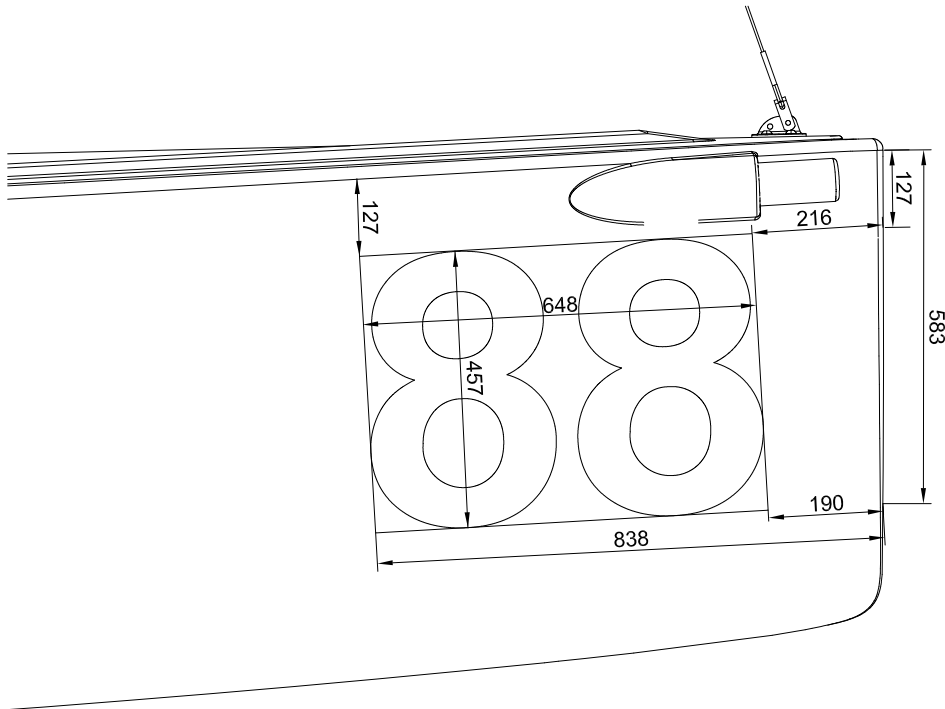

**457mm / 18 inch**

J/70 Class Bow Number Location & Size #2

Large number - height = 457mm (18")  
 Dimensions in mm  
 6-11-2018