

FIELD INSTALLATION INSTRUCTIONS FOR FLOOD BARRIERS

TOOLS LIST

- CONCRETE HAMMER DRILL
- 3/16" AND 1/2" MASONRY BITS (SEVERAL OF EACH)
- SHOP VAC AND BROOM
- PUFFING DEVICE- (A straw, turkey baster or similar device)
- HIGH SPEED DRILL WITH 1/2" DRILL BIT.
- NUT DRIVERS 5/16" & 7/16
- CORDLESS DRILL
- HAMMER
- LARGE STANDARD & PHILLIPS HEAD SCREW DRIVERS OR BITS
- MEASURING TAPE
- TAMP-IN SETTING TOOL
- LARGE VISE-GRIP STYLE PLIERS
- GREENLEE HOLLOW BLOCK SETTING TOOL (Only on specific projects)

INSTALLTION OF FLOOD BARRIERS:

1. Start by laying out all flood-barriers in front of openings. Each barrier should be marked with a number, which corresponds with an opening number on the projects original shop drawings. Please note that some openings have more than one flood panel: in which case, the panel will be marked with an opening number and a letter. [Example: Opening one has 3 panels, they would be marked 1, 1A, and 1B.]

If the opening is greater than 8'-0" in width, it will also have a diagonal brace every 4'-0" on center. [A diagonal tube cut at 45 degree angels at both ends with feet on one side.] Most "cross braces" are interchangeable and are not marked, but some braces go in a specific location. If this is the case, both the barrier and the cross brace will have identifying markings of some kind to signify their location.

The original shop drawings will have a foot print of the structure, with the barrier numbers, quantities, size of each barrier, and number of cross braces. They also provide details that may aid in the installation.

2. It is very important to clean and sweep around each opening. This will prevent any dust or dirt from clogging the fasteners. If dirt or debris get into the fastener, it is almost impossible to get the screw to set.
If this happens the fastener will have to be cleared or changed, [SEE Section- What to do with a clogged or cross threaded fastener]
Once the opening has been cleaned, installation can begin.

3. Start the installation by assembling the entire barrier for each opening. If there is only one flood-barrier for the opening, skip this step and move on to the next.

Lay each flood panel face down on the ground [The side with the exposed tube should be showing] next to the corresponding section, [1 to 1A to 1B etc.], making sure that each barrier is perfectly aligned and square to its mate.

It is best to align the panels directly in the position they are to be installed. To do, this start by placing the first panel upright in front of opening, approximately ± 4 " from the edge of masonry opening. Then, gently lay the panel face down in front of its position. Next, place each additional panel face down, beside the first panel in corresponding order.

If you have to walk on the panels, be sure to step on the tubing and not the skin.

Once the panels are aligned, you will see $\frac{1}{2}$ " holes 6 " on center along each seam. Each hole gets the one $\frac{1}{4}$ " diameter screw - $5 \frac{1}{2}$ " long, two gasketed washers, and one $\frac{1}{4}$ "-20 nut or wing nut.

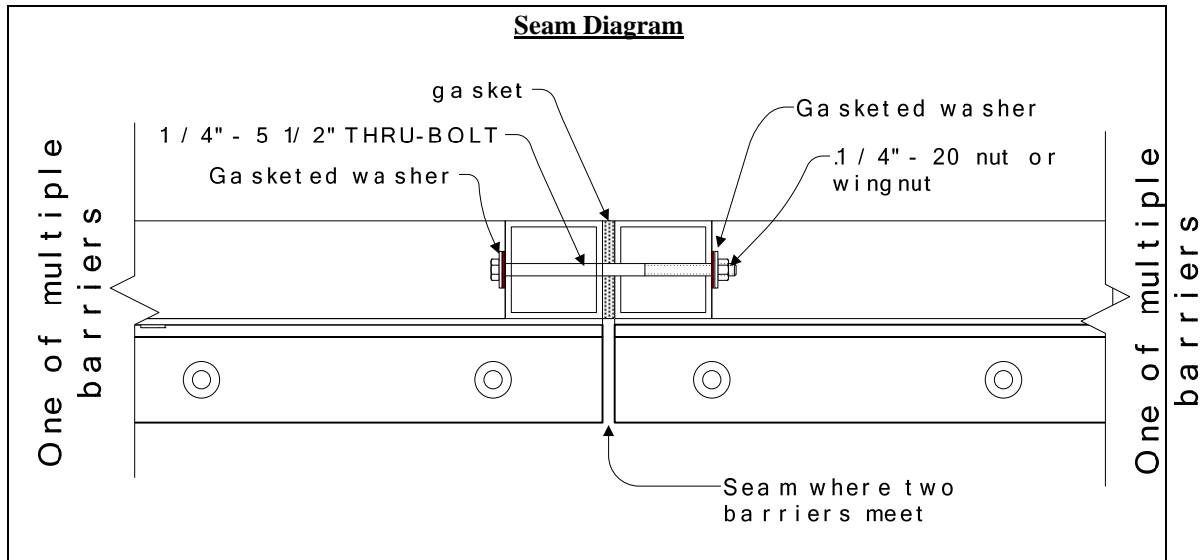

Assemble the barriers together as shown in the above diagram, with each bolt, washer and nut as shown. Using a two wrenches, tighten all the bolts, until the gasket material is completely compressed. (approximately $\frac{1}{8}$ ") To achieve this, tighten all the bolts firmly. Then go back over each bolt, tightening them a little more. Repeat this procedure until the gasket is equally compressed.

The easiest way to achieve this is to use a $\frac{7}{16}$ " nut driver on a cordless screw gun. One should be provided in the installation kit.

Once all panels have been attached you are ready to complete the installation.

- The flood-barrier is now ready to be installed. Lift the barrier into place in front of the opening. If the opening has multiple panels, at least one person will be needed per barrier panel. The entire barrier will need to be lifted in unison, making sure not to rack the system.

The barrier will need to be manipulated so that it sits equal distant in front of the masonry opening. The barrier should be lifted into position, NOT SLID, this will prevent damage to the gasket.

- NOTE: The minimum edge distance for the compression anchor is 1 1/2" but is recommended at greater than 2" to center. If there is less than 1 1/2" of edge distance the anchor will cause the concrete to crack over time, or may cause the concrete to immediately blow out.

Once the barrier is in place and the edge distance has been established, you can begin the installation.

- First install several washer-head tapcons to hold the barrier in place. The order is as follows.

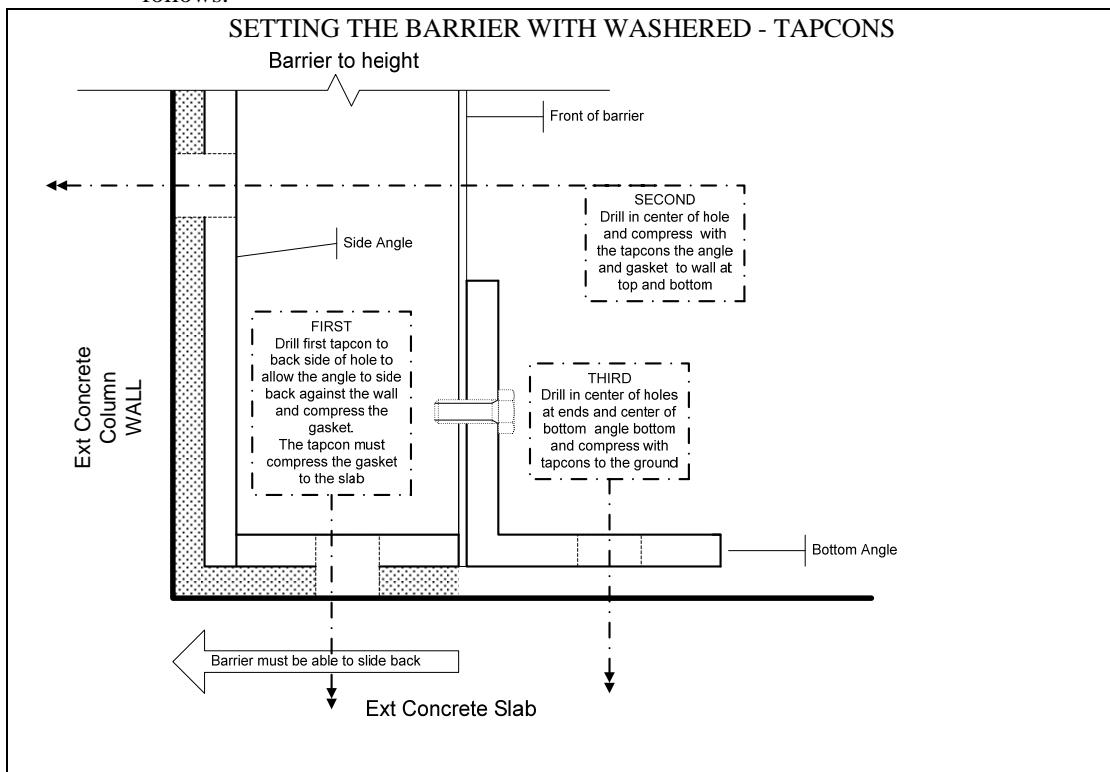

- The tapcons at the bottom of the side angles. These are the most important screws of the entire installation. You must drill the 3/16" hole for the tapcon to the back side to the thru hole. (SEE DIAGRAM BELOW). This step allows the leg of the angle against the wall to slide back and compress the gasket. The tapcon must be compressing the gasket to the ground. This may cause the barrier to rock forward, this is good. If the barrier can not be pushed back against the wall with a medium amount of force, the tapcon is too tight. If this occurs, loosen the tapcon until a medium amount of force can move the barrier against the wall.

2. Drill the angle to the wall at top and bottom holes. These holes are to be drilled on the center line. The tapcons should then be inserted and angle and gasket should be completely compressed against the wall.
 3. Drill the bottom angle at the floor, at the ends and middle of each panel. These holes are to be drilled on the center line, and the tapcons tightened until the gasket is compressed
5. Once the barrier has been tacked in place with the tapcons, use a ½” diameter concrete bit and mark all of the exposed holes. Drill only about ¾” into the concrete. Do not forget the cross braces, if applicable.
 6. After all holes have been marked, remove tapcons and move the barrier out of the area. Loosen the bolts that attach the side angles to the barrier so gasket is not compressed.
 7. Finish drilling all of the holes to depth, [SCREW SIZE PLUS 1/8”], along with the tapcon holes.
 8. Clean out all holes with a puffer and shop vac, making sure to remove all debris and dust.
 9. Set all tamp-ins with hammer and setting tool. Fasteners go cone side down.
 10. Put screws in fasteners and tighten down fairly tight.
 11. Store barriers with gasket up.

INSTALLATION PROCEDURES

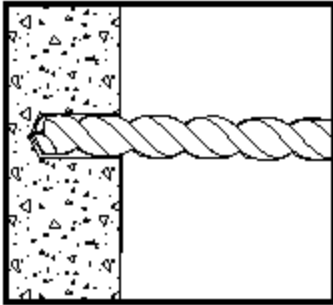

Drill a hole into the base material to the required depth. The tolerances of the drill bit used should meet the requirements of ANSI Standard B212.15.

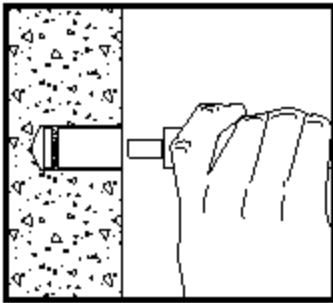

Blow the hole clean of dust and other material. Insert the anchor into the hole. Position the setting tool in the anchor.

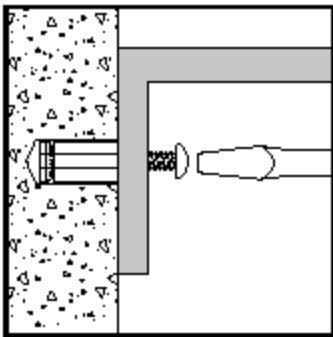

Using the tool, set the anchor by driving the lead sleeve over the cone using several sharp hammer blows. Be sure the anchor is at the required embedment depth so that anchor threads do not protrude above the surface of the base material. Position the fixture, insert screw or bolt and tighten.

FASTENER INSTALLATION IN TO WOOD

- If attaching the sides into a wood structure a brass wood bushing will have to be utilized.
 1. Secure barrier in place as noted above, but use wood screws instead of tapcons at wood locations.
 2. Use the 1/2" masonry bit to cut out the stucco at the wood areas. **DO NOT PENETRATE THE WOOD WITH THE 1/2" BIT.**
 3. Clean all masonry out of 1/2" holes, so only the wood is exposed. Note, that any wire or lathing may need to be cut away.
 4. In center of hole, drill a 3/8" hole with wood bit. Hole should penetrate solid wood member by 3/4"
 5. Clean out hole.
 6. Place brass wood bushing in 3/8" hole and screw in with large flat head screw driver.
 7. Finish as above