

THE  
**BARRETO**

**MODEL E622GT**  
**HYDRAULIC FRONT TINE TILLER**  
**OWNER'S/OPERATOR'S MANUAL**

CONGRATULATIONS!

You are now the proud owner of the BARRETO Model E622GT tiller. Please take a moment of your time to look over the following information. Familiarize yourself with the tiller, its characteristics, and method of operation. Pay particular attention to the safety and operating instructions.

If you have any questions or need any replacement parts in the future, please contact us at your convenience. Our toll-free phone number, fax and email are listed below and parts may be ordered through any of these methods.

THANK YOU for your patronage and confidence in BARRETO equipment.

Barreto Manufacturing, Inc.  
Innovative Equipment Engineered to Last  
66498 Hwy 203, La Grande, OR 97850  
(800) 525-7348 (541) 963-7348  
FAX (541) 963-6755  
E-Mail: [info@barretomfg.com](mailto:info@barretomfg.com)  
Web Site: <http://www.barretomfg.com>

Machine Identification Record

Barreto Customer number \_\_\_\_\_

Machine model number \_\_\_\_\_

Machine serial number \_\_\_\_\_

Engine manufacturer \_\_\_\_\_

Engine model number \_\_\_\_\_

Engine serial number \_\_\_\_\_

## TABLE OF CONTENTS

TILLER ASSEMBLY INSTRUCTIONS _____	2
SERVICE INFORMATION _____	3
BARRETO WARRANTY _____	3
HOUR METER _____	4
HONDA GX160 SCHEMATIC _____	5
SUBARU EX17 SCHEMATIC _____	6
HYDRAULIC SCHEMATIC _____	7
SPECIFICATIONS _____	8
TROUBLESHOOTING _____	9
OPERATING INSTRUCTIONS _____	10
ENGINE CONTROLS _____	11
SAFETY INSTRUCTIONS _____	12
SAFETY INSTRUCTIONS OVERVIEW _____	13
LOCATING UNDERGROUND UTILITIES _____	15
WORKSITE ASSESSMENT _____	15
CONTACT WITH UNDERGROUND UTILITIES _____	16

## ASSEMBLY INSTRUCTIONS

1. Remove the tiller from shipping crate. Please inspect immediately for any damage and notify the shipping company and Barreto Manufacturing, Inc. right away if any is found.
2. Check reservoir according to instructions in service information on the following page.
3. Fill the engine with fuel and oil according to the engine manual.
4. When documentation refers to “right side” or “left side”, it is relative to the operator’s position with both hands on the handlebars.

## SERVICE INFORMATION

1. Check the reservoir level using the sight glass on the top of the tank. If required, add to reservoir with tractor transmission hydraulic oil (AW or ISO rating of 68 is recommended). Recheck oil level after the tiller has been run and oil has been circulated through the tine motor. Routinely check level thereafter. **DO NOT OVERFILL THE TANK.**
2. Change the hydraulic oil filter after the first 50 hours of use. Change it after every 200 hours thereafter.
3. Check the tine bolts after each use and tighten as needed. Check all hydraulic fittings for leaks and tighten if necessary.
4. Tines should be changed as often as needed for the machine to do a satisfactory and efficient tilling job. Use Loctite stud and bearing adhesive/sealant on tine bolt threads to prevent loosening.
5. The grease zerk on the end of the tine frame should be greased after every 4 to 8 hours of use.
6. The grease zerks on the wheels should be greased monthly.

**IMPORTANT:** The engine is normally serviced prior to shipping. However, shipping regulations may prohibit this. Check levels and add oil and fuel as required before starting. Service according to the engine manual before starting.

**IMPORTANT:** If the couplers between the engine and the pump are moved or removed for any reason, it is **CRITICAL** that they have a 1/16” gap between them when reinstalled. Failure to have this gap will result in rapid wear and failure of your pump!

**NOTE:** It is very important to move the fuel shutoff lever to the closed position after stopping the engine. Failure to do so could cause fuel to leak down into the cylinder and crankcase. Damage resulting from this will void your engine warranty and not be covered.

**WARNING:** Running the tiller without hydraulic oil will cause serious damage to the hydraulic pump. **CHECK RESERVOIR LEVEL BEFORE STARTING THE MACHINE.**

## BARRETO MANUFACTURING, INC. EQUIPMENT WARRANTY

Barreto Manufacturing, Inc. warrants all **BARRETO** equipment to be free of defects in material and workmanship for a period of one (1) year, dating from delivery to the original user.

This Warranty is in lieu of all other warranties, whether written or implied, and is limited to:

1. Replacement of parts returned to the dealer and/or factory and determined defective upon inspection. (Replacement for parts to dealers shall be at dealer cost plus shipping charges.)
2. Time for pick-up and/or delivery, transportation or service calls by dealers is excluded. Manufacturer reserves the right to determine reasonable time required for repair.

Warranty does not apply to damage caused by abuse or neglect. Time and materials required for normal maintenance and service are also excluded from warranty coverage.

**Engines, engine accessories, batteries and tires are warranted by the original manufacturers and are not covered by the Barreto Equipment Warranty.** Wear parts such as tiller tines, sprockets, bearings, trencher chain parts including teeth, stump grinder cutting teeth & holders, etc. are also excluded unless it can be determined that a defect has contributed to premature wear.

## HOUR METER

The **DGI® TACH/HOUR** hour meter tracks the hours of machine operation in order for routine maintenance to be performed on a timely basis.

Your **DGI®** hour meter is pre-set at the **DGI®** factory to go into *Flash Alert* mode at 25-hour intervals. Although the engine manufacturer does not require changing engine oil this often, **due to heavy-duty use and extreme conditions inherent to tiller use, Barreto Manufacturing strongly recommends frequent oil changes.**

Refer to this manual for equipment service requirements and to the **Engine Manual** for engine service requirements.

While *Flash Alert* is active, hold the tip of the RESET TOOL (Key Kancel Wand) against the meter as shown. Within several seconds, the display will stop flashing indicating the Service Interval has been reset. If the wand gets lost, a small mechanic's pick-up magnet will work.

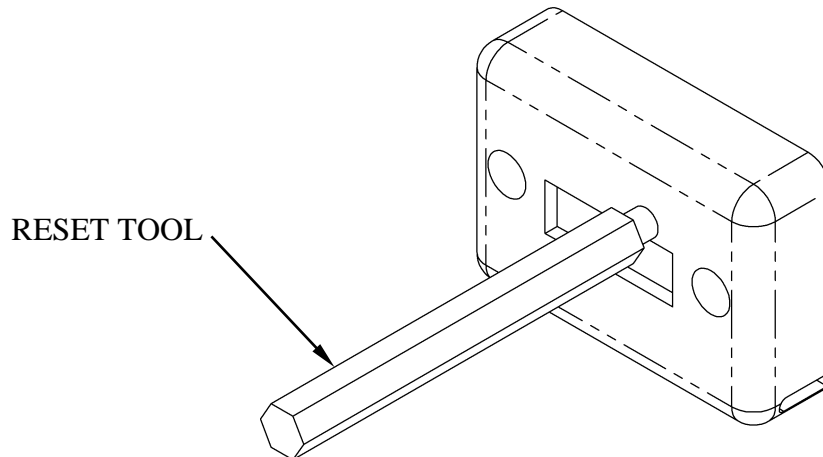

# ELECTRICAL SCHEMATIC - HONDA GX160

<Type without electric starter>

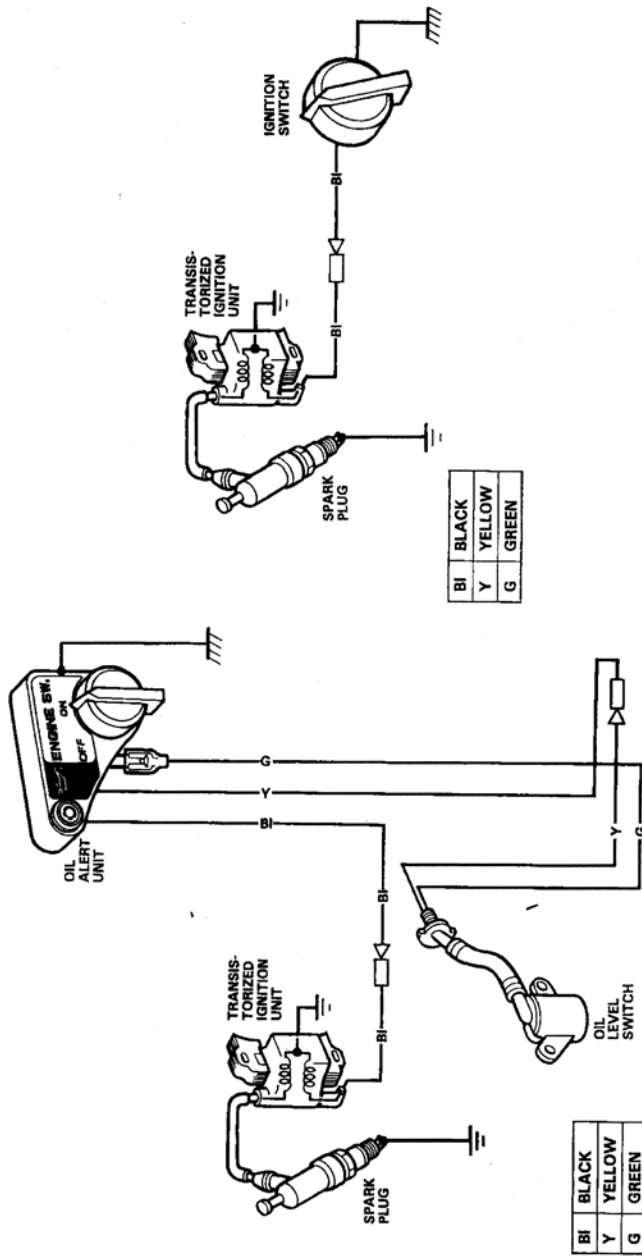

**NOTE:** Wiring diagrams may vary according to the types.

# ELECTRICAL SCHEMATIC - SUBARU EX17D

## 8. WIRING DIAGRAM

### 8-1 MODEL WITHOUT ELECTRIC STARTER (Models EX13, 17, 21 and 27)

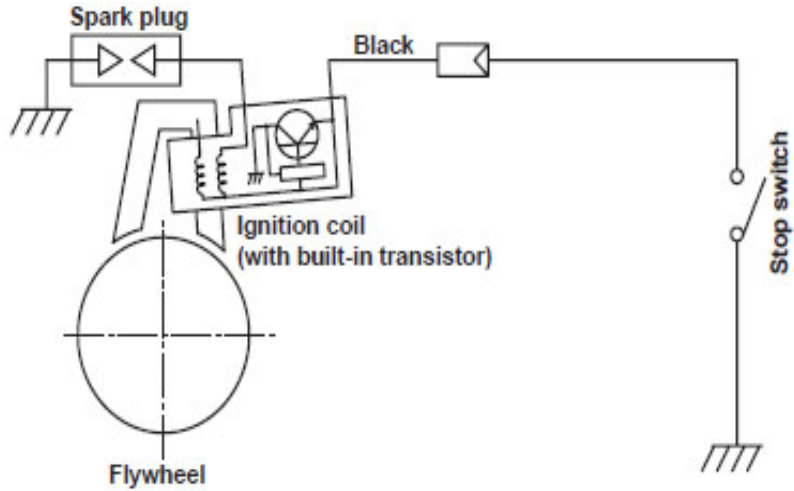
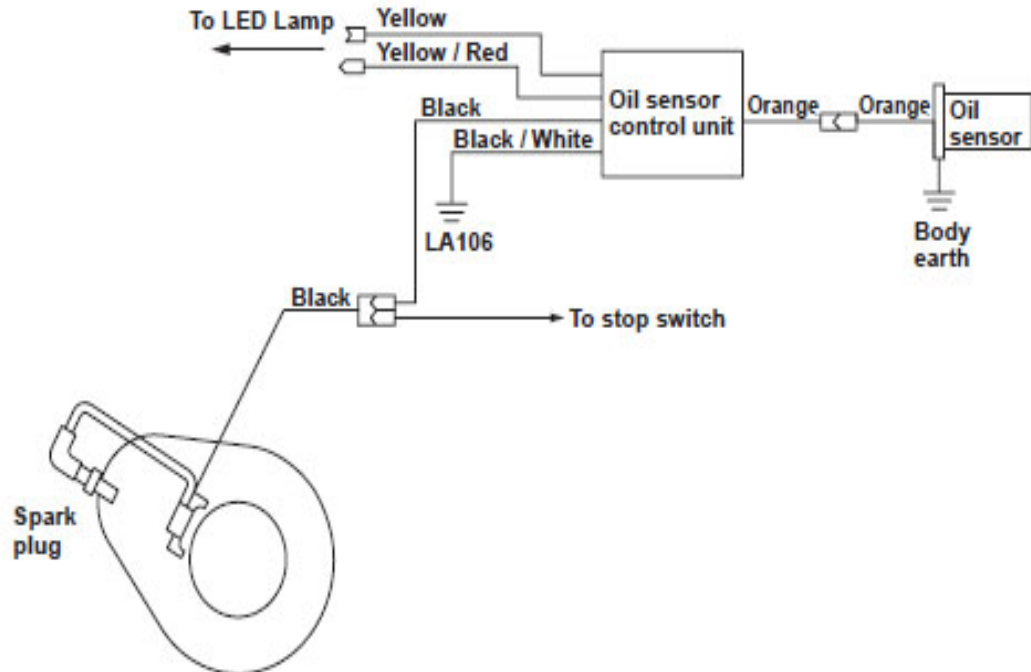
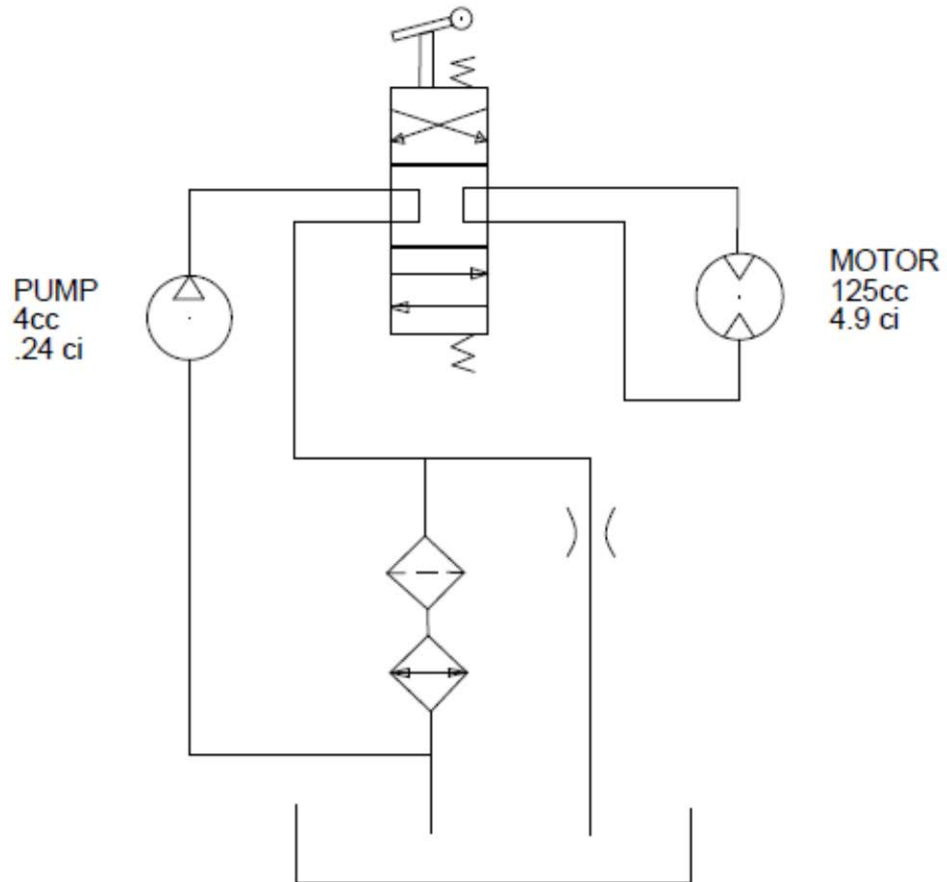

Fig. 8-1

### 8-4 MODEL WITH OIL SENSOR



# HYDRAULIC SCHEMATIC



# SPECIFICATIONS

## MODEL NUMBER

**622GT**

## DIMENSIONS

Weight

211 lbs. (95.71kg)

Height

50" (1.27m)

Length

59" (1.5m)

Width

28" (71.12cm)

## ENGINE

Engine

Honda GX 160

Optional engine

Subaru EX 17D

## FUEL

Gasoline

**POWER:** hp (kW) at 3600 RPM

H-5.5 hp (4.0kW)

**POWER:** hp (kW) at 4000 RPM

S-5.7 hp (4.2kW)

## FUEL CAPACITY

H-0.95 U.S. gallons (3.6 liters)

R-0.94 U.S. gallons (3.6 liters)

## ENGINE OIL CAPACITY

H-.63 quart (.60 liters)

R-.63 quart (.60 liters)

## HOUR METER

Standard

## HYDRAULIC SYSTEM

Reservoir Capacity

1.4 U.S. gallons (5.3 liters)

Oil Cooler

Standard

Hydraulic pump output

4 gpm (15.14 liters)



## 622GT TILLER TROUBLE SHOOTING GUIDE

CAUTION: ALWAYS USE EXTREME CARE WHEN TROUBLE SHOOTING OR MAKING ADJUSTMENTS ON THE TILLER. **STAY CLEAR OF TINES WHEN ENGINE IS RUNNING.** ALWAYS SHUT THE ENGINE OFF BEFORE DISASSEMBLING ANY COMPONENT.

### A. ENTIRE HYDRAULIC SYSTEM DOES NOT OPERATE AND THE ENGINE IS NOT UNDER LOAD

- |  |   |
|--|---|
| 1. Low hydraulic oil in tank.                    | Fill to center of sight glass.  |
| 2. Hydraulic pump-to-engine coupler has slipped. | Check for wear and replace both coupler halves and rubber spider as needed. |

### B. TINES FAIL TO ROTATE

- |                     |   |
|---------------------|---|
| 1. Tine motor worn. | Rebuild or replace motor. New motors are available from Barreto Manufacturing, Inc. |
|---------------------|---|

### C. ENGINE LUGS DOWN OR DIES AND TINES DO NOT TURN.

- |   |  |
|---|--|
| 1. Rocks or other obstruction blocking tines.   | Shut OFF engine and remove obstruction or reverse tines.   |
| 2. Tine shaft bound with wire, vines, or grass. | Shut OFF engine and remove debris, especially at the ends.   |
| 3. Outboard tine shaft bearings binding.        | Lubricate or replace bearings as needed.   |
| 4. Engine improperly tuned or maintained.       | See engine manual and correct as needed.   |
| 5. Low oil alert causes engine to shut down.    | This may occur if tilling on hills, (not advised). Level the tiller and check engine oil level. Fill if required. Oil alert should reset. See engine manual. |
| 6. Engine losing power due to wear.             | See engine manual.   |

### D. OIL LEAKS IN HYDRAULIC SYSTEM.

- |                          |                       |
|--------------------------|-----------------------|
| 1. Fittings are loose.   | Tighten as required.  |
| 2. Worn or broken hoses. | Replace as necessary. |

## TROUBLE SHOOTING GUIDE (continued)

### E. EXCESSIVE FOAMING OF HYDRAULIC OIL FROM VENT HOSE.

- |                       |  |
|-----------------------|--|
| 1. Improper oil used. | Verify that hydraulic oil used has anti-foaming additives. * |
| 2. Pump sucking air.  | Inspect and tighten fittings on intake side of pump.         |

## OPERATING INSTRUCTIONS

1. READ SAFETY INSTRUCTIONS BEFORE OPERATING!
2. Be sure engine oil and hydraulic oil are at proper levels before starting the tiller.
3. STUDY AND UNDERSTAND CONTROLS BEFORE BEGINNING OPERATION!
4. OPERATE TILLER ON LEVEL GROUND ONLY!
5. VALVE LEVER activates tines when squeezed. Tines stop when the lever is released.
6. **CAUTION!!** Tines reverse at a reduced speed when the VALVE LEVER is pushed forward. This should ONLY be done to dislodge an obstruction or back out of a corner.
7. Adjust handlebar to a comfortable position.
8. Wheels and drag bar can be adjusted to control speed and tilling depth.

## ENGINE CONTROLS

**CHOKE:** Use to aid starting the engine when it is cold.

**IGNITION SWITCH:** There are two ignition switches. One switch is located on the control panel for your convenience. The other is located on the engine. Use these to start and stop the engine.

**THROTTLE:** Use this to adjust engine speed.

**FUEL SHUT-OFF:** Use this when starting or stopping machine.

**FUEL SHUTOFF**

**THROTTLE**



**CHOKE**

**IGNITION**



**FUEL SHUT-OFF**

**THROTTLE**

## SAFETY INSTRUCTIONS

1. READ SAFETY AND OPERATING INSTRUCTIONS BEFORE OPERATING!
2. DO NOT LEAVE TILLER UNATTENDED WITH ENGINE RUNNING.
3. Always park on level surface, never on an incline.
4. USE EXTREME CAUTION IF TRANSPORTING TILLER DOWN ANY INCLINE, ESPECIALLY IF USING RAMPS OFF A PICK-UP TRUCK.
5. The VALVE LEVER on the left handlebar is for operator protection. **DO NOT TAPE DOWN OR OTHERWISE BY-PASS THIS SAFETY FEATURE!**
6. Objects may become airborne while operating tiller. Wear safety goggles, hard hat, protective footwear and hearing protection while operating or observing!
7. Rotating tines can cause serious injury. **KEEP HANDS AND FEET CLEAR!**
8. **KEEP MACHINE LEVEL** while tines are operating.
9. Buried cables or gas lines can cause serious injury or death. Contact local agencies for location.
10. Fuel exhaust and fuel fumes can cause illness or death. Operate outdoors and avoid breathing exhaust and fumes.
11. Fuel-fumes can catch fire or explode. Do not smoke or operate near flames or sparks.
12. Hydraulic oil is under extreme pressure and can get under skin and burn or poison. Check for leaks with cardboard.
13. Muffler and engine get hot enough to cause serious burns. Do not touch until cool.



# SAFETY INSTRUCTIONS OVERVIEW

USE COMMON SENSE AND PLENTY OF IT!

The VALVE LEVER on the left handlebar is for the operator's protection. All motion stops when the lever is released. **DO NOT TAPE THE VALVE LEVER UP or otherwise by-pass this safety feature!**

Call before you dig. If you do not call, you may cause an accident; suffer injuries or death; cause interruption of services; damage the environment; and/or incur project delays. Expect to be held liable for any damages caused, if you fail to call.



**DANGER:** Buried electric cables or gas lines can cause serious injury or death if struck with tines. Always determine location of utilities before tilling.



**WARNING:** Fiber optic cables convey laser light that can injure your eyesight.

STAY CLEAR of moving parts on the tiller.

Wear safety goggles and a hard hat while operating or observing!



**WARNING:** The tines may throw stones and debris.

Wear adequate hearing protection while operating or observing.



**WARNING:** Exposure to loud noise is cumulative and may permanently damage your hearing.

Wear safety boots and gloves. Wear close-fitting clothing. Contain long hair. Do not wear jewelry. Wear reflective clothing if working near traffic.

Only operate outdoors and avoid breathing engine exhaust and fumes.



**WARNING:** Engine exhaust contains carbon monoxide gas that is toxic. Breathing it can cause unconsciousness and death.

Adequate lighting is required, daylight or artificial, for safe operation of the tiller.

Allow adequate side and overhead clearances between tiller and buildings, fences, and trees.



**WARNING:** Contact with the tines while in operation will cause serious injury or even death.

Keep away from tires to avoid getting crushed.



**WARNING:** Getting run over by the tiller will cause injury.

Always leave tiller parked on a level surface.



**WARNING:** Do not park on incline. Move the tiller to a level surface.

Do not leave tiller unattended with the engine running.



## SAFETY INSTRUCTIONS OVERVIEW (continued)

Avoid inclines if at all possible.



**WARNING:** Navigating on any incline increases the danger of the tiller losing traction or rolling over, especially if the surface is wet. If you lose control, get out of the way immediately to avoid personal injury. Navigation on inclines should be especially slow and turns very gradual.

A 20° maximum incline is allowed. Honda engines have an Oil Alert system that will automatically stop the engine if tipped more than 20°.

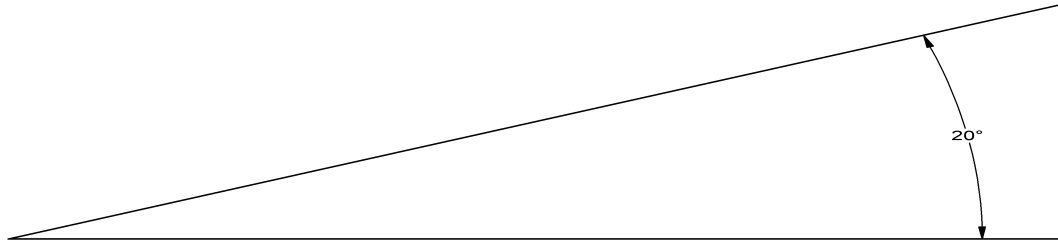

Do not operate tiller near any source of flammable dust or vapors.



**WARNING:** Sparks from the engine exhaust can cause an explosion or fire in a flammable or explosive atmosphere. Fuel fumes can catch fire or explode.

Do not operate tiller near flames or sparks.



**WARNING:** Fuel fumes can catch fire or explode.

Shut off engine and allow it to cool before refueling.



**WARNING:** Fuel fumes can catch fire or explode. Do not smoke when refueling. Do not refuel near a source of flames or sparks.

Do not touch the engine, muffler, or any of the hydraulic components until cool.



**WARNING:** Muffler and engine get hot enough to cause serious burns. For the safety of yourself and others, allow enough time for the engine, muffler, and the hydraulic fluid to cool completely before performing any cleaning or maintenance.

Avoid contact with hydraulic fluid.



**WARNING:** When machine is operating, hydraulic fluid is under extreme pressure and can get under skin and burn or poison.

Keep others away. If the job site is near a road or pedestrian path, warn and divert both motorized traffic and pedestrians. As appropriate, use traffic flag personnel, signs, cones, and lighting devices to insure safety.

Never allow anybody to ride on the tiller.

Never lift the tiller over any person at any time.



**WARNING:** If tiller should fall it would crush anybody under it.

We recommend having a fire extinguisher suitable for petrol fires in the operating area.

## DETERMINE LOCATION OF UNDERGROUND UTILITIES

OSHA CFR 29 1926.651 requires that the estimated location of underground utilities be determined before beginning excavation or an underground drilling operation. When the actual excavation or bore approaches an estimated utility location, the exact location of the underground installation must be determined by a safe, acceptable and dependable method. If any utility cannot be precisely located, the appropriate utility company must shut it off.

**Call before you dig.** If you do not call, you may cause an accident; suffer injuries or death; cause interruption of services; damage the environment; and/or incur project delays. Expect to be held liable for any damages caused, if you fail to call.



**DANGER:** Buried electric cables or gas lines can cause serious injury or death if struck with tiller tines. Always determine location of utilities before tilling.



**WARNING:** Fiber optic cables convey laser light that can injure your eyesight.

**CALL 811 TO LOCATE UTILITIES BEFORE TILLING (US. OR CANADA).** This free service will provide a “One-Call” number for the geographic area that you select. Before you start any digging project, be sure to call the local One-Call system in your area and any utility company that does not subscribe to the One-Call system. The One-Call representative will notify participating utility companies of your proposed digging activities. Utilities will then mark their underground facilities by using the following international marking codes:

Red	Electric
Yellow	Gas, oil, or petroleum
Orange	Communication, telephone, television
Blue	Potable water
Green/brown	Sewer
White	Proposed excavation
Pink	Surveying

For areas not represented by One-Call Systems International, contact the appropriate utility companies to locate and mark the underground installations. Do not rely on visual evidence of underground utilities such as manhole covers or electrical drop boxes...**CALL!**

## WORK SITE ASSESSMENT

Examine the work area for any conditions or obstructions that may inhibit tilling or create a safety hazard for the operator or others. Use the information in this manual combined with good judgment to identify any hazards to avoid.

In addition to calling to DETERMINE LOCATION OF UNDERGROUND UTILITIES (see previous section for details), the operator and/or job foreman should visually inspect the work site. Look for electrical drop boxes, notices of underground placements, manhole covers, recent trenching or tilling activity, any evidence of possible underground placements, banks, drop-offs, rocks, wire, uneven terrain, any existing holes and toxic ground conditions.



Only operate tiller outdoors and avoid breathing engine exhaust and fumes.  
**WARNING:** Engine exhaust contains carbon monoxide gas that is toxic. Breathing it can cause unconsciousness and death. Do not operate tiller near any source of flammable dust or vapors.

## WORK SITE ASSESSMENT (continued)



**WARNING:** Sparks from the engine exhaust can cause an explosion or fire in a flammable or explosive atmosphere. Fuel fumes can catch fire or explode.

Allow adequate side and overhead clearances between tiller and any objects such as buildings, fences, and trees.

Adequate lighting is required, daylight or artificial, for safe operation of the tiller.

Keep others away. If the job site is near a road or pedestrian path, warn and divert both motorized traffic and pedestrians. As appropriate, erect barriers, use traffic flag personnel, signs, cones, and lighting devices to insure safety.



**WARNING:** Someone could step into the tilled area by accident. Walking near the edge of the tilled area could cause loss of balance and possibly cause someone to fall into the rotating tines. Contact with the rotating tines while in operation will cause serious injury or even death.

**MACHINE FUNCTION CHECK:** If the operator releases the VALVE LEVER, the rotating tines should stop. This is intended for your safety and must be maintained in good functional condition. Contact your dealer or the factory if anything on the tiller does not function properly.

## CONTACT WITH UNDERGROUND UTILITIES

After LOCATING UNDERGROUND UTILITIES and performing the WORK SITE ASSESSMENT, accidental tine contact with a buried utility might still occur. If it does, stop tilling and call 911 for help.

If you cut a wire or cable, assume that you do not know what kind it is. It may be electrical or any one of several communication lines: telephone, television, or fiber optic. In any case, do not touch it or even look at the ends of it. Stop tilling and call 911 for help. Do not till any more until the appropriate utility company has assessed the situation, taken appropriate action, and informed you that is safe to proceed.

If you strike a pipe, it could be gas, oil, petroleum, water or sewer. In any case, stop tilling, shut off the engine, and evacuate the area immediately. **Call 911 for help.**

**Electrical wires or cables:** If you think that you may have severed electrical wires, stop tilling and call 911 for help. Keep yourself and other people away from the area.



**DANGER:** An electric shock could kill you. Assume that any severed wire or cable is HOT with voltage and do not touch it!

**Gas lines:** If you think that you may have struck a gas line, shut off the engine and evacuate the area immediately. Call 911 for help.



**DANGER:** A gas explosion could kill you. Sparks will likely occur from the tines scraping the metal pipe. If gas leaks out an explosion could easily occur.

**Fiber optic cables:** If you think that you may have severed a fiber optic cable, do not touch or even look at the ends of it.



**WARNING:** Fiber optic cables convey laser light that can injure your eyesight. Call 911 for help.