

GOOSENECK PUNCHES 88°

Other angles and radii are available upon request.

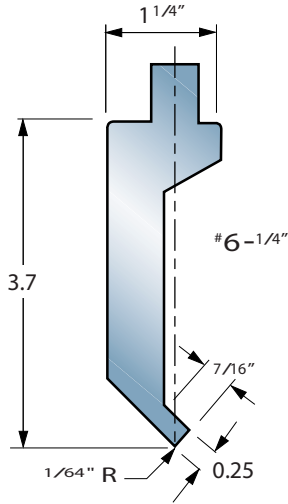

22 GA

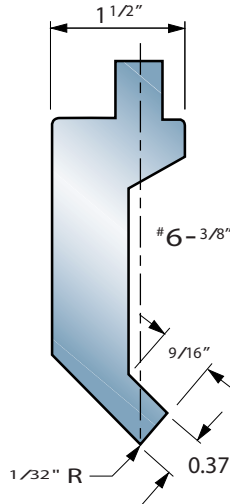

18 GA

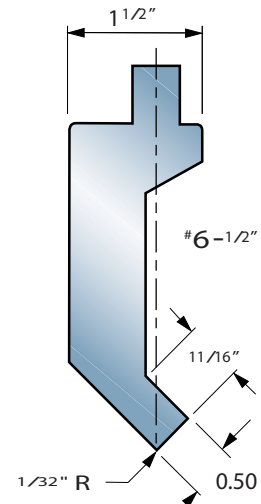

14 GA

PLEASE NOTE:

The size of the opening in the lower Die determines the inside radius of the bend. The recommended opening is eight times the material thickness and this will provide an inside radius equal to approximately 15% of the Die opening. This is generally just short of the fracture point of most materials. By increasing the size of the Die opening, the pressure required to make the bend is considerably reduced while the inside radius is proportionately increased.

NOTE: Outside widths shown are Bar Sizes prior to cleanup.

Material gauges & material thickness shown at the bottom of the tools reflect recommended material capacity.

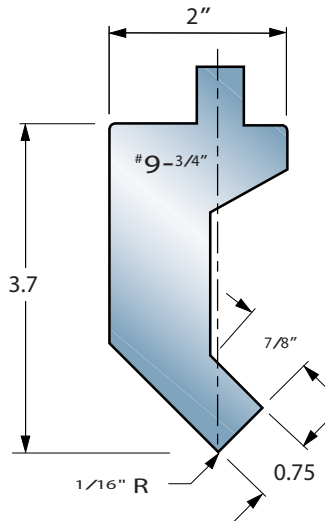

10 GA

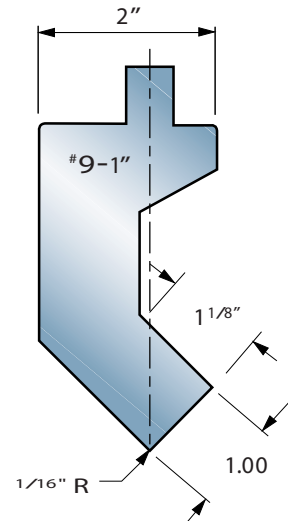

9 GA

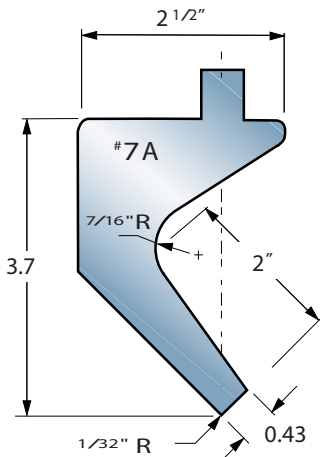

16 GA

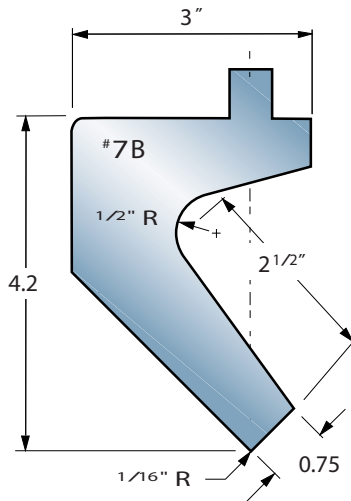

12 GA

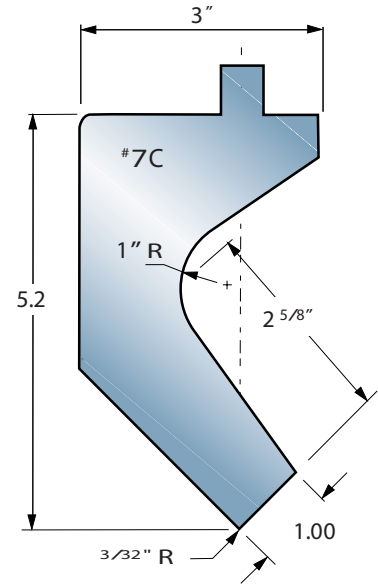

10 GA

GOOSENECK PUNCHES

Other angles and radii are available upon request.

