

CEILING APPROACHES - 2'x2'/600mm

Models:	TF-C VAV cooling only	TF-D Manually adjustable blades	TB-D Manually adjustable diffuser
	TF-CW VAV cooling and warm up heating	TF-RA Return air	ST-C VAV Cooling only
	TF-HC VAV cooling and VAV heating	TB-C VAV cooling only	ST-HC VAV Cooling and VAV Heating
		TB-CW VAV cooling and warm up heating	EF DDC Interoperable

TABLE OF CONTENTS	
General	1
Hard (Plaster) Ceilings	1
16" \times Joists	2
24" \times Joists	2
Dropped Lights	3
Concealed Spline Ceilings	3
Reveal Edge (Tegular) Ties	4
Box Type T-Bars	5
20" \times T-Bars	5
Metal Pan	6
Installation Below Ceiling	6

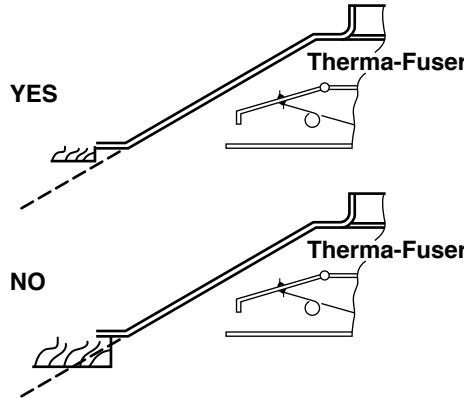

DIMENSIONS

Inlet Designation	OD	
	Inches $\pm 1/16$	mm ± 3
6	5 ¹⁵ / ₁₆	150
8	7 ¹⁵ / ₁₆	200
10	9 ¹⁵ / ₁₆	250
12	11 ¹⁵ / ₁₆	300

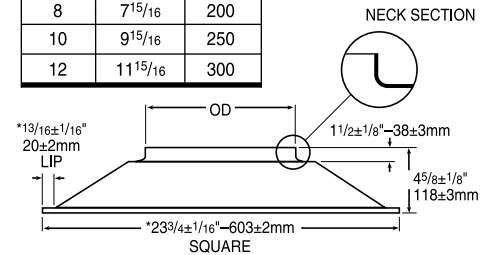

*595±2mm Square with 12±2mm lip available
 —specify 595mm square.

GENERAL

The rule of thumb when installing Therma-Fuser diffusers in special ceilings is that obstacles should not go below the plane of the diffuser casing extended. Breaking this plane reduces the throw and destroys throw completely

at low air flows. Small inconsistencies above the plane of the casing extended have little effect on Coanda or throw.

Models TF, TB, ST and EF Therma-Fuser diffusers are suitable for lay in 2 foot grid ceilings. Dimensions are as shown:

These Therma-Fuser diffusers can be used with other ceiling approaches as shown in this brochure.

TF, TB, ST and EF Therma-Fuser diffusers also are available for metric 600 mm x 600 mm grid ceilings. The -595 option is 595 mm square with a lip of 12mm.

Hard (Plaster) Ceilings

Alternatives for installation of Therma-Fuser units in hard ceilings and other ceilings where lay in is not practical but where a 2 foot square opening is available are:

1. T-Bar Frame. A field constructed frame of T-Bar converts a hard ceiling to a lay in eliminating the need for an access door for system adjustment and maintenance. Connect flex duct either by dropping the duct down before laying in the Therma-Fuser diffuser or by laying the Therma-Fuser diffuser above the ceiling next to the opening.

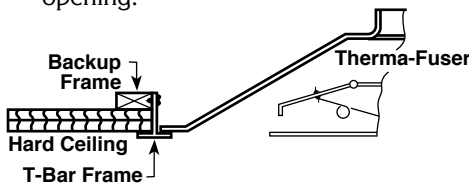

2. T-Bar Frame taped, covered with joint compound and sanded. This variation of #1 is an exceptionally attractive installation suitable for lobbies and other areas of high visibility.
3. Screw to Ceiling. This is a good solution for a hard duct connection, but requires a carefully cut ceiling opening. Drill a hole in the center of the Therma-Fuser diffuser lip on each of four sides taking care not to scratch the paint. Dimensions of the ceiling opening should be 22¹/₂" \pm 1/8" square. Use white precoated screws.

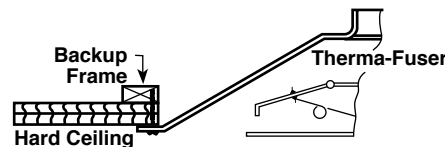

4. Hang in Ceiling. This requires a carefully cut ceiling opening and access

above the ceiling to tighten the hangers. See the -H option on the price sheet for the cost of security hanger brackets. The ceiling opening should be 22⁷/₈" \pm 3/8" square.

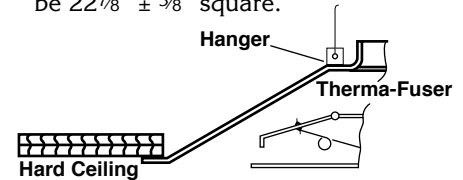

5. Acutherm Frame. The Acutherm frame is a factory made version of #1 painted to match the Therma-Fuser diffuser.

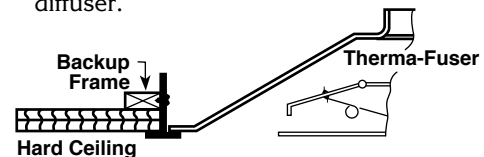

Hard (Plaster) Ceilings

—Continued

The frame has an extra large lip to cover irregularly cut ceiling openings. See drawing for dimensions. Ceiling supports are not supplied due to varying ceiling thicknesses. A furring strip (as shown) or metal angles can be used to secure the frame. It also can be hung. Dimensions of the ceiling opening should be not smaller than 24" square and no larger than 24½" square.

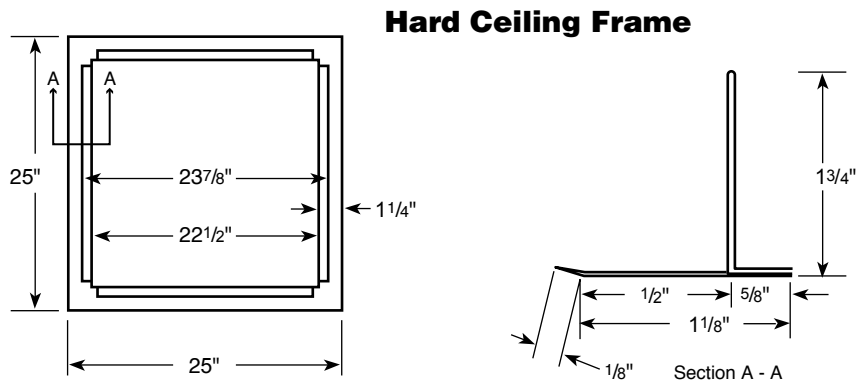

16" ⌘ Joists

Alternatives for installation in hard ceilings with 16" ⌘ joists are:

1. Frame out an opening 24" x 24" and use the Acutherm hard ceiling frame.

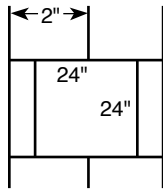

Assembly—Therma-Fuser and Drop box

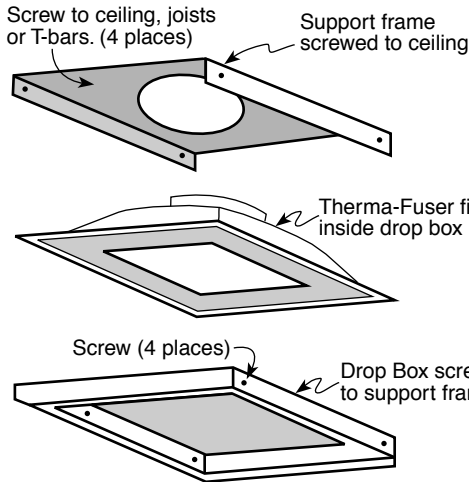

2. Use the Acutherm 4" drop box. Screw drop box support frame to joists and assemble as shown.

Note: Air from the Therma-Fuser diffuser 4" below the ceiling will jump back to the ceiling for a good Coanda effect.

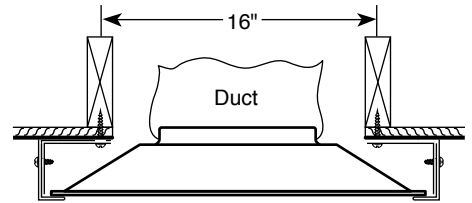

4" Drop Box Support Frame

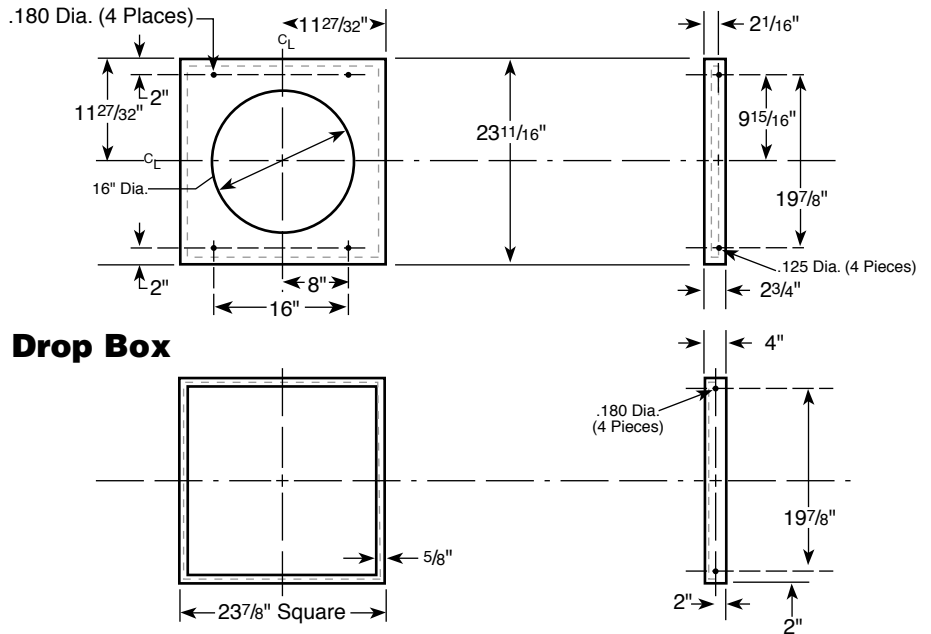

4" Drop Box

24" ⌘ Joists

Alternatives for installation in hard ceilings with 24" ⌘ joists are:

1. Frame out an opening 24" x 24" and use the Acutherm hard ceiling frame.

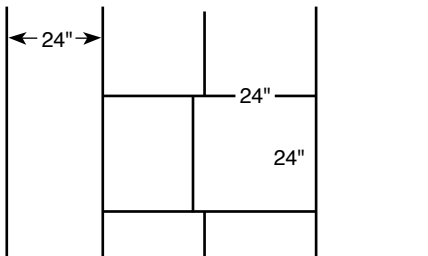

2. Either level or cut back ceiling material by 3/16" on each side to obtain a 22 3/8" x 22 3/8" opening and screw the Therma-Fuser diffuser to the joists. Drill two holes in each Therma-Fuser diffuser lip on two opposite sides taking care not to scratch the paint. Use white pre-coated screws.

Metal furring channel

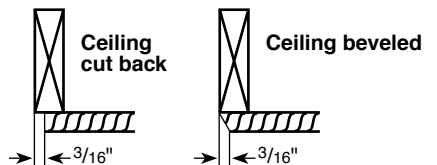
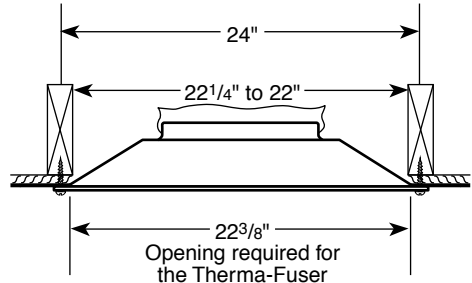
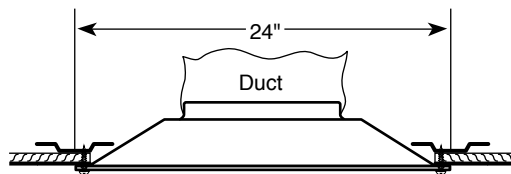

24" E Joists (Continued)

- Cut away a portion of the metal furring channel to make a 24" x 24" opening. Use the Acutherm hard ceiling frame. Install frame by attaching back-up angles (provided by others).

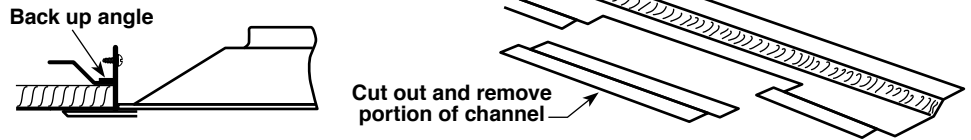

- Use the Acutherm 1 7/16" drop box. Screw drop box support frame to joists and assemble as shown in the assembly drawing for the 16" E joists drop box.

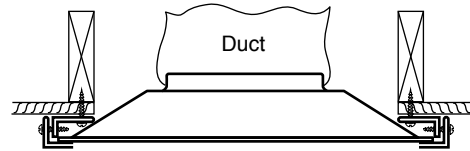

1 7/16" Drop Box Support Frame

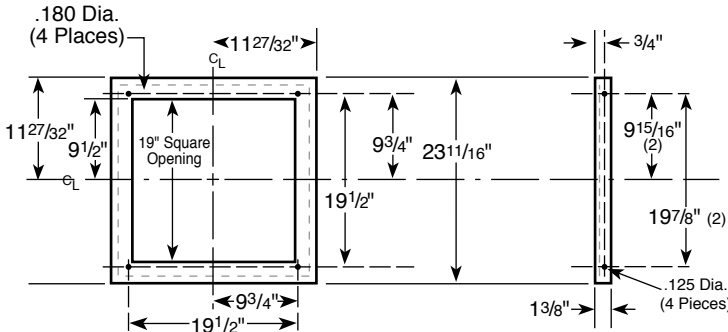

1 7/16" Drop Box

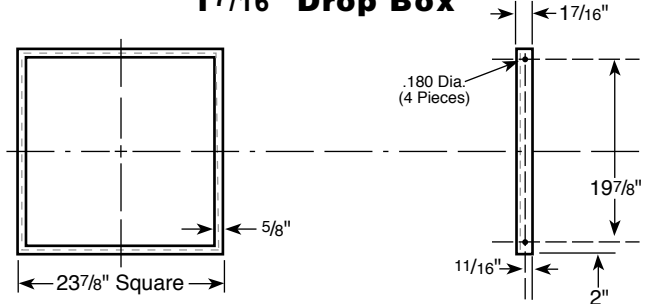

Dropped Lights

Installation of a Therma-Fuser diffuser next to a dropped light or other projection from the ceiling may cause supply air to bounce back and upset entrainment and the temperature of the secondary air sensed by the Therma-Fuser thermostat. Alternatives to avoid this are:

- Convert the Therma-Fuser diffuser to a three-way blow pattern away from

the light. See the Installation, Balancing and Maintenance Manual for each model diffuser for details.

- Use a drop box as low or lower than the light. See 16" E joists and 24" E joists for details of drop boxes.

Note: Air from a Therma-Fuser diffuser mounted in a 4" drop box next

to and in the same plane as the light will jump back to the ceiling for a Coanda effect after passing over the light.

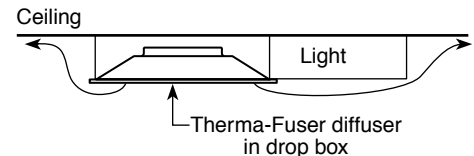

Concealed Spine Ceilings

The rule of thumb that obstacles should not go below the plane of the diffuser casing extended also allows the following alternatives.

- Lay On the Spine. Converts spine ceiling to a lay in eliminating the need for an access door for system adjustment and maintenance. Connect flex duct either by dropping the duct down before laying in the Therma-Fuser diffuser or by laying the Therma-Fuser diffuser above the ceiling next to the opening. Note: The appearance panel is not in the plane of the ceiling and ceiling tile raw edges may show.

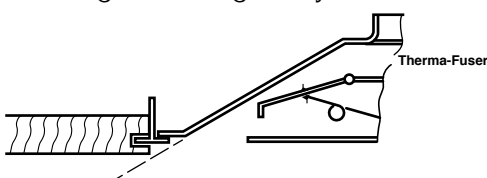

- Use Vinyl Trim Moldings. Also converts spine ceiling to a lay in, but covers the raw edges of the ceiling tile.

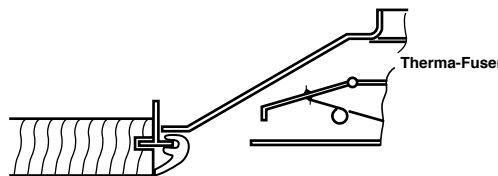

One source of vinyl trim molding is Chicago Metallic Corporation. For the location of their nearest distributor, see their web site at www.chicagometallic.com. The Chicago Metallic part no. for 2' moldings with mitered ends in white finish is 62-01.

- Use Acutherm Frame. Attach to T-bar spline using spring clips on the frame. Push frame up into ceiling opening. The spring clips will spring out when they are above the T-bar to lock frame in place. See drawing for dimensions.

The Therma-Fuser diffuser unit slides into the frame from either end and then drops down. Care should be

taken not to scratch the appearance panel. Otherwise, remove the appearance panel before sliding into frame.

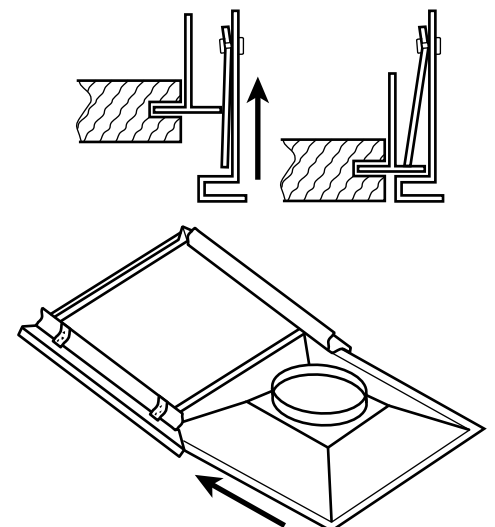

Concealed Spline Ceilings (Continued)

Two alternatives for installation are:

- Install frame in ceiling before sliding the Therma-Fuser unit into it. A 4 tile open area must be at the end of the frame so that it can be used when sliding the Therma-Fuser unit in and to connect the duct.
- Slide the Therma-Fuser unit into the frame first and then install them together in the ceiling as a unit. If the duct is not connected before installing, a 4 tile open area at the end or side is necessary to connect the duct.

Spline Ceiling Frame

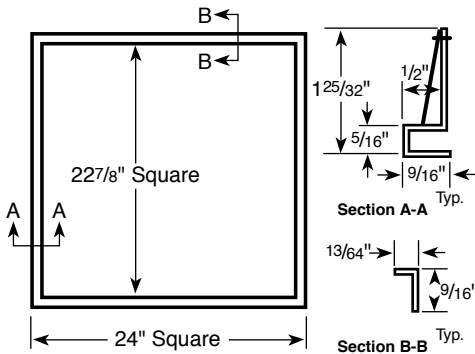

- For ceilings supported by inverted channel main runners on 24" Φ , trim or shear the Therma-Fuser diffuser and use Acutherm hard ceiling frame. Some concealed spline ceilings are hung from inverted channel main runners. If these runners are on 24" Φ , remove 4 tiles, remove adjacent cross T's and attach the hard ceiling frame to the main runners with screws. The Therma-Fuser diffuser lays in the hard ceiling frame and provides access above the ceiling without removing tiles.

For short main runner cross-sections, trim the top of the frame support leg to suit on two opposite sides. Wide main runners require a trimmed or sheared Therma-Fuser diffuser on two opposite sides so that it will clear the main runners when laying it in.

Examples:

Main Runner	Trim Frame Support Leg	Trim Therma-Fuser To Width Of
Armstrong ATS 7/8"	Remove 1/2"	} 23 3/8" Remove 3/16" from two opposite sides
Armstrong ATS 1 1/8"	Not Required	

Reveal Edge (Tegular) Tiles

Applying the rule of thumb that obstacles should not break the plane of the Therma-Fuser casing extended, some alternatives for reveal edge tiles are:

- Lay the Therma-Fuser diffuser on the T-bar. Unless the ceiling tile is very deep, this will not break the plane of the casing extended and it is easy to install. However, the Therma-Fuser appearance panel is not in the same plane as the ceiling tiles and the edges of the tiles will catch the air and become dirty quicker. For narrower 9/16" T-bars, check with the light fixture installers as they often have plastic clips which can help position the Therma-Fuser diffuser.

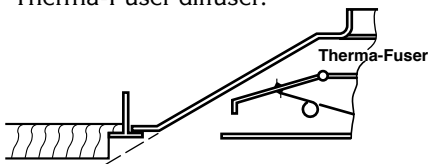

- Therma-Fuser diffuser with sheared casing and Acutherm frame.

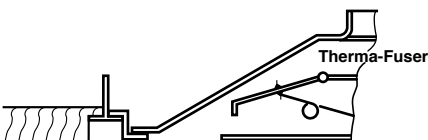

Two Acutherm frames are available: for 9/16" wide T-bar and for 1" wide T-bar. These frames can be stocked and the Therma-Fuser casing can be

sheared locally to fit. Otherwise, order sheared Therma-Fuser diffusers and frames from Acutherm.

A summary of frame and sheared width dimensions is:

Width T-Bar	Acutherm Frame				Shear Therma-Fuser Casing To Width Of:
	Designation	Width Of Frame Between T-Bars	Drop From T-Bar Ledge To Bottom Of Frame	Width Of Lip On Top Of Frame	
9/16"	T1	23 5/16"	11/32"	1/4"	23 3/16"
1"	T2	22 7/8"	13/32"	15/32"	22 3/4"

Tegular Ceiling Frame

Designation	T1	T2
Description	Reveal edge/ 9/16" T-Bar & Donn Finline	Reveal edge 1" T-Bar
T-Bar Width	9/16"	1"
"A"	23 5/16"	22 7/8"
"B"	11/32"	13/32"

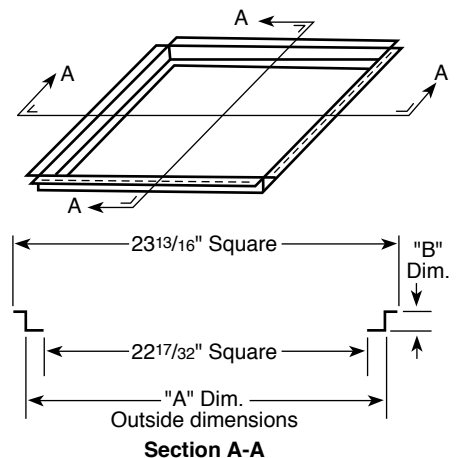

Box Type T-Bars

Some manufacturers of box type T-bars are: USG Donn® Finline and Armstrong Silhouette® Bolt-Slot.

Alternatives for box type T-bars are:

1. Lay the Therma-Fuser diffuser on the T-bar only if it does not break the plane of the casing extended. The Therma-Fuser diffuser will not be in the same plane as the ceiling tiles and the edges will catch the air and become dirty quicker. Do not lay the Therma-Fuser diffuser on T-bars with large cross-sections which break the plane of the casing extended.

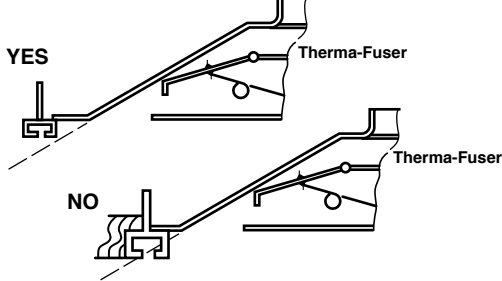

Note: Therma-Fuser diffusers can often be laid on box type without breaking the plane of the casing extended.

2. Use adaptor from ceiling manufacturer and sheared casing. Note that the adaptor must not break the plane of the casing extended. When ordering, specify outside dimensions of Therma-Fuser casing.

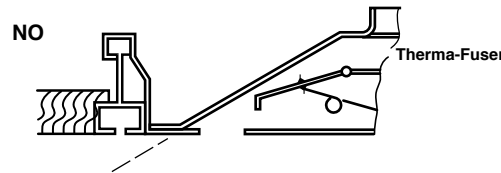
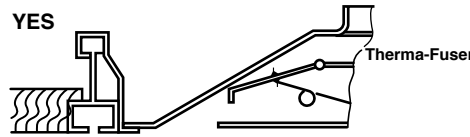

3. Screw standard Therma-Fuser diffuser to bottom of T-bars.

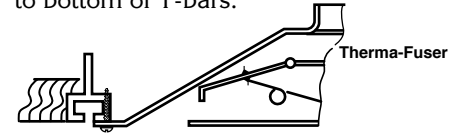

4. Sheared casing with reveal edge frame. See Reveal Edge Tiles for description of Acutherm frames.

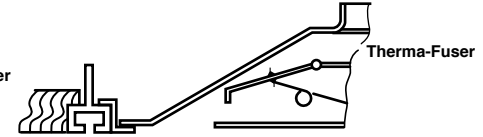

Note: Use a sheared Therma-Fuser diffuser and the Acutherm T1 frame (9/16" T-bar) for Donn ceilings.

20" ⌘ T-bars

Alternatives for installation in ceilings with 20" ⌘ T-bars (usually 5' grid) are:

1. Use Acutherm—1⁷/₁₆ drop box. Screw or rivet drop box support frame to T-bars. See 24" ⌘ joists for details.

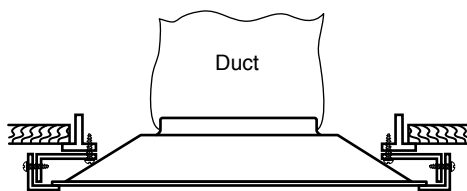

2. Arrange for 24" x 24" ⌘ T-bar opening in the ceiling.

To arrange for a 24" x 24" T-bar ⌘ opening in a ceiling with three 60" x 20" panels in a 5' x 5' supporting module:

- a. Trim two 60" x 20" panels to 60" x 18"
- b. Cut remaining 60" x 20" panel into two 24" x 18" pieces.
- c. Add two 24" T-bars and arrange as shown.

Perspective

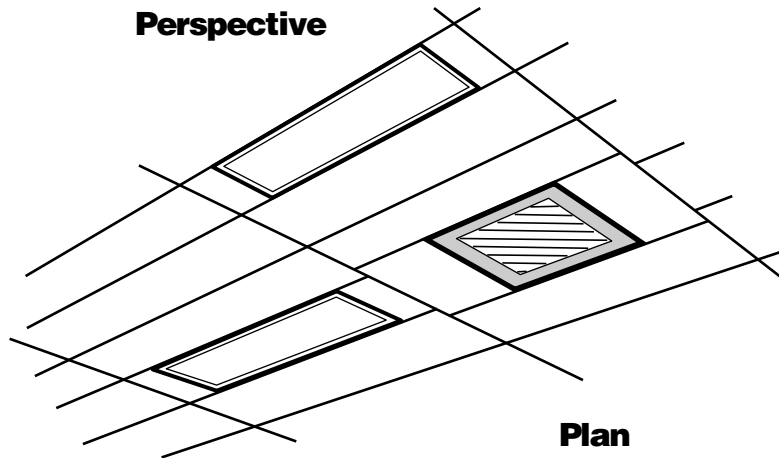

Plan

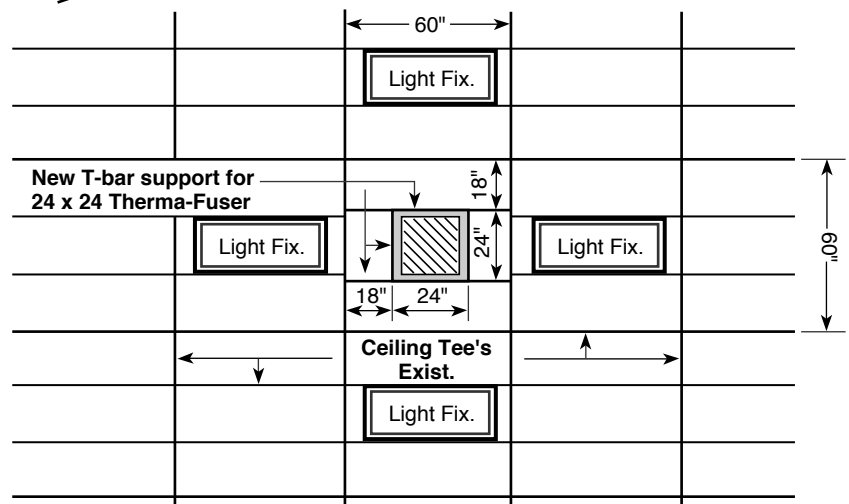

Metal Pan Ceiling

Use an Acutherm frame for metal pan ceilings. The Therma-Fuser unit lays in the frame. It is a 24" square frame with clips on two sides to fit the ceiling supports, see sketch.

